

# OWNER'S MANUAL

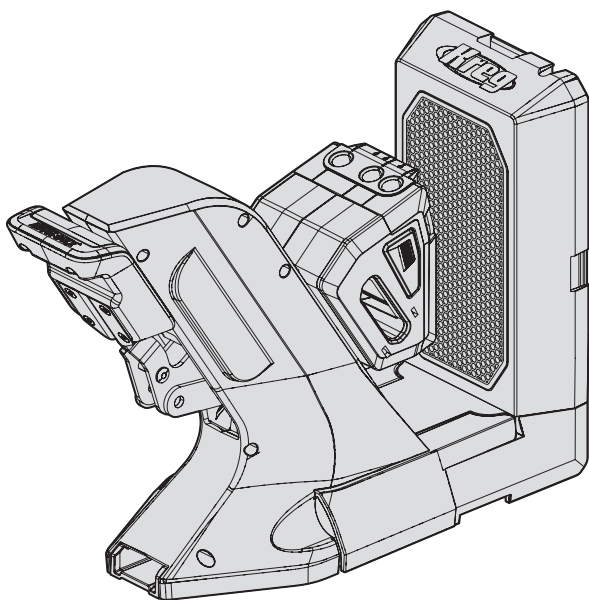

## Kreg Pocket-Hole Jig 700-Series

Manual applies to all 700-Series Pocket-Hole Jigs



**WARNING** Every user must read and follow instructions and safety precautions in this manual. Failure to do so could result in serious injury. Save manual for future reference.

### We're here to help.

We want you to have an exceptional project building experience.

If you have questions or need support, please get in touch.

1-800-447-8638 | [technicalsupport@kregtool.com](mailto:technicalsupport@kregtool.com)

### Tell us about your experience.

Your opinion counts. And we're always looking for ways to improve.

Share your feedback so we can keep growing and innovating for you.

[www.kregtool.com/feedback](http://www.kregtool.com/feedback)

English	2
French (N. America)	23
Spanish (N. America)	45
French	67
Spanish	89
German	111

# Table of Contents

Safety Precautions . . . . .	2	Using Your Kreg Jig . . . . .	18
Pre-Assembly . . . . .	3	Removing the Jig from the Docking Station . . . . .	19
Product Description . . . . .	3	Removing a Kreg 700-Series Jig from a Mounted Docking Station . . . . .	19
Onboard Tool Storage . . . . .	4	Removing a Kreg 700-Series Jig from an Unmounted Docking Station . . . . .	20
Adjustable Clamp Pressure . . . . .	4	Maintenance . . . . .	21
Extension Wings . . . . .	5	Care and Cleaning . . . . .	21
Mounting Option . . . . .	5	Accessories . . . . .	21
Dust Collection Accessories . . . . .	6		
Docking Station Assembly . . . . .	7		
Operation - Drilling Pocket Holes . . . . .	12		
Operation - Drilling and Driving Pocket-Hole Screws . . . . .	17		

## Safety Precautions

**WARNING** Before using a power tool with this product, read and follow the tool manufacturer's instructions and safety precautions in addition to the safety precautions below to reduce the risk of serious injury from hazards such as fire, electric shock, or rotating drill bit.

- Always wear personal protective equipment recommended by the manufacturer of the power tool you are using, such as eye, hearing, or respiratory protection.
- The drill bit is sharp. Handle with care.
- Do not allow familiarity gained from frequent use of your tools to replace safe work practices. A moment of carelessness is sufficient to cause serious injury.
- Avoid awkward hand positions where a sudden slip could cause contact with the rotating bit.
- When drilling, always ensure that the workpiece is clamped securely. It is dangerous to hold the workpiece in place by hand.

**WARNING** Do not operate this tool or any machinery while under the influence of drugs, alcohol, or medications.

**WARNING** This product can expose you to chemicals including Acrylonitrile and other chemicals, which are known to the State of California to cause cancer and reproductive harm. For more information go to [www.P65Warnings.ca.gov](http://www.P65Warnings.ca.gov).

# Pre-Assembly

Review this section before you begin. Ensure that you have all tools and materials on hand. Compare the package with the items listed in the Product Description section. If any item is missing or lost, do not use this product. Contact Technical Support or return the product to the place of purchase.

## Product Description

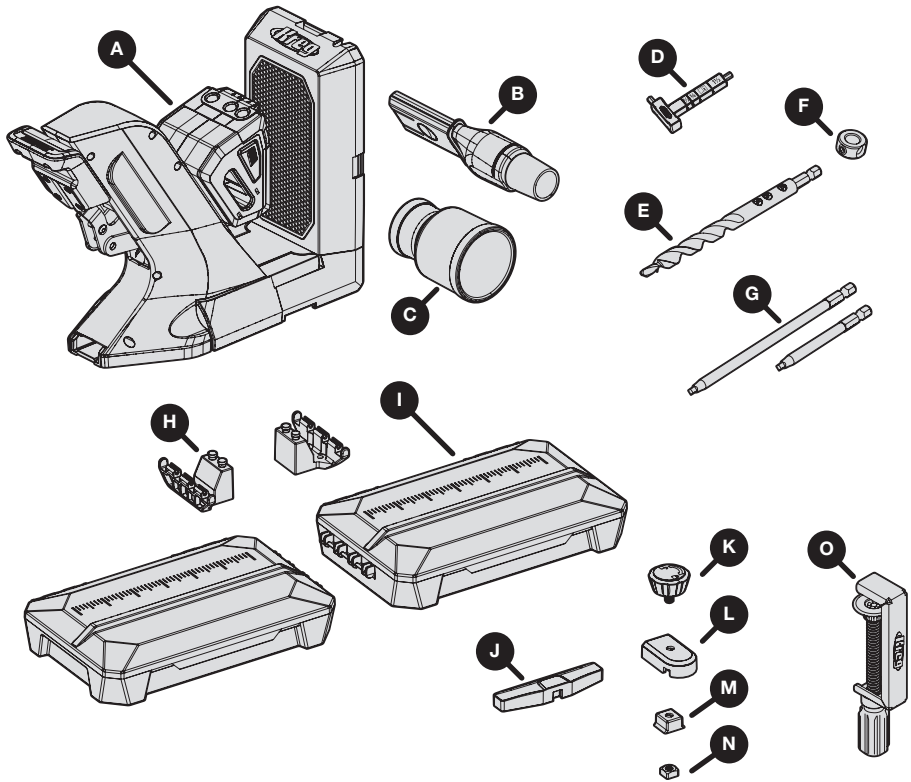

Part	Description
A	KPHJ720 Jig
B	Dust collection blade
C	Dust adapter
D	Material thickness gauge/Hex wrench
E	Easy-set pocket-hole drill bit
F	Easy-set stop collar
G	Driver bits (3" and 6")

Part	Description
H <sup>1</sup>	Dock adapters for KPHJ720 (2)
I <sup>1</sup>	Material support wings (2)
J <sup>1</sup>	Adjustable stop arm
K <sup>1</sup>	Adjustable stop knob
L <sup>1</sup>	Adjustable stop base
M <sup>1</sup>	Adjustable stop base wedge
N <sup>1</sup>	Adjustable stop square nut
O <sup>1</sup>	KPHA760 Pocket-hole jig clamp

<sup>1</sup> These parts from the KPHA750 pocket-hole jig docking station are included with the KPHJ720PRO package.

**Note** The product also includes two sample screw packs (not shown).

## Onboard Tool Storage

The KPHJ720 Jig (A) provides onboard storage for these items:

- Easy-set pocket-hole drill bit (E) with easy-set stop collar (F) attached
- Material thickness gauge/hex wrench (D)
- 3" and 6" driver bits (G)

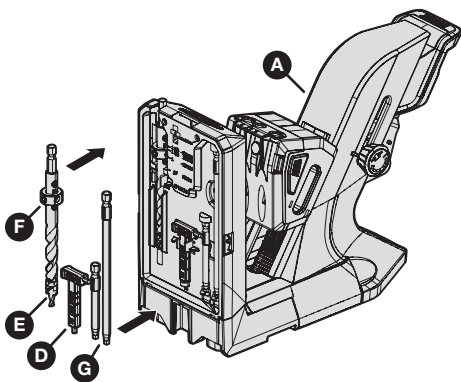

## Adjustable Clamp Pressure

A knob (1) on the side of the KPHJ720 Jig enables you to increase or decrease the clamp pressure that is applied to your workpiece. Five pressure settings are available. The jig ships from the factory with the clamp pressure at the middle setting.

### To adjust the clamp pressure:

- Lift the jig handle all the way up to release the clamp pressure.
- Rotate the clamp-pressure adjustment knob (1) one click in the desired direction:
  - Clockwise to decrease pressure
  - Counterclockwise to increase pressure
- With a test block in place, reapply the clamp pressure by pressing the jig handle down in one smooth motion until the jig handle is at its travel limit.
- Repeat this process as needed until you are satisfied with the clamp pressure.

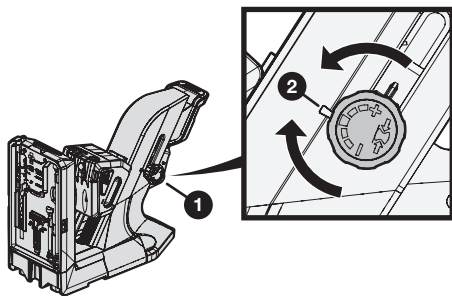

### Note

- The jig is set to minimum clamp pressure when the “minus” sign on the clamp-pressure adjustment knob (1) aligns with the selection mark (2).
- The jig is set to maximum clamp pressure when the “plus” sign on the clamp pressure adjustment knob (1) aligns with the selection mark (2).

## Extension Wings

The KPHJ720 Jig has two extension wings, one (1) on each side of the jig base. You can rotate one or both wings out to 90 degrees to provide added stability and material support.

**Note** If you use the optional docking station with the jig, you will use the docking station's material support wings instead of the extension wings shown here. See **Docking Station Assembly** on page 7.

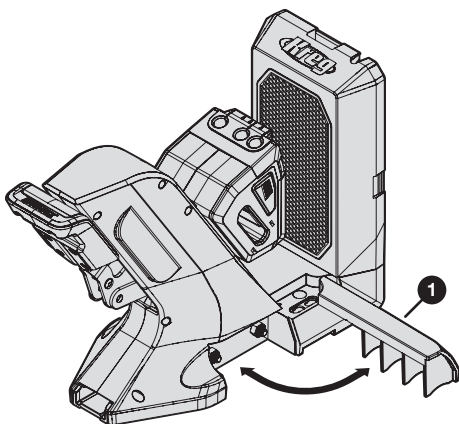

## Mounting Option

If desired, you can mount the KPHJ720 Jig to your work surface for added stability.

**Note** These instructions apply to a jig that is used *without* the optional docking station.

- Place the jig in the desired position on your workbench.
- Rotate the extension wing (1) on each side of the jig to 90 degrees.  
Two mounting holes (2) are now accessible (one hole on each side of the jig).
- Drive one Kreg pocket-hole screw (3) through each mounting hole (2).

**Note** You can use Kreg SML-C125 screws or any other Kreg pocket-hole screw.

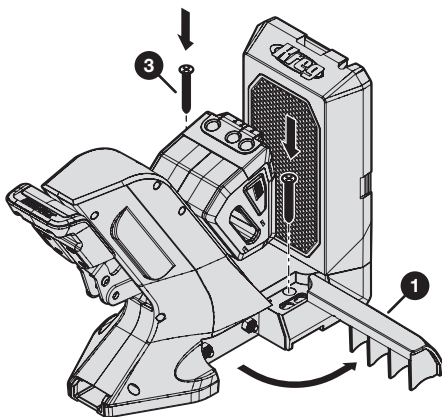
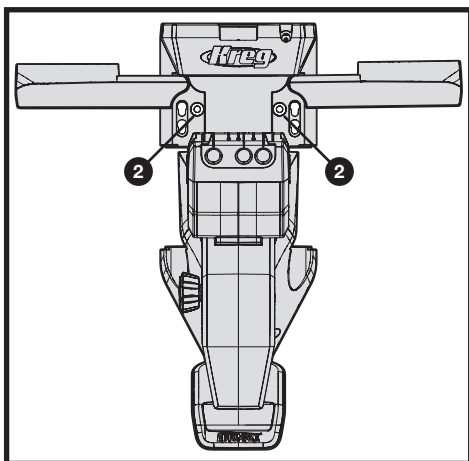

## Dust Collection Accessories

You can use the provided dust collection accessories to capture dust as you drill.

### To attach the dust collection accessories:

- If necessary for the hose diameter you are using, attach the dust adapter (C) to the wide end of the dust collection blade (B).

Hose diameter	Requires dust adapter?
1-1/4"	No
1-7/8"	No
2-1/2"	Yes

- Insert the narrow end of the dust collection blade (B) into the left or right side of the jig.

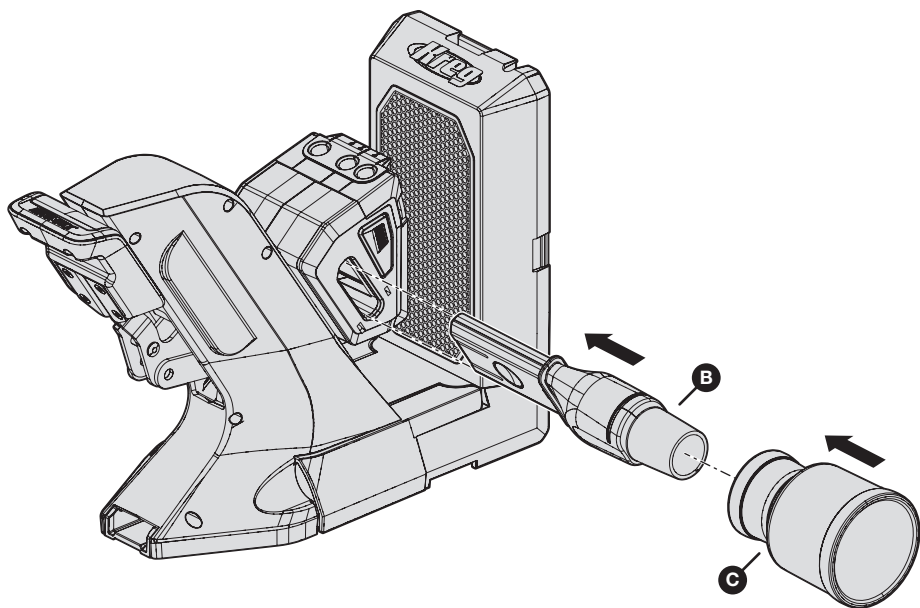

**Note** You can leave the dust collection blade and dust adapter attached to the jig when the jig is not in use.

# Docking Station Assembly

This section describes how to assemble the docking station that is included with the KPHJ720PRO package. You can also purchase the docking station separately (see **Accessories** on page 21).

**Note** If you are not using the docking station, skip this section and continue to **Operation - Drilling Pocket Holes** on page 12.

## 1 Connect the Dock Adapters to the Jig

- Place the KPHJ720 Jig (A) on a flat surface.
- With one hand, lift one side of the jig (A) slightly.
- With your other hand, place a dock adapter (H) under the jig (A) so that the attachment pins (1) fit into the corresponding hole on the underside of the jig (A); then slide the dock adapter (H) toward the jig handle (3) to lock the dock adapter (H) into position.

**Note** One side of a dock adapter (H) has attachment pins (1) that fit under the jig; the other side has a connector (2) for a material support wing (not shown). Ensure that the wing-connector side (2) of the dock adapter (H) extends out from the side of the jig (A).

- Repeat steps b and c to connect the other dock adapter (H) on the opposite side of the jig (A).

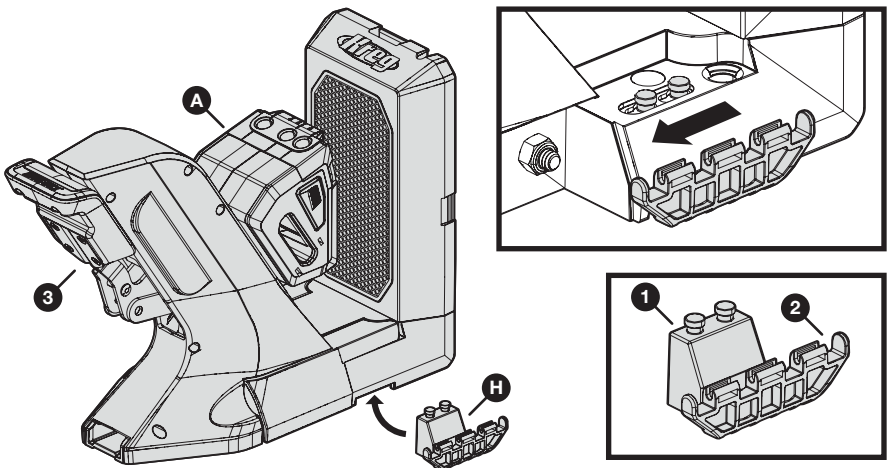

## 2 Connect the Material Support Wings to the Dock Adapters

**Tip** The material support wings also serve as storage boxes.

- Hold a material support wing (I) right-side up (so that the lid of the storage box is facing up and opens away from you).
- Align the connector (1) on the side of the material support wing (I) with the connector (2) on the dock adapter (H) that extends from the side of the jig (A); then press the material support wing (I) down firmly so that the connectors snap together.

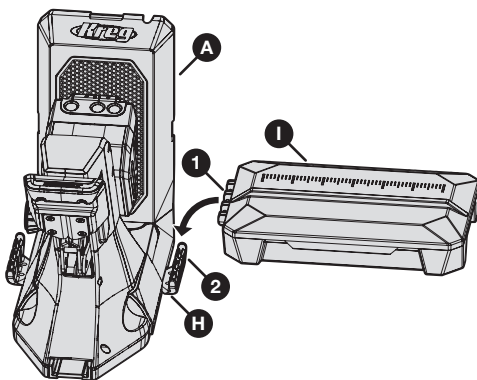

**Note** The bars on the material-support-wing connector (1) snap into the grooves on the dock-adapter connector (2).

- Repeat these steps to connect the other material support wing (I) to the dock adapter (H) on the opposite side of the jig (A).

**Note** You can fold the material support wings up to the vertical position to save space when the jig is not in use, or to make it easier to move the jig from one location to another. Always fold the material support wings down before using the jig.

**Note** If you use the dust collection accessories (page 6), you must remove them from the jig in order to fold the material support wings up.

### To fold up the material support wings:

- Fold the material support wing (I) up to a vertical position.
- Rotate the wing lock (1) inward until the latch (2) engages securely in the notch (3) on that side of the jig.

### To fold down the material support wings:

- Rotate the wing lock (1) outward until the latch (2) disengages from the notch (3) in the side of the jig.
- Fold the material support wing (I) down to the horizontal position.

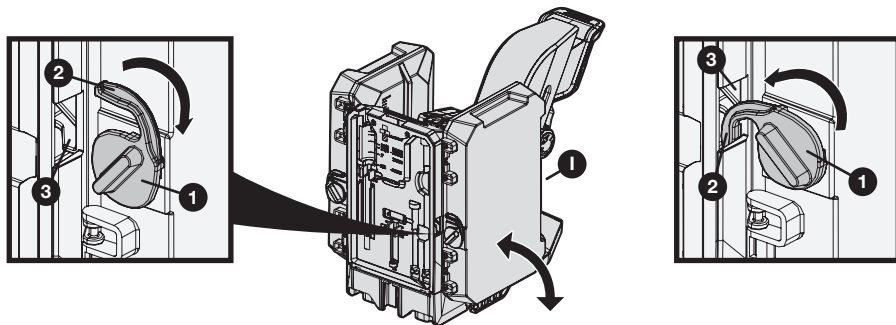



### 3 Optional: Mount the Dock Adapters to a Work Surface

If desired, you can mount the dock adapters to your work surface for added stability.

- Place the docking station (with the 700-Series Jig attached to it) in the desired position on your workbench.
- Drive one Kreg pocket-hole screw (1) through each of the four mounting holes (2) in the dock adapters (H).

**Note** You can use Kreg SML-C125 screws or any other Kreg pocket-hole screw.

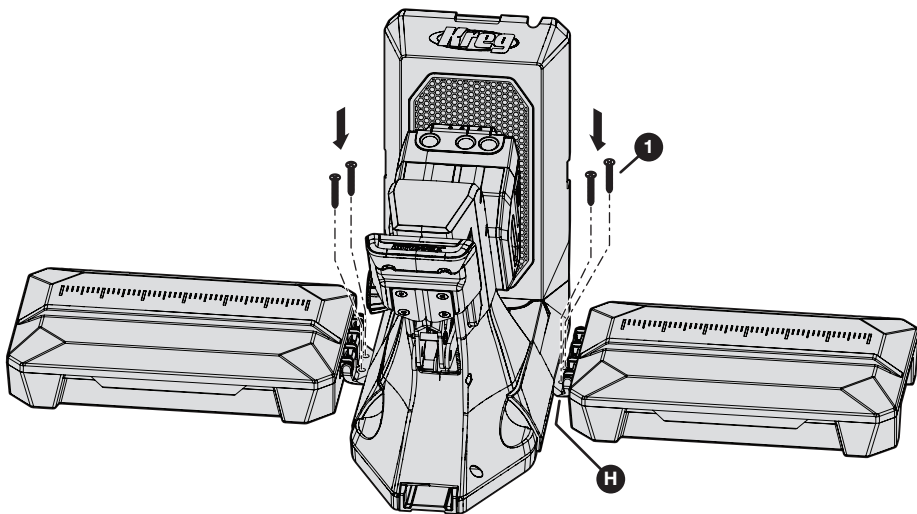
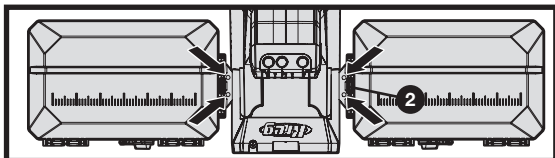

## 4 Assemble the Adjustable Stop Base

The docking station includes an adjustable stop that can be attached to either material support wing. The adjustable stop makes it easy to achieve repeatable results when you have many pieces that require the same pocket-hole spacing.

**Note** The adjustable stop has two parts: the adjustable stop base, which you will assemble in this step; and the adjustable stop arm, which can be attached to the adjustable stop base in different configurations (see step 5).

- Insert the screw (1) of the adjustable stop knob (K) into the hole on top of the stop base (L).
- Holding the knob (K) in position, turn the stop base (L) upside down so that the screw (1) extends upward.
- Drop the adjustable stop base wedge (M) onto the screw (1) with its flanged side facing up.

**Note** The adjustable stop base wedge (M) should sit flush with the adjustable stop base (L). If it does not sit flush, rotate the adjustable stop base wedge (M) 90 degrees.

- Place the adjustable stop square nut (N) onto the screw (1); then rotate the adjustable stop knob (K) until the adjustable stop square nut (N) is finger-tight.

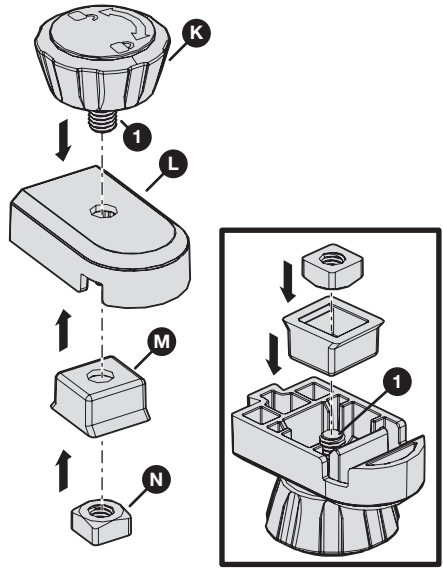

## 5 Attach the Adjustable Stop Arm to the Adjustable Stop Base

Slide a notch in the adjustable stop arm (J) down over the tab (1) on the adjustable stop base (L) until the adjustable stop arm (J) is fully seated on the tab (1).

**Note** The adjustable stop arm (J) has three notches: a center notch (2) on one side and two outer notches (3, 4) on the opposite side. Use the appropriate notch depending on how you want to configure the adjustable stop.

**Note** To change the configuration of the adjustable stop, lift the adjustable stop arm (J) off the adjustable stop base (L). Then slide a different notch of the adjustable stop arm (J) over the tab (1) on the adjustable stop base (L).

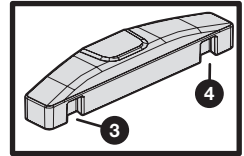
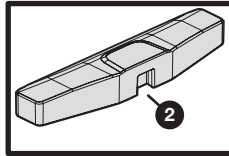
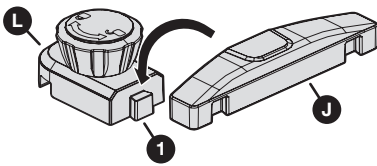

### Centered Configuration

Use the arm's center notch (2)

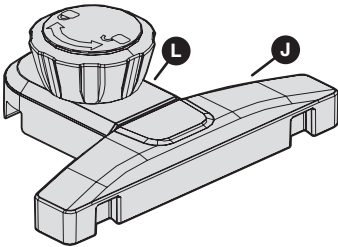

### Side Configuration

Use either of the arm's outer notches (3, 4), so that the arm (J) extends to one side of the base (L)

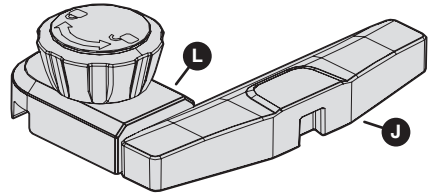

# Operation - Drilling Pocket Holes

## 1 Determine the Material Thickness and Set the Stop Collar

- Use the material thickness gauge (D) to determine the material thickness range.
- Set the stop collar (F) by placing it on the drill bit (E) and aligning the window of the stop collar (F) with the measurement thickness range determined in step a.
- Use the hex wrench built into the material thickness gauge (D) to lock the stop collar (F) into place on the drill bit (E).

**Note** If your material thickness falls in the  range, use the same setup techniques as the 3/4" range with a 1-1/2" screw.

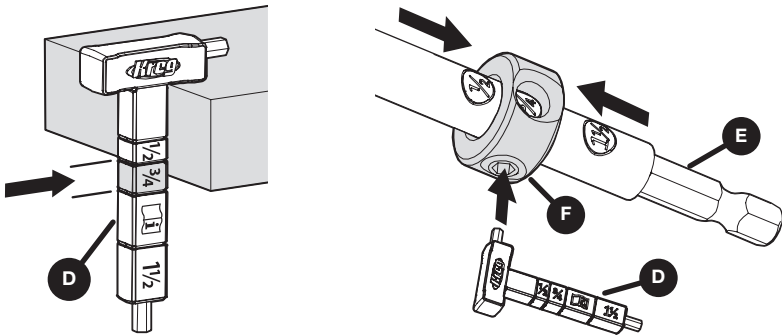

## 2 If applicable: Stabilize the Jig

- If you are using the docking station:** Fold both material support wings down to their horizontal position (1).
- If you are not using the docking station:** You can rotate one or both of the jig's extension wings (2) out from the jig base to provide additional stability, if desired.

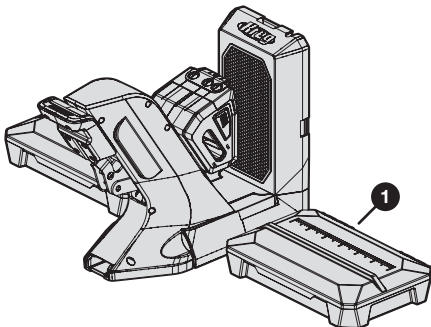

**With docking station:** Material support wings folded down

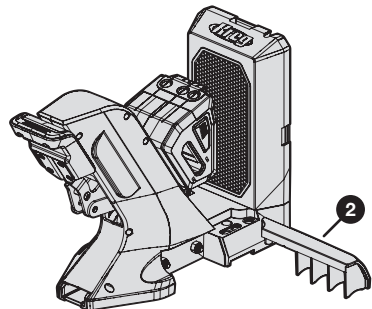

**Without docking station:** Extension wings rotated out

### 3 Position Your Workpiece

a. Place your workpiece in the jig and use the drill guide to align it.

**Note** There are two alternate methods for aligning your Kreg Jig with your workpiece:

- Align the center line of any pocket-hole guide (numbers 1, 2, or 3) with the desired location on your workpiece. For wider panels (over 3-1/2" wide) pocket holes should be placed 5/8" to 1-1/2" from each edge of the workpiece and then every 6" to 8".
- Use the board centering marks (letters A, B, or C) to center two pocket holes on the workpiece ranging in width from 1-1/4" to 3-1/2" wide. See the table below for details on each size range.

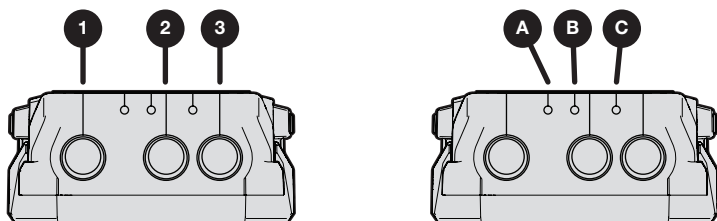

Board Width	Center Mark	Drill Guide
1-1/4" to 1-3/4"	C	2 and 3
1-3/4" to 2-3/8"	A	1 and 2
2-3/8" to 3-1/2"	B	1 and 3

b. When you are satisfied with the position of the workpiece in the jig, continue to step 4.

## 4 Clamp Your Workpiece

- a. Press down on the jig handle (1) in one smooth motion until the jig handle (1) is at its travel limit.

**Note** If you have difficulty pressing the jig handle (1) to its travel limit, decrease\* the clamp pressure.

- b. Check to see if your workpiece is held securely in the jig; increase\* the clamp pressure, if necessary.

**Note** Increase the clamp pressure if the clamp does not hold the workpiece as securely as you want, if you see movement in the workpiece, or if you are using a plug cutter drill guide attachment.

\* See **Adjustable Clamp Pressure** on page 4.

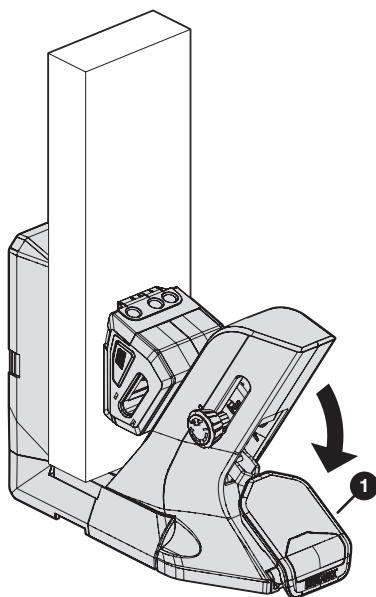

## 5 Optional: Set the Adjustable Stop

**Note** The adjustable stop enables you to drill pocket holes on similar workpieces at a faster pace. The adjustable stop is an accessory that is included with the docking station. If you are not using the docking station, skip this step and continue to step 6.

- a. If necessary, change the configuration of the adjustable stop to accommodate the size and orientation of your workpiece in the jig:
- **Wide workpiece:** If the workpiece is wide enough to extend onto the top of a material support wing (I), use the adjustable stop (1) in its *centered* configuration.
  - **Narrow workpiece:** If the workpiece does not extend across the gap between the jig and the material support wing (I), use the adjustable stop (1) in a *side* configuration.

**Note** For a side configuration, use whichever outer notch in the adjustable stop arm will be farther from the jig after you place the adjustable stop (1) onto a material support wing (I).

**Note** For instructions on changing the configuration, see **Attach the Adjustable Stop Arm to the Adjustable Stop Base** on page 11.

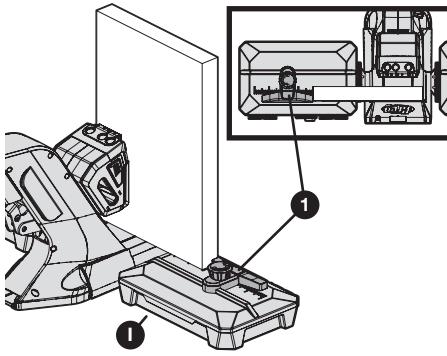

Adjustable stop (1) in centered configuration for wide workpiece

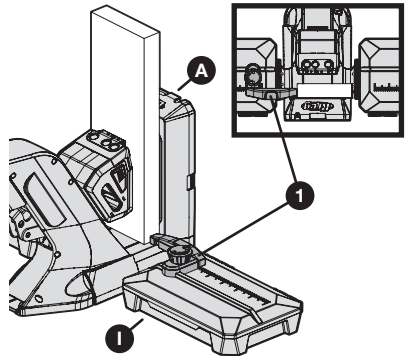

Adjustable stop (1) in side configuration for narrow workpiece

- b. Place the adjustable stop (1) onto the lid of a material support wing (l) so that:
- The edge of the adjustable-stop arm (J) rests snugly against the workpiece.
  - The notch (2) on the underside of the adjustable stop base fits over the rail (3) that runs across the lid of the material support wing (l).
- c. Rotate the adjustable stop knob (K) clockwise until tight to secure the adjustable stop (1) in position.

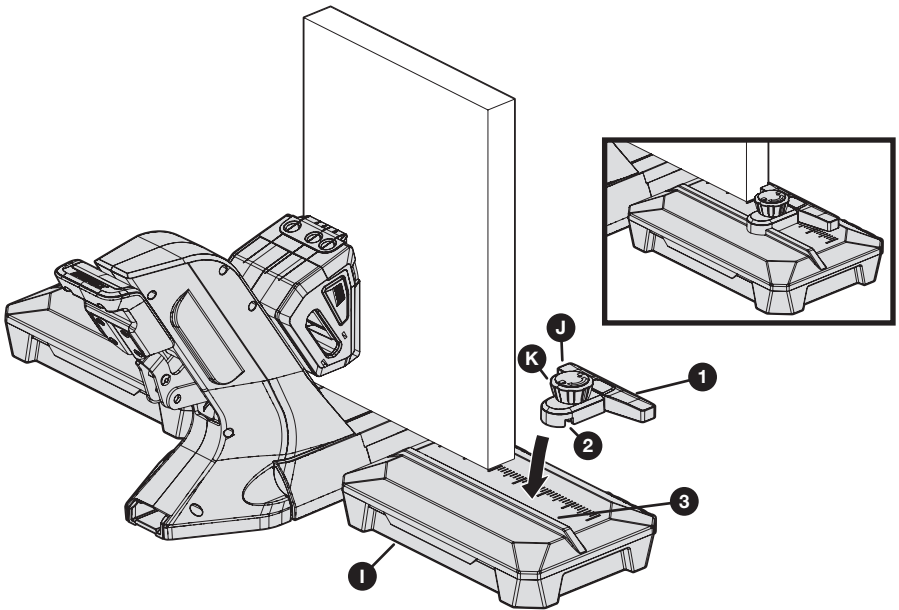

**Note** To reposition or remove the adjustable stop (1), rotate the adjustable stop knob (K) counterclockwise to loosen it. Then slide the adjustable stop (1) to a new position along the rail (3) or lift it off of the material support wing (l).

## 6 Drill Pocket Holes

**WARNING** When drilling, always ensure that the workpiece is clamped securely and that the jig handle is pressed down to its travel limit.

- Place your prepared drill bit (E) with stop collar (F) into your drill.
- Insert your drill bit (E) into the drill guide (1) and bring your drill up to speed before contacting the workpiece to ensure correct rotation of the drill bit.
- Drill until the stop collar (F) stops going any deeper due to contact between the stop collar (F) and drill guide (1). Remove the drill bit (E) from the drill guide (1) while the drill bit is still rotating.
- When you are finished drilling pocket hole(s), lift the jig handle to release the clamping pressure; then remove your workpiece.

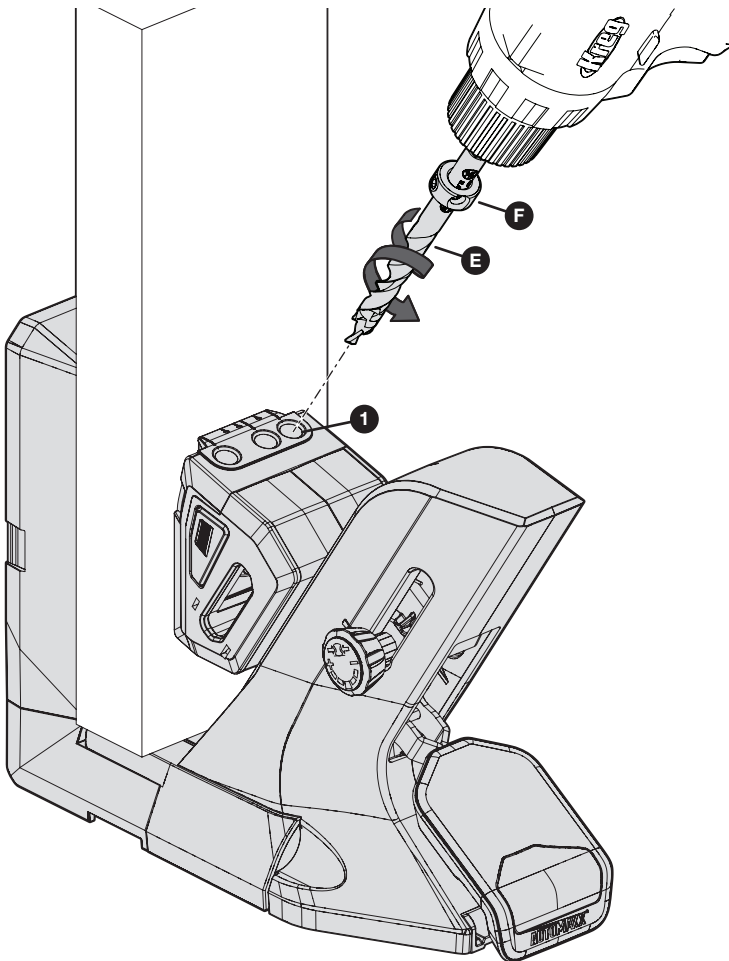





# Operation - Drilling and Driving Pocket-Hole Screws

For best results, follow these guidelines when drilling and driving pocket-hole screws:

- Use the correct screw size according to this chart:

Gauged Material Thickness	Easy-Set Stop Collar	Material Thickness Setting	Screw Length
1/2 Range	1/2	Automatic	1" (25 mm)*
3/4 Range	3/4		1-1/4" (32 mm)
 3/4	3/4		1-1/2" (38 mm)
1-1/2 Range	1 1/2		2-1/2" (64 mm)

\* A 1" screw is recommended for most applications, but if your workpiece is on the low end of the range, a 3/4" screw might be required to keep the screw tip from protruding.

**Note** If your material thickness falls in the  range, use the same setup techniques as the 3/4" range with a 1-1/2" screw. For more information on screw selections, go to [www.Kregtool.com/Screws](http://www.Kregtool.com/Screws) or simply scan the QR code on the side of your sample screw package.

- Clamp joints in place to ensure a better finished joint. These examples show face joints and edge joints.

**WARNING** When drilling, always ensure that the workpiece is clamped securely.

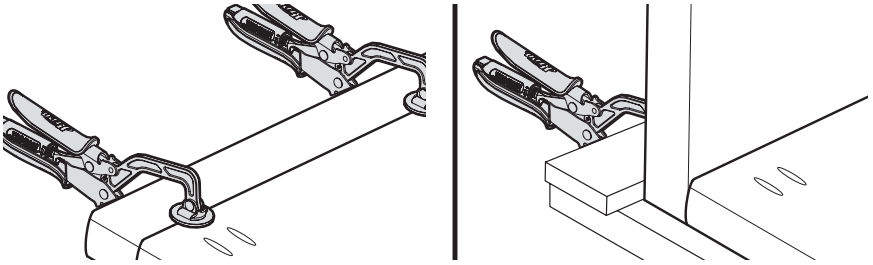

- Place your screw on the driver tip (E), position the screw in the pocket hole, and drive the screw until it is fully seated without overdriving.

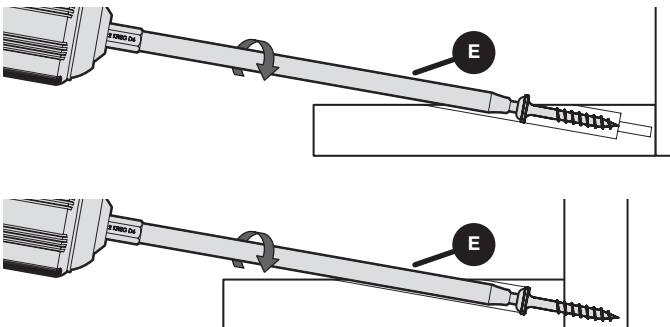

# Using Your Kreg Jig

Your Kreg Jig has been designed to work in either a vertical or horizontal orientation to accommodate your workpiece.

To switch from one orientation to the other, simply rotate the jig 90 degrees.

In either orientation, you can use the pocket-hole jig clamp (O) to secure the jig in place on your workbench.

Orientation	Description	Clamp Position Options
Vertical	Tool-storage side (1) is vertical	One available clamp position (2)
Horizontal	Tool-storage side (1) is face-down	Two available clamp positions (3, 4)

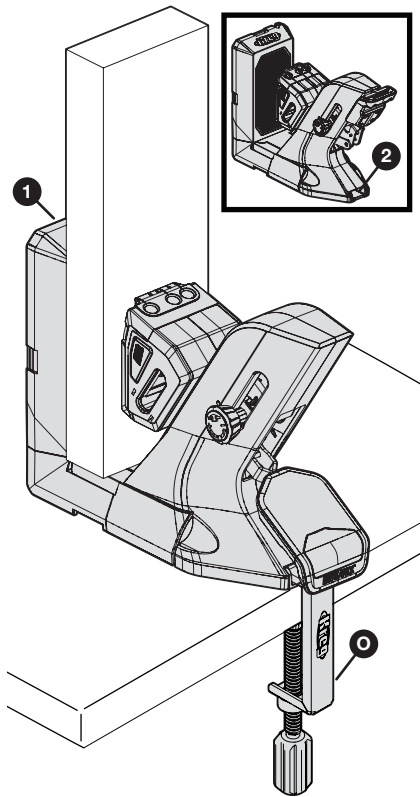

**Vertical**

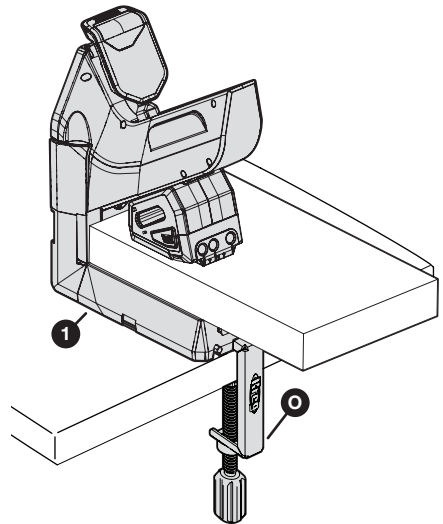
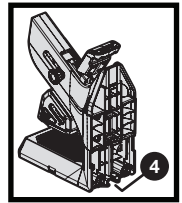
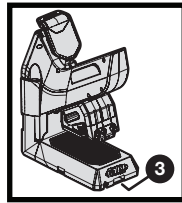

**Horizontal**

# Removing the Jig from the Docking Station

If you use the 700-Series Jig with the optional docking station, you can remove the jig from the docking station at any time.

## Removing a Kreg 700-Series Jig from a Mounted Docking Station

With the jig handle (1) facing you, slide the jig (A) toward you until the jig (A) disengages from the dock adapters (H). Then lift the jig (A) off the dock adapters (H).

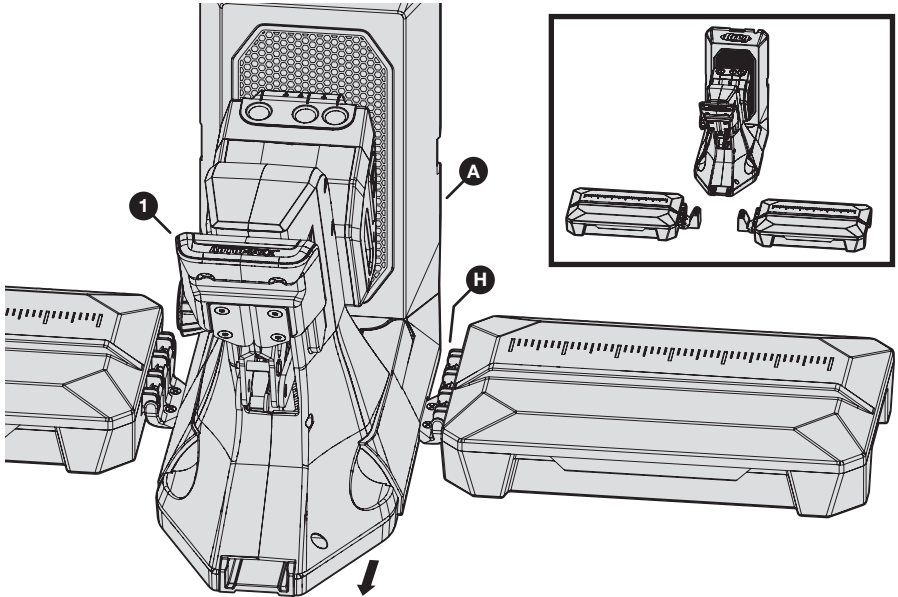

## Removing a Kreg 700-Series Jig from an Unmounted Docking Station

- a. Detach each material support wing (I):
  1. Grasp the material support wing (I) close to where it connects to the dock adapter (H).
  2. Gently lift up the material support wing (I) so that the material-support-wing connector (1) pops out of the dock-adapter connector (2).
- b. For the dock adapter (H) on each side of the jig (A):
  1. Lift that side of the jig (A) slightly off the work surface.
  2. With the jig handle (3) facing you, slide the dock adapter (H) away from you until the dock adapter (H) disengages from the slot on the underside of the jig (A).
  3. Pull the dock adapter (H) out from the underside of the jig (A).

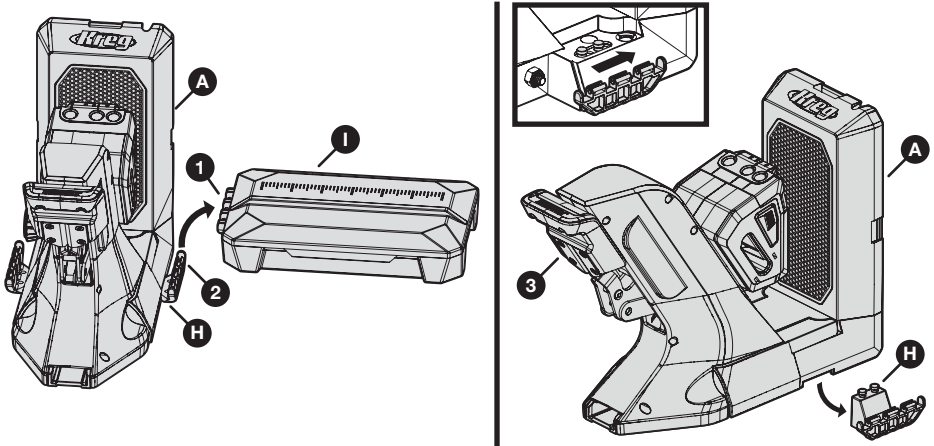

## Maintenance

Periodically apply light oil to the moving linkage of the handle.

## Care and Cleaning

Periodically clean your tool by vacuuming any chips and wood dust.

Use a damp cloth to wipe Sure-Grip™ anti-slip pad surfaces clean of dust and debris.

## Accessories

KPHA730 Kreg Micro Drill Guide

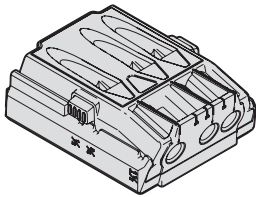

KPHA750 Pocket-Hole Jig Docking Station

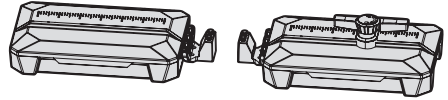

KPHA760 Kreg Bench Clamp

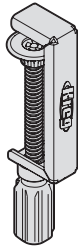

KPHA740 Plug Cutting Drill Guide

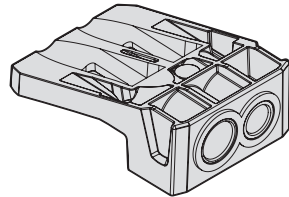



## **EXPLORE. BUILD. SHARE.**

We're makers just like you.

That's why we love to see what you're working on.

Share with the community and get inspired!

**#madewithKreg**

Get free plans, project resources, and more.

*[kregtool.com](http://kregtool.com) and [buildsomething.com](http://buildsomething.com)*