

Pro Series



OWNER'S MANUAL

GUIDE D'UTILISATION
MANUAL DEL PROPIETARIO

DK5100 Pneumatic Model

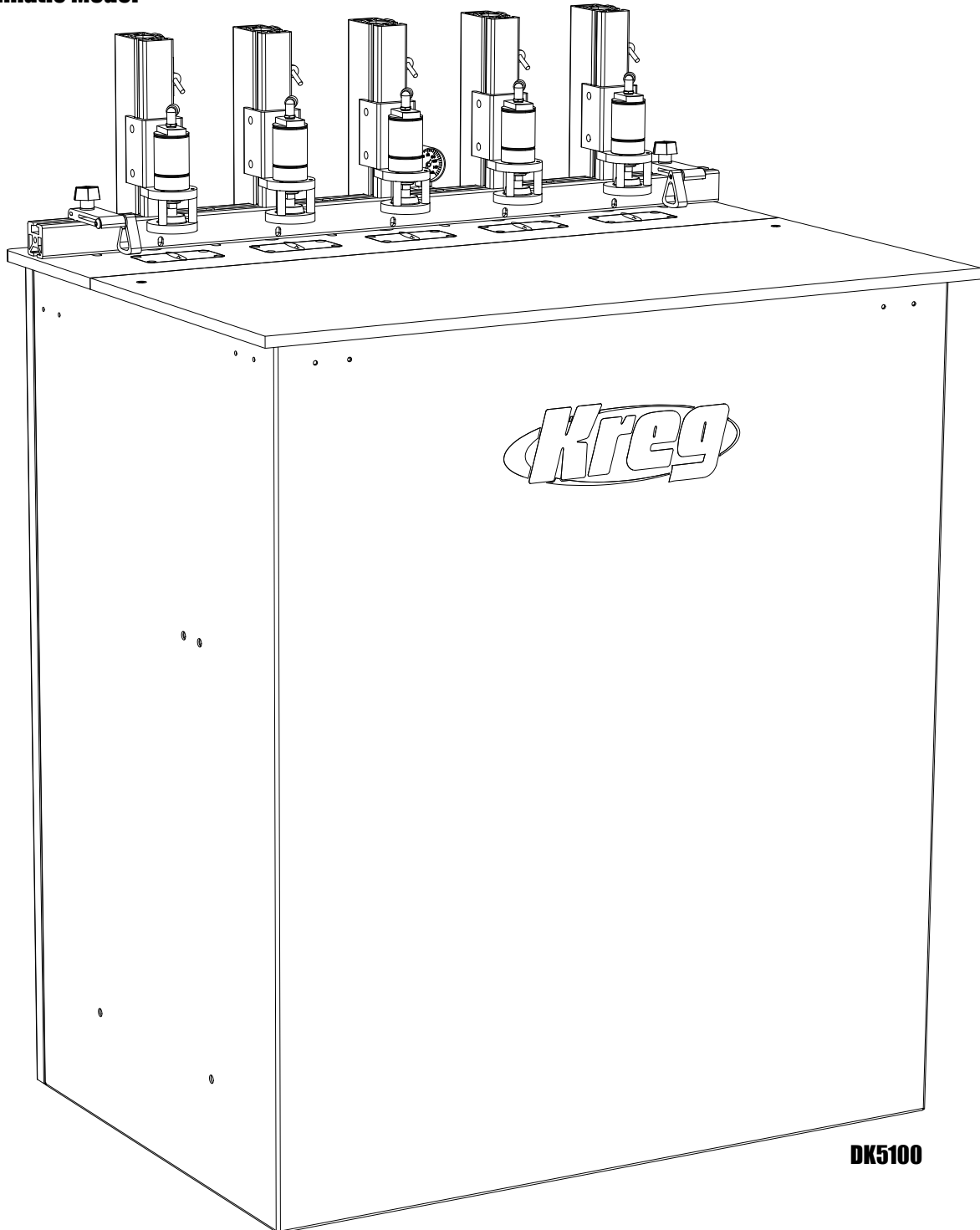

DK5100

GENERAL SAFETY INSTRUCTIONS

SAVE THESE INSTRUCTIONS

- 1) Work area safety
 - a) Keep work area clean and well lit. Cluttered or dark areas invite accidents.
 - b) Don't use power tools in a dangerous environment. Don't use power tools in damp or wet locations, or expose them to rain.
 - c) Do not operate power tools in explosive atmospheres, such as in the presence of flammable liquids, gases or dust. Power tools create sparks which may ignite the fumes or dust.
 - d) Keep children and bystanders away while operating a power tool. Distractions can cause you to lose control.
 - e) Make your workshop child proof with padlocks, master switches, or by removing starter keys.
- 2) Electrical safety
 - a) Do not expose power tools to rain or wet conditions. Water entering a power tool will increase the risk of electric shock.
 - b) Do not abuse the cord. Never use the cord for carrying, pulling or unplugging the power tool. Keep cord away from heat, oil, sharp edges or moving parts. Damaged or entangled cords increase the risk of electric shock.
 - c) Use a proper extension cord and make sure it is in good condition. When using an extension cord, be sure to use one heavy enough to carry the current your machine draws. An undersized cord causes a drop in line voltage resulting in loss of power and overheating. Table 1 shows the correct cord gauge to use depending on cord length and nameplate ampere rating. If in doubt, use the next heavier gage. The smaller the gage number, the heavier the cord.
- 3) Personal safety
 - a) Stay alert, watch what you are doing and use common sense when operating a power tool. Do not use a power tool while you are tired or under the influence of drugs, alcohol or medication. A moment of inattention while operating power tools may result in serious personal injury.
 - b) Always wear safety glasses. Everyday eyeglasses only have impact resistant lenses, they are NOT safety glasses.
 - c) Use safety equipment. Use a face or dust mask when the cutting operation is dusty. Safety equipment such as a dust mask, nonskid safety shoes, hard hat, or hearing protection used for appropriate conditions reduces personal injuries.
 - d) Avoid accidental starting. Make sure the switch is in the off position before plugging in. Carrying power tools with your finger on the switch or plugging in power tools with the switch on invites accidents.
 - e) Remove any adjusting key or wrench before turning the power tool on. A wrench or a key left attached to a rotating part of the power tool may result in personal injury.
 - f) Do not overreach. Keep proper footing and balance at all times. This enables better control of the power tool in unexpected situations.
 - g) Secure workpieces. Use clamps or a vise to hold work when practical. This is safer than using your hand and it frees both hands to operate the tool.
 - h) Never stand on the machine. Serious injury could occur if the tool tips or if the cutting tool is unintentionally contacted.
 - i) Dress properly. Do not wear loose clothing or jewelry. Keep your hair, clothing and gloves away from moving parts. Loose clothes, jewelry or long hair can be caught in moving parts.
 - j) If devices are provided for the connection of dust extraction and collection facilities, ensure these are connected and properly used. Use of these devices can reduce dust-related hazards.
- 4) Power tool use and care
 - a) Keep guards in place and in working order.
 - b) Do not force the power tool. Use the correct power tool for your application. The correct power tool will do the job better and safer at the rate for which it was designed.
 - c) Use right tool. Don't force tool or attachment to do a job for which it was not designed.
 - d) Do not use the power tool if the switch does not turn it on and off. Any power tool that cannot be controlled with the switch is dangerous and must be repaired.
 - e) Disconnect the plug from the power source and/or the battery pack from the power tool before making any adjustments, changing accessories, or storing power tools. Such preventive safety measures reduce the risk of starting the power tool accidentally.
 - f) Never leave tool running unattended. Turn power off. Don't leave tool until it comes to a complete stop.
 - g) Store idle power tools out of the reach of children and do not allow persons unfamiliar with the power tool or these instructions to operate the power tool. Power tools are dangerous in the hands of untrained users.
 - h) Maintain power tools. Check for misalignment or binding of moving parts, breakage of parts and any other condition that may affect power tool operation. If damaged, have the power tool repaired before use. Many accidents are caused by poorly maintained power tools.
 - i) Keep cutting tools sharp and clean. Properly maintained cutting tools with sharp cutting edges are less likely to bind and are easier to control.
 - j) Use the recommended speed for the cutting tool or accessory and workpiece material.
 - k) Only use parts and accessories recommended by the manufacturer. Consult the owner's manual for recommended accessories. Using improper accessories may cause personal injury.
 - l) Use the power tool, accessories and tool bits etc., in accordance with these instructions and in the manner intended for the particular type of power tool, taking into account the working conditions and the work to be performed. Use of the power tool for operations different from those intended could result in a hazardous situation.
- 5) Service
 - a) Have your power tool serviced by a qualified repair person using only identical replacement parts. This ensures that the safety of the power tool is maintained.
- 6) Additional Safety Rules for the DK5100 Pro Series Pocket-Hole Machine
 - a) Before making any adjustments or performing maintenance, disconnect the machine from the air supply. Cycle the machine via the foot switch several times to remove air from the system.
 - b) Do not operate the machine without the acrylic top plate securely fastened in place using the provided lock-down screws. Doing so increases your chances of injury or death.
 - c) Keep hands away from the rotating bits and workpiece clamps when operating the machine.
 - d) Make sure the bits are completely withdrawn from the workpiece and come to a complete stop before adjusting the workpiece position.
 - e) Be aware of kickbacks. Kickbacks occur when the workpiece binds while being drilled, causing it to twist, jump, and possibly become airborne. To avoid kickbacks and potential injury, always use sharp drill bits, keep the machine aligned and properly maintained, and adequately secure and support the workpiece.
 - f) Secure the machine to prevent tipping or sliding. Never stand on the machine.
 - g) Follow all lubrication and maintenance practices detailed in the instruction manual.
 - h) This machine is designed for a specific application. Do not modify and/or use it for any other application. If you have questions relative to the application of the machine, DO NOT use it until you have contacted Kreg Tool Company and have been advised accordingly.

GENERAL SAFETY INSTRUCTIONS

GUIDELINES FOR EXTENSION CORD USE

Extension cords are only to be used for temporary purposes. They do not replace the need for installation of outlets and proper wiring where necessary.

In the shop and on construction sites:

1. Extension cords with an equipment grounding conductor must be used at all times.
2. Extension cords must be protected from damage, and not run through doorways or windows where the doors or windows may close, causing damage to the cord.
3. Extension cords should be a minimum of 16 AWG and be rated for the equipment in use.
4. Extension cords must be periodically inspected to ensure that the insulation and conductivity of the wires are not compromised.
5. Extension cords should not be run through water or allowed to have connections that may be exposed to accumulated water

TABLE 1

Nameplate Amperes @120 V	Extension Cord Length					
	25'	50'	75'	100'	150'	200'
	Recommended Wire Gauge					
0 -5	16	16	16	14	12	12
5.1 - 8	16	16	14	12	10	NR
8.1 -12	14	14	12	10	NR	NR
12.1 - 16	12	12	NR	NR	NR	NR

NR – Not Recommended

⚠ WARNING: This product can expose you to chemicals including lead, which is known to the State of California to cause cancer, birth defects or reproductive harm. For more information go to www.P65Warnings.ca.gov.

⚠ WARNING: Drilling, sawing, sanding or machining wood products can expose you to wood dust, a substance known to the State of California to cause cancer. Avoid inhaling wood dust or use a dust mask or other safeguards for personal protection. For more information go to www.P65Warnings.ca.gov/wood.

WARRANTY

DK SERIES FULLY AUTOMATIC POCKET HOLE MACHINES

Do not return the machine to the dealer for warranty service. For all warranty issues, contact Kreg Tool Company Customer Service at the address or phone number below.

Kreg Tool Company warrants to authorized distributors of Kreg products and original purchasers from such distributors, the DK5100 pocket-hole machine to be free from defects in materials and workmanship for a five-year period from the date of delivery to the original purchaser. The motors and other working parts of the machine carry a one (1) year warranty from the date of delivery to the original purchaser. The drill guides carry a lifetime warranty. Kreg, at its option, will repair or replace any product or component part thereof proving defective during the warranty period.

This warranty only applies to products used in accordance with all instructions set forth in catalogs and manuals furnished by Kreg Tool Company as to operation, maintenance and safety.

This warranty does not apply to (1) items normally consumed or requiring replacement due to normal wear (drill bits, lubricants, etc.); (2) the cost of removal of components if such removal is authorized by Kreg Tool Company; (3) shipment to Kreg Tool Company's repair facility; or (4) reinstallation of components.

This warranty becomes effective only when the accompanying card or online form (available at www.kregtool.com) is fully and properly completed and returned to Kreg Tool Company within ten (10) days from date of delivery to the original purchaser.

This warranty is null and void if the product has been subjected to (1) misuse, abuse, or improper service or storage; (2) accident, neglect, damage, or other circumstances beyond Kreg Tool Company control; and (3) modifications, disassembly, tampering, alterations, or repairs outside of the Kreg Tool Company factory not authorized by Kreg Tool Company. This warranty does not apply to (1) any product not bearing the original serial-number plate; (2) non-original purchasers; and (3) normal wear and tear, corrosion, abrasion, or repairs required due to natural causes or acts of God.

To obtain warranty service, contact the distributor from whom the pocket-hole machine was purchased or contact Kreg Tool Company directly. Proof of purchase is required for remedy under the terms of this warranty. Kreg Tool Company assumes no responsibility for products returned without prior authorization. Kreg Tool Company obligations under this warranty shall be exclusively limited to repairing or replacing (at Kreg Tool Company option) products determined by Kreg Tool Company to be defective upon delivery to the Kreg Tool Company factory and inspection by Kreg Tool Company technicians. Under no circumstance shall Kreg Tool Company be liable for incidental or consequential damages resulting from defective products, nor shall Kreg Tool Company liability exceed the purchase price paid by the original purchaser.

This is the Kreg Tool Company sole warranty. Any and all other warranties implied by law, including any warranties for merchantability or fitness for a particular purpose, are hereby limited to the duration of this warranty. Kreg Tool Company shall not be liable for any loss, damage, or expense directly or indirectly related to the use of its products or from any other cause or for consequential damages including without limitation, loss of time, inconvenience, and loss of production. The warranty contained herein may not be modified and no other warranty, expressed or implied, shall be made by or on behalf of Kreg Tool Company.

Register your warranty within ten (10) days of date of delivery. Warranty service will not be provided without registration.

Keep a copy of this form for your records.

For your records the following information will be useful in the event warranty service is required. For a complete record, attach a copy of the purchase invoice to this form.

Date of Purchase: ___/___/___

Purchased From: _____

Serial Number: _____

(serial number located on front edge of work surface plate)

DK5100 - PNEUMATIC PARTS DIAGRAM

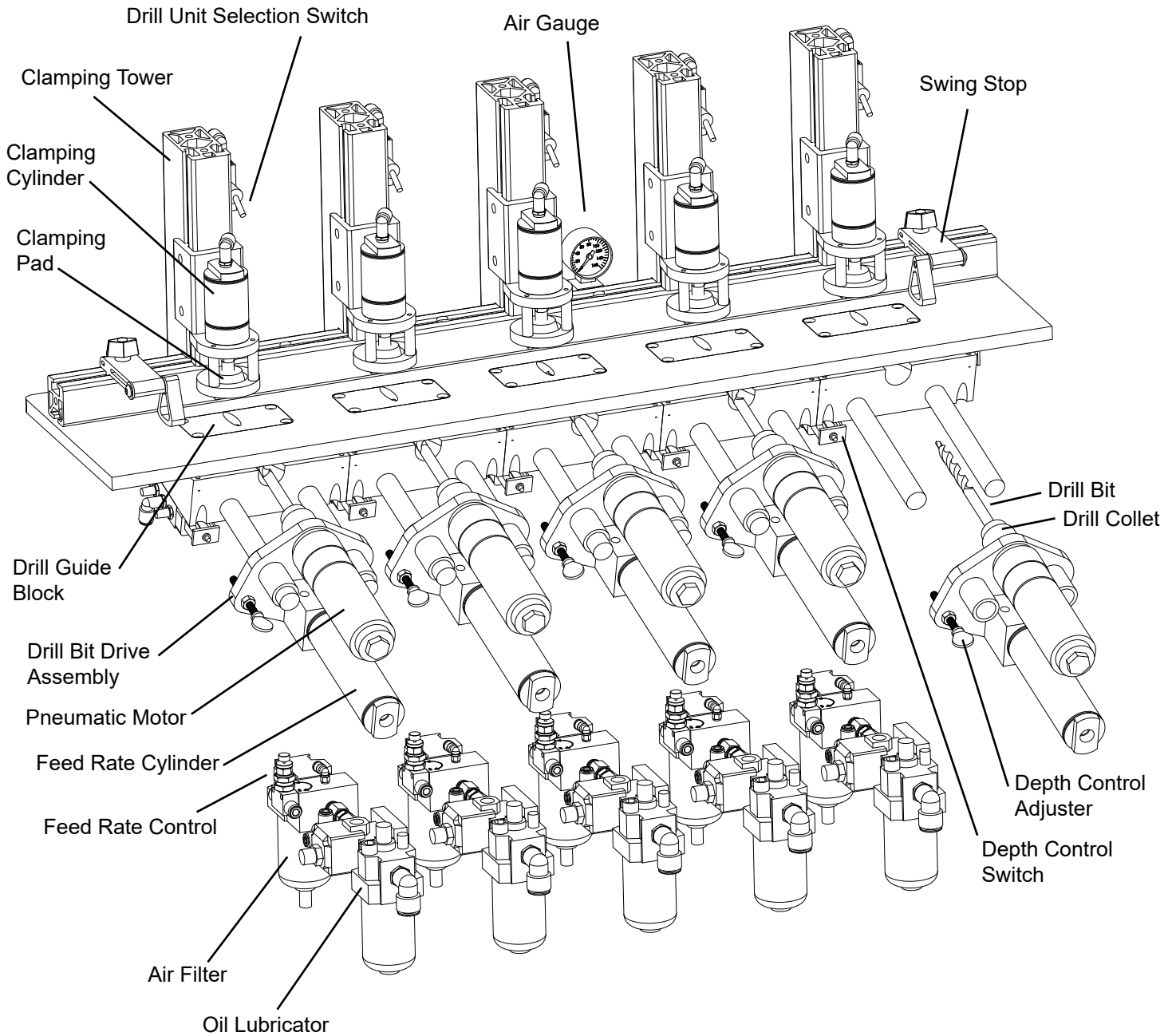

DK5100

Machine Requirements

To receive adequate air supply from your air compressor, this all-pneumatic machine features $\frac{3}{8}$ " [10mm] high-flow fittings. Use on a system with $\frac{1}{2}$ " [13mm] or larger piping and make the connection to the machine with a $\frac{3}{8}$ " [10mm] hose. Restricting air flow with a smaller-diameter hose or connector may degrade machine performance. Maintain the shortest possible distance between your air compressor and the machine and use the shortest possible hose.

ATTENTION Recommended air pressure for the DK5100: 120 psi. [827 kPa].

For a machine in daily use, lubricate the pneumatic drill at least once per month, using a grease gun and the needle-point zerk fitting included with your machine. Kreg recommends two pumps of Sta-Lube Extreme Pressure Moly-Graph® Multi-Purpose Grease (Fastenal, 1.800.272.8963, www.fastenal.com) or equivalent.

WARNING: Before lubricating the drill, disconnect the machine from the air supply. Cycle the machine via the foot switch several times to remove air from the system.

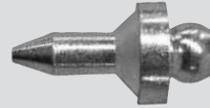

GREASE ZERK FITTING INCLUDED WITH MACHINE



You may need to rotate the drill to gain access to the grease port. Use a wrench to rotate the black fitting at the rear of the drill clockwise.

Secure the Acrylic Top

Position the acrylic top on the cabinet and secure it with two lock-down screws and the $\frac{1}{8}$ " hex wrench provided.

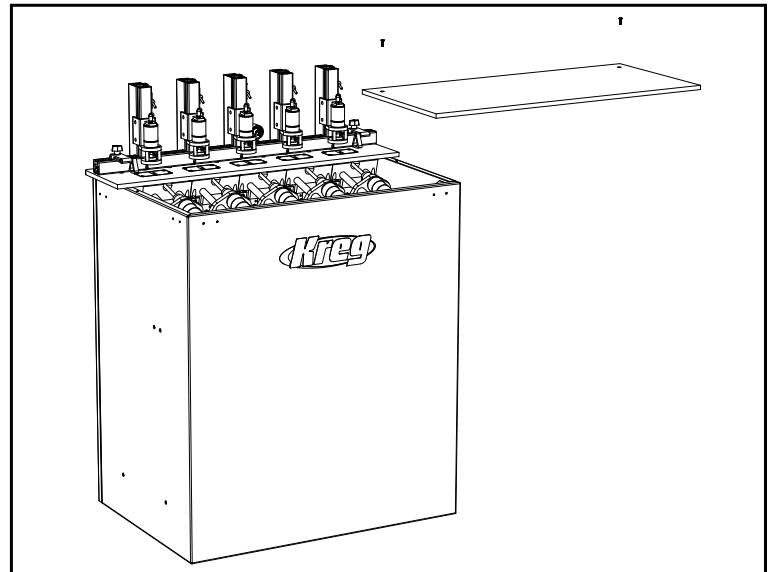

Drill Unit Selection

The DK5100 simultaneously drills up to five pocket holes at 6-inch centers. Each drill unit can be independently switched off or on. Selecting the off position prevents the drill from actuating during the drilling cycle, allowing the operator to vary the pocket hole spacing.



Changing Drill Bits

A DKDB drill bit drills 4000–5000 holes in Oak before re-sharpening. This baseline was established using the factory settings for Feed Rate Control described in this manual. Adjust your sharpening schedule for your settings and the material being drilled.

⚠ WARNING: Before changing the drill bit, disconnect the machine from the air supply. Cycle the machine via the foot switch several times to remove air from the system.

- (1) Remove the acrylic top plate.
- (2) Loosen the collet with the provided wrenches.
- (3) Slide the drill bit out of the collet and into the drill-guide block until the end of the bit clears the collet. Slightly angle the bit to avoid the collet and withdraw the bit from the drill-guide block.
- (4) Insert a new or re-sharpened drill bit into the collet, aligning the flats on the bit shank with the collet jaws.
- (5) Tighten the collet.
- (6) Re-set the counter to track drill-bit life and replace the top plate.

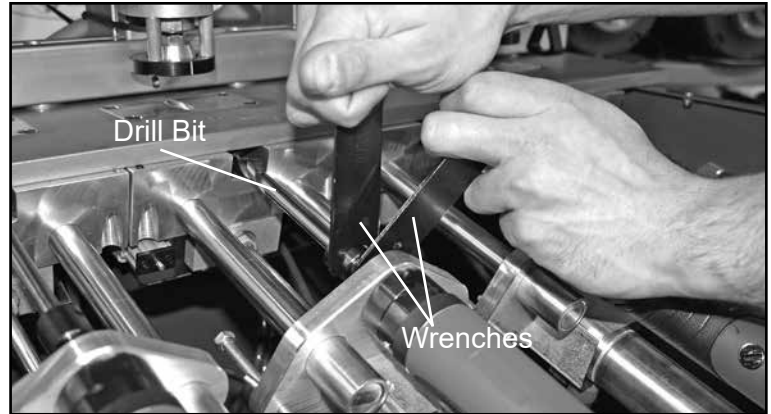

Drilling-Depth Stop

The drilling-depth stop controls drill-bit forward travel and the drill-feed cylinder cycle. When the depth stop contacts the depth control switch, the forward travel of the drill bit stops and reverses, completing the drilling cycle.

⚠ WARNING: Before adjusting the drilling-depth stop, disconnect the machine from the air supply. Cycle the machine via the foot switch several times to remove air from the system.

- (1) Loosen the wing nut.
- (2) Push the drill-bit drive assembly forward to provide the following clearances between the drill-bit pilot point and the fence:
 - $\frac{1}{2}$ " [13mm] and $\frac{3}{4}$ " [19mm] material: $\frac{1}{8}$ " [3mm] clearance
 - $1\frac{1}{2}$ " [38mm] material: 1" [25mm] clearance
- (3) Adjust the depth-control adjuster until the head fully depresses the plunger on the depth-control switch.
- (4) Tighten the lock nut.
- (5) Pull the drill-bit drive assembly back until it stops.

⚠ ATTENTION Sharpening a drill bit makes it shorter. When installing a sharpened bit, readjust the drilling depth.

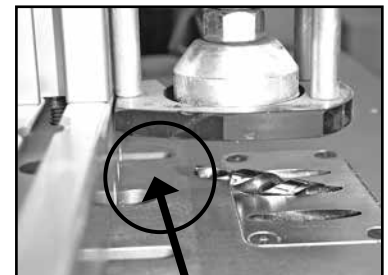
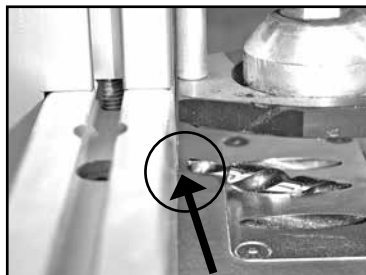
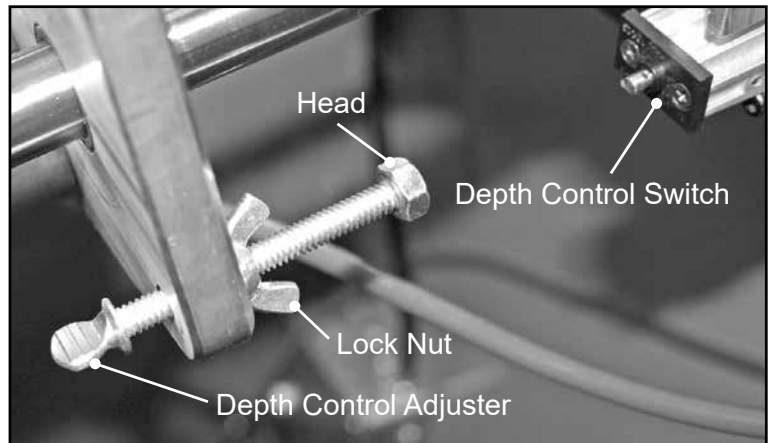

Stock-Thickness Adjustment Fence Settings

The fence should be positioned so the pocket screw emerges at the center of the material thickness. When adjusting the fence, make sure it remains parallel to the front edge of the guide block.

- (1) Loosen the four socket-head screws located in the slot in the top of the fence.
- (2) Align the face of the fence with the letter scales on the edges of the base plate that correspond to the material thickness.
- (3) Tighten the socket-head screws.

Setting A for $\frac{1}{2}$ " [13mm] material
 Setting B for $\frac{3}{4}$ " [19mm] material
 Setting C for $1\frac{1}{2}$ " [38mm] material

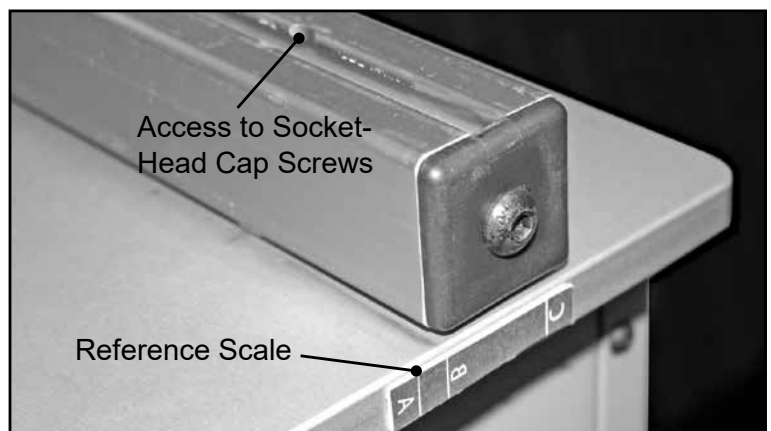

Clamping-Cylinder Height

The factory cylinder-height position accommodates $\frac{1}{2}$ "– $\frac{3}{4}$ " [13mm–19mm] material thicknesses. For thicker material, adjust the cylinder height.

⚠ WARNING: Before adjusting clamping-cylinder height, disconnect the machine from the air supply. Cycle the machine via the foot switch several times to remove air from the system.

- (1) Loosen two socket-head screws on each side of the clamping cylinder bracket.
- (2) Adjust the clamping cylinder to allow the workpiece to pass under the clamp pad.
- (3) Tighten the socket-head screws.

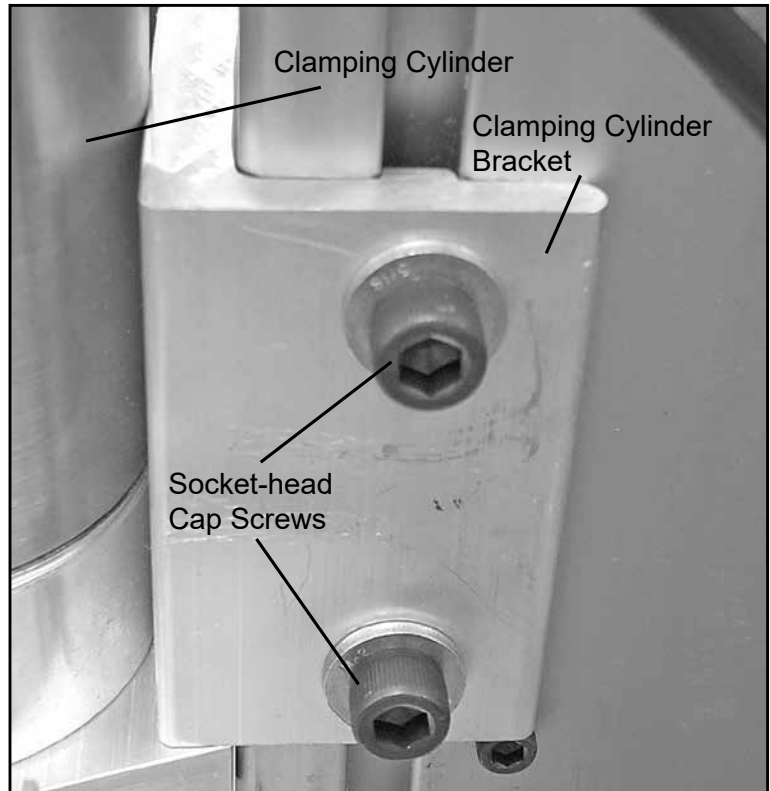

Feed Rate

The feed-rate control valve controls the speed at which the drill bit advances into the material. The factory setting optimizes drill-bit life. The valve can be adjusted when a faster or slower rate feed is desired. Adjustment is only recommended for experienced users who consistently drill the same thickness and type of material.

- (1) Loosen the locking collar and rotate the screw in the direction of the desired change in feed rate, F for faster and S for slower. A small rotation results in a large change in feed rate.
 - (2) Tighten the locking collar.
- To return to the factory settings after changing the feed rate:
- (1) Loosen the locking collar.
 - (2) Turn the screw clockwise until it stops.
 - (3) Turn the screw counter-clockwise four complete turns for the DK1100 FE and three complete turns for the DK3100.
 - (4) Tighten the locking collar.

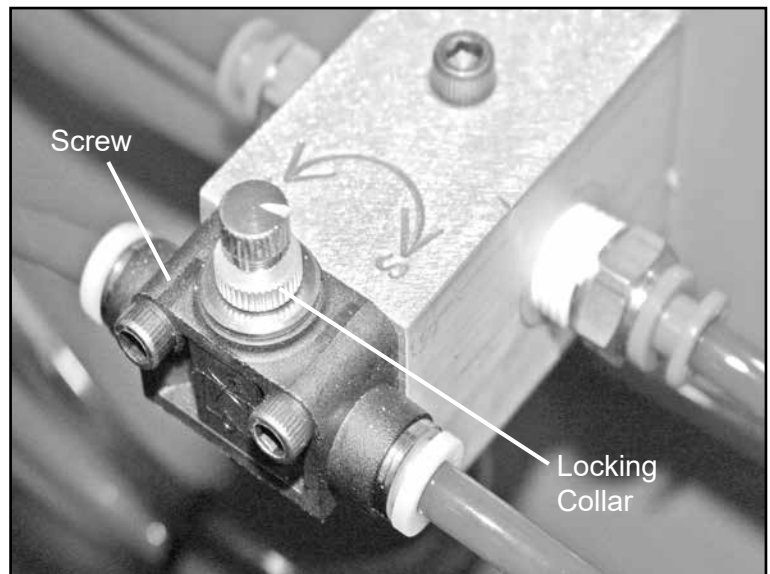

Clamping Duration

The clamping duration control adjusts the amount of time the pneumatic clamp engages the material before, during, and after drilling.

- (1) Loosen the locking collar
- (2) Turn the screw clockwise to increase clamping time, counter-clockwise to decrease clamping time.
- (3) Tighten the locking collar.

⚠ ATTENTION If the workpiece lifts off of the drill guide block during drilling, either the clamping cylinder height, the clamping duration, or both must be adjusted.

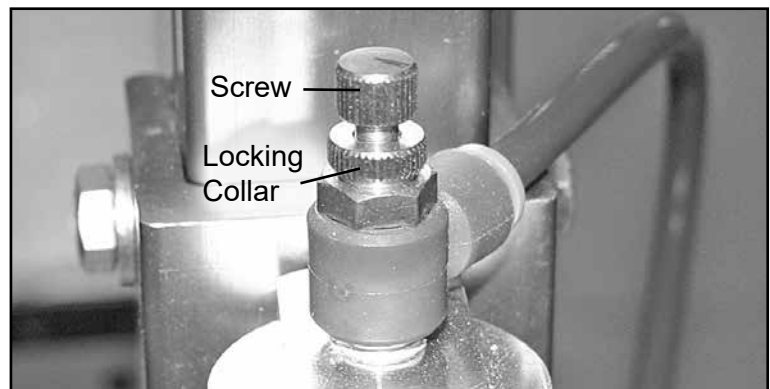

Swing Stops

Two swing stops assist in drilling pocket holes in the same location on multiple work pieces. When not used, the swing stop pivots out of the way, allowing the work piece to slide underneath and rest against the fence. To change swing-stop location, loosen the knob, move the stop to the new location and tighten the knob.

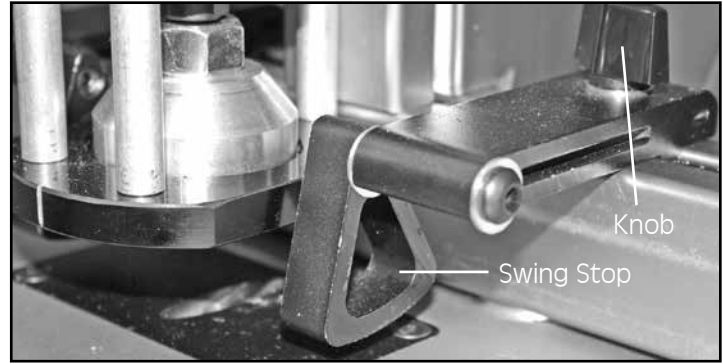

Air-System Filter

The air-system filter maintains a clean, moisture-free supply of compressed air to the machine and periodically must be drained.

- (1) Push the drain valve up toward the reservoir or to the side.
- (2) Let system air pressure blow out the collected fluid.
- (3) Release the drain valve.

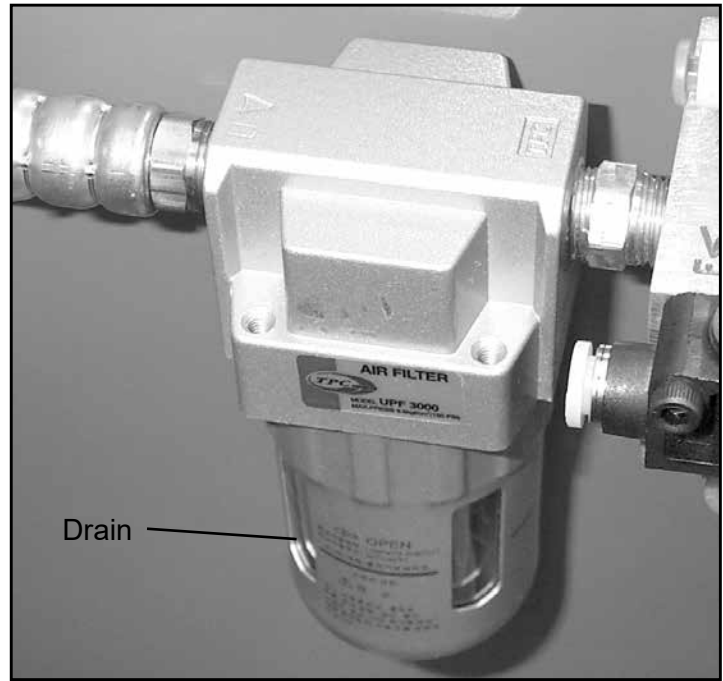

WARNING: Before removing the filter reservoir to clean or replace the filter, disconnect the machine from the air supply. Cycle the machine via the foot switch several times to remove air from the system.

Air-System Lubricator

The air-system lubricator is filled with air-motor oil and maintains proper pneumatic motor lubrication. The lubricator is factory set at $\frac{1}{2}$ turn open. The oil level should be routinely checked and refilled with air motor oil comparable to that provided. Normal use of the machine causes a light oil film to accumulate on the underside of the top plate where the pneumatic motor exhausts.

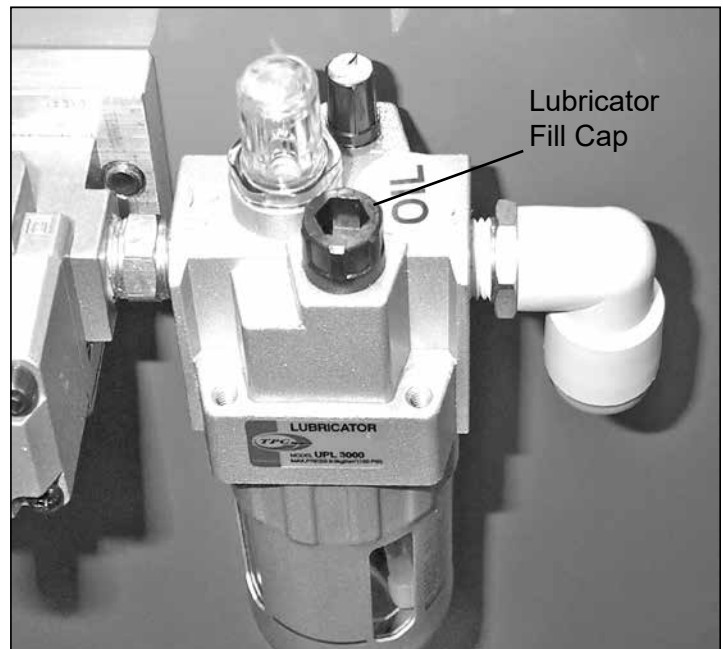

WARNING: Before filling the lubricator, disconnect the machine from the air supply. Cycle the machine via the foot switch several times to remove air from the system.