



Drawer Slide Jig

Owner's Manual

Guide d'utilisation

Manual del propietario

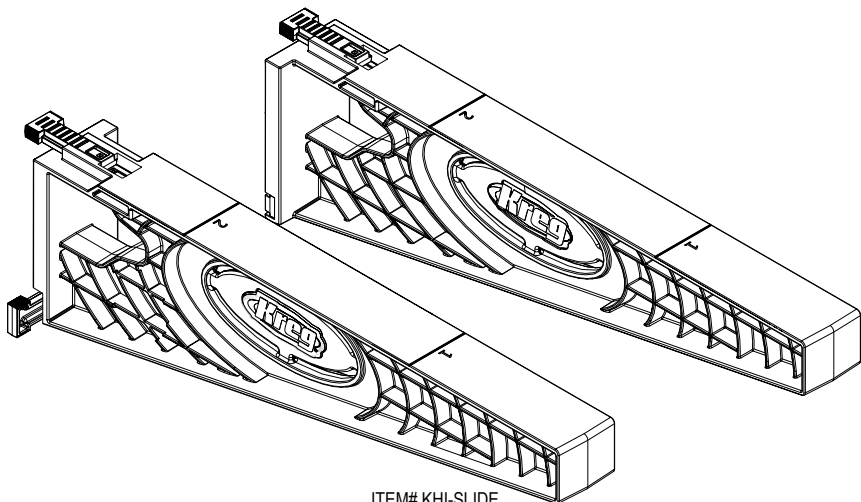

ITEM# KHI-SLIDE

Follow your drill manufacturer's instructions and safety guidelines.

Always wear eye protection.

Keep your body and hands away from sharp bit edges and moving parts.

Keep your hands and fingers away from the back face of the workpiece when drilling.

⚠ WARNING: This product can expose you to chemicals including Acrylonitrile and other chemicals, which are known to the State of California to cause cancer and reproductive harm. For more information go to www.P65Warnings.ca.gov.

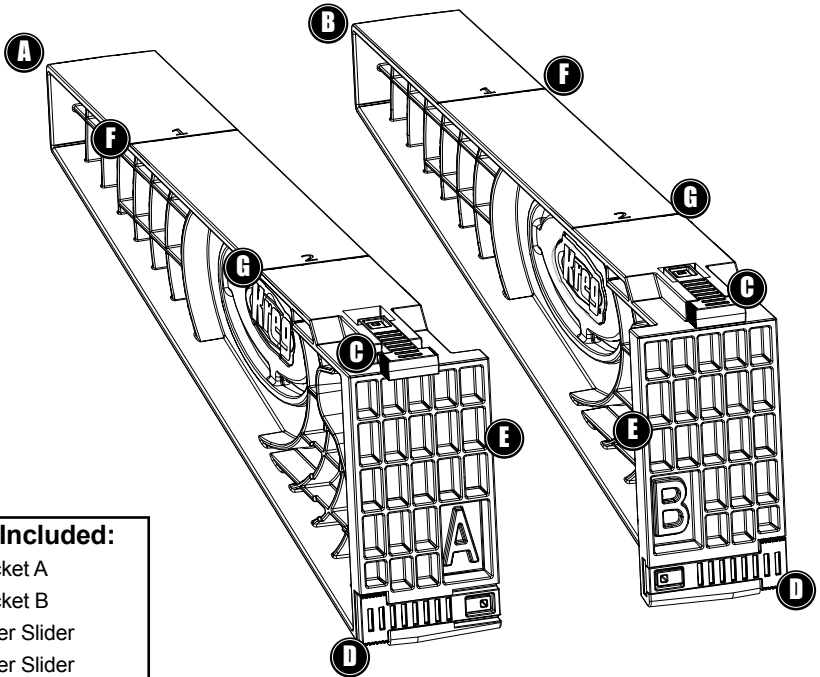
PARTS**Items Included:**

- (A) Bracket A
- (B) Bracket B
- (C) Upper Slider
- (D) Lower Slider
- (E) Bracket Flange
- (F) Line 1
- (G) Line 2

⚠ ATTENTION Use the Kreg Drawer Slide Jig in conjunction with the drawer-slide manufacturer's instructions. To install drawer slides in face-frame cabinets, slide-mounting rails must be attached to the inside faces of the cabinet sides to provide a drawer-slide mounting surface that is flush with the inside edges of the face-frame stiles. Drawer boxes must be mounted before the false-fronts are attached. The Drawer Slide Jig cannot be used to mount a drawer at the bottom of a cabinet. To mount a drawer at the bottom of a cabinet, see the section **INSTALLING A DRAWER AT THE BOTTOM OF A CABINET**.

⚠ ATTENTION If installation instructions supplied with your drawer slides are vague, incomplete, or nonexistent, please contact the manufacturer or hardware supplier for complete installation information. Major hardware manufacturers have this information on their Web sites.

FACE-FRAME CABINETS

MOUNTING DRAWER-SLIDE CABINET MEMBERS

$\frac{3}{4}$ -Extension and Full-Extension Drawer Slides

Position the Brackets

- Extend the Upper Slider and Lower Slider on each bracket.
- Position Bracket A on the left side of the cabinet, Bracket B on the right side, with both Brackets extending into the cabinet.
- Place the Upper Sliders on the top edge of the face-frame rail that is under the drawer opening and the Lower Sliders against the inside faces of the face-frame stiles.
- Clamp the Brackets to the face frame.

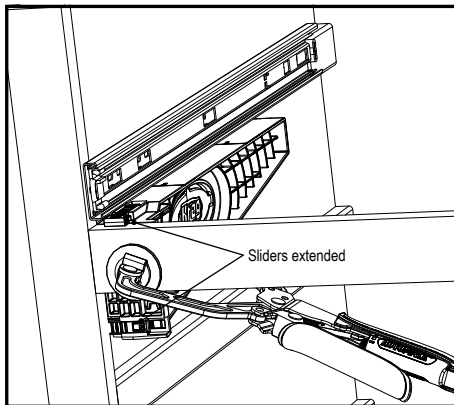

Fasten the Drawer-Slide Cabinet Members

- Place the drawer slides on the brackets.
For overlay drawer fronts, follow the drawer-slide manufacturer's instructions for the slide setback distance from the face of the stile. For inset drawer fronts, add the thickness of the drawer front.
- Using the vertical mounting slots in the drawer-slide cabinet members as guides, drill pilot holes and screw the cabinet members in place.
- Remove the Brackets from the cabinet.

MOUNTING DRAWER-SLIDE CABINET MEMBERS

Under-Mount Drawer Slides

Position the Brackets

- Extend only the Lower Slider on each bracket.
- Position Bracket A on the left side of the cabinet, Bracket B on the right side, with both Brackets extending into the cabinet.
- Position the Brackets with the top surfaces of the Upper Sliders flush with the top surface of the face-frame rail that is under the drawer opening and the Lower Sliders against the inside faces of the face-frame stiles.
- Clamp the Brackets to the face frame.

Fasten the Drawer-Slide Cabinet Members

- Place the cabinet members of the drawer slides on the Brackets. For overlay drawer fronts, follow the drawer slide manufacturer's instructions for the slide setback distance from the face of the stile. For inset drawer fronts, add the thickness of the drawer front.
- Using the vertical mounting slots in the drawer-slide cabinet members as guides, drill pilot holes and screw the slides in place.
- Remove the Brackets from the cabinet.

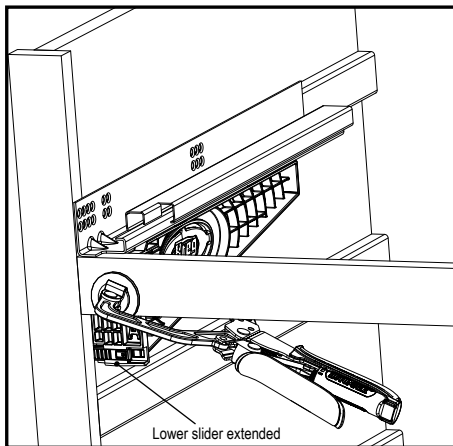

⚠ ATTENTION Where the inside edges of the face-frame stiles are flush with the inside faces of the cabinet sides, do not extend the Lower Sliders. Clamp the Brackets to the cabinet sides. Make sure the clamp pad bears on the Bracket ribs, not the webbing between the ribs, including the web area with the Kreg logo. Clamping with the clamp pad on the webbing could crack the Bracket.

MOUNTING DRAWER-SLIDE CABINET MEMBERS

 $\frac{3}{4}$ -Extension and Full-Extension Drawer Slides

ATTENTION Do not use the Brackets when installing the drawer members of $\frac{3}{4}$ -extension drawer slides with flanges that extend under the sides of the drawers. In this case, turn the drawer upside down on your workbench and install the drawer members, observing the manufacturer's setback distance from the front of the drawer.

Position the Brackets

- Extend the Upper Slider on each bracket.
- Position Bracket A on the left side of the cabinet and Bracket B on the right side with both Brackets extending out from the face of the cabinet.
- Place the Upper Slider on the top edge of the face-frame rail that is under the drawer opening.
- Clamp the Brackets to the face frame.

Fasten the Drawer-Slide Drawer Members

- Place the drawer box on the Brackets with the front of the box aligned with **Line 1** on the top face of each bracket.
- Extend the drawer slides. Follow the drawer-slide manufacturer's instructions for the slide setback distance from the front of the drawer box.
- Using the mounting holes in the drawer-slide drawer members as guides, drill pilot holes for the front and middle screws and screw the slides to the drawer box.
- For $\frac{3}{4}$ -extension drawer slides, remove the drawer from the cabinet. Using the rear mounting holes as guides, drill pilot holes and drive the screws.
- For full-extension drawer slides, extend the drawer all the way. Using the rear mounting holes as guides, drill pilot holes and drive the screws.
- Remove the Brackets from the cabinet.
- Check the drawer operation and adjust the position of the drawer box as necessary by adjusting the position of the drawer-slide cabinet members. When satisfied with the fit, use the round holes in the drawer-slide cabinet members as guides to drill pilot holes and drive screws to fix the drawer box position.

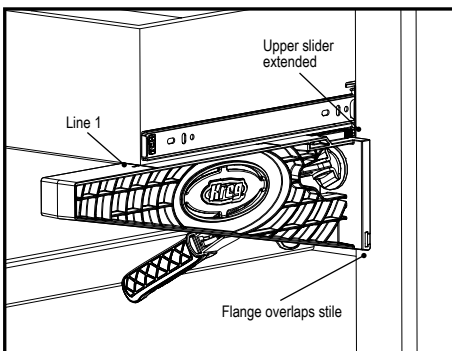
**Under-mount Drawer Slides**

- Follow the drawer-slide manufacturer's instructions for installing the drawer members.

⚠ ATTENTION When clamping the Brackets to the side of the cabinet, make sure the clamp pad bears on the Bracket ribs, not the webbing between the ribs, including the web area with the Kreg logo. Clamping with the clamp pad on the webbing could crack the Bracket.

MOUNTING DRAWER-SLIDE CABINET MEMBERS

All Drawer Slides

Position the Brackets

- Mark the locations of the bottoms of the drawer slides on the inside faces of the cabinet.
- Position Bracket A on the right side of the cabinet, Bracket B on the left side, with both Brackets extending into the cabinet and the Bracket Flanges against the front edges of the cabinet sides.
- Align the top edges of the Brackets with the drawer-slide location marks and clamp the Brackets to the cabinet sides.

Fasten the Drawer-Slide Cabinet Members

- Place the drawer slides on the Brackets. For under-mount slides, place just the cabinet members of the slides on the Brackets. For overlay drawer fronts, follow the drawer-slide manufacturer's instructions for the slide setback distance from the front edge of the cabinet side. For inset drawer fronts, add the thickness of the drawer front.
- Using the vertical mounting slots in the drawer-slide cabinet members as guides, drill pilot holes and screw the slides in place.
- Remove the Brackets from the cabinet.

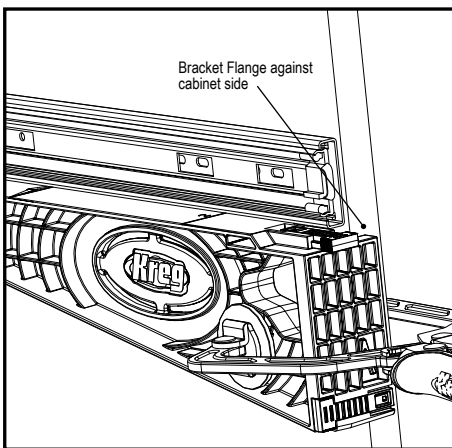

MOUNTING DRAWER-SLIDE DRAWER MEMBERS

3/4-Extension and Full-Extension Drawer Slides

⚠ ATTENTION Do not use the Brackets when installing the drawer members of 3/4-extension drawer slides with flanges that extend under the sides of the drawers. In this case, turn the drawer upside down on your workbench and install the drawer members, observing the manufacturer's setback distance from the front of the drawer.

Position the Brackets

- Position Bracket A on the right side of the cabinet, Bracket B on the left side, with both Brackets extending out from the face of the cabinet.
- Align **Line 2** on the top face of each Bracket with the front end of each drawer slide, push the Brackets up against the bottom of the slides, and clamp the Brackets to the cabinet sides.

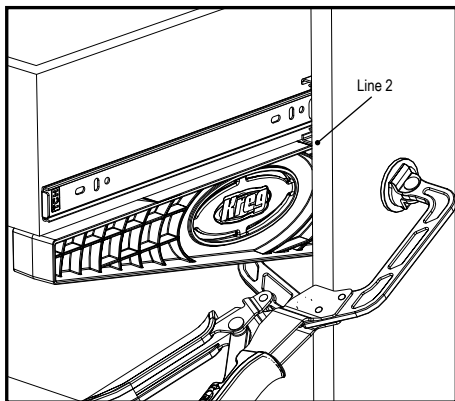

Fasten the Drawer-Slide Drawer Members

- Place the drawer box on the Brackets with the front of the box aligned with the ends of the brackets.
- Extend the drawer slides. Follow the drawer-slide manufacturer's instructions for the slide setback distance from the front of the drawer box.
- Using the mounting holes in the drawer-slide drawer members as guides, drill pilot holes for the front and middle screws and screw the slides to the drawer box.
- For 3/4-extension drawer slides, remove the drawer from the cabinet. Using the rear mounting holes as guides, drill pilot holes and drive the screws.
- For full-extension drawer slides, extend the drawer all the way. Using the rear mounting holes as guides, drill pilot holes and drive the screws.
- Remove the Brackets from the cabinet.
- Check the drawer operation and adjust the position of the drawer box as necessary by adjusting the position of the drawer-slide cabinet members. When satisfied with the fit, use the round holes in the drawer-slide cabinet members as guides to drill pilot holes and drive screws to fix the drawer-box position.

Under-mount Drawer Slides

- Follow the drawer-slide manufacturer's instructions for installing the drawer members.

INSTALLING A DRAWER AT THE BOTTOM OF A CABINET**Mounting Drawer-Slide Cabinet Members**

- Place a ¼" [6mm]-thick, 1½" [38mm]-wide spacer board that is as long as the drawer slide between the bottom of the cabinet and each drawer slide.
- For overlay drawer fronts, follow the drawer-slide manufacturer's instructions for the slide setback distance from the face of the stile (for face-frame cabinets) or the front edge of the cabinet side (for frameless cabinets). For inset drawer fronts, add the thickness of the drawer front.
- Using the vertical mounting slots in the drawer-slide cabinet members as guides, drill pilot holes and screw the cabinet members in place.

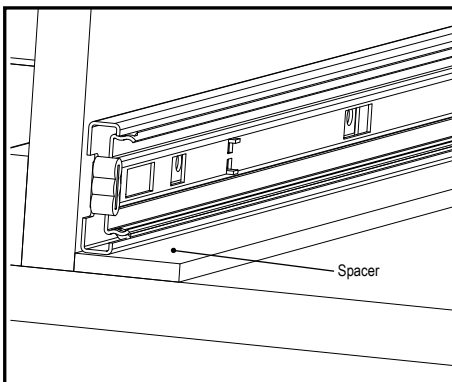
**Under-mount Drawer Slides**

- Follow the drawer-slide manufacturer's instructions for installing the drawer members.

⚠ ATTENTION When installing the drawer members of $\frac{3}{4}$ -extension drawer slides with flanges that extend under the sides of the drawers, turn the drawer upside down on your workbench and install the drawer members, observing the manufacturer's setback from the front of the drawer.

- Slide the spacers out of the cabinet until they protrude 4" [102mm], keeping the remaining length of the spacers under the drawer slides mounted inside the cabinet.
- Place the drawer box on the spacers with the front of the box aligned with the ends of the spacers.
- Extend the drawer slides. Follow the drawer-slide manufacturer's instructions for the slide setback distance from the front of the drawer box.
- Using the holes in the drawer-slide drawer members as guides, drill pilot holes for the front screws and screw the slides to the drawer box.
- Extend the drawer to expose the middle mounting holes, drill pilot holes and drive the screws.
- For $\frac{3}{4}$ -extension drawer slides, remove the drawer from the cabinet. Using the rear mounting holes as guides, drill pilot holes and drive the screws.
- For full-extension drawer slides, extend the drawer all the way. Using the rear mounting holes as guides, drill pilot holes and drive the screws.
- Remove the spacers.
- Check the drawer operation and adjust the position of the drawer box as necessary by adjusting the position of the drawer-slide cabinet members. When satisfied with the fit, use the round holes in the drawer-slide cabinet members as guides to drill pilot holes and drive screws to fix the drawer-box position.

