

Accu-Cut™



Owner's Manual

Guide d'utilisation

Manual del propietario

Item# KMA2700

Article #KMA2700

Artículo # KMA2700

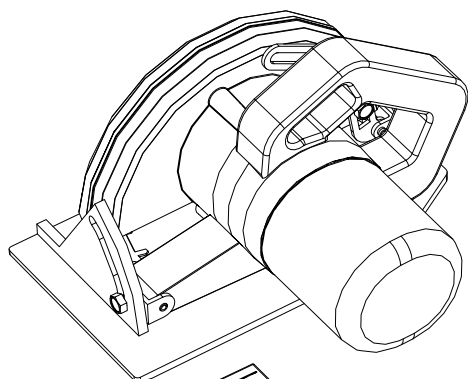

Saw not included
Scie non incluse
No se incluye sierra

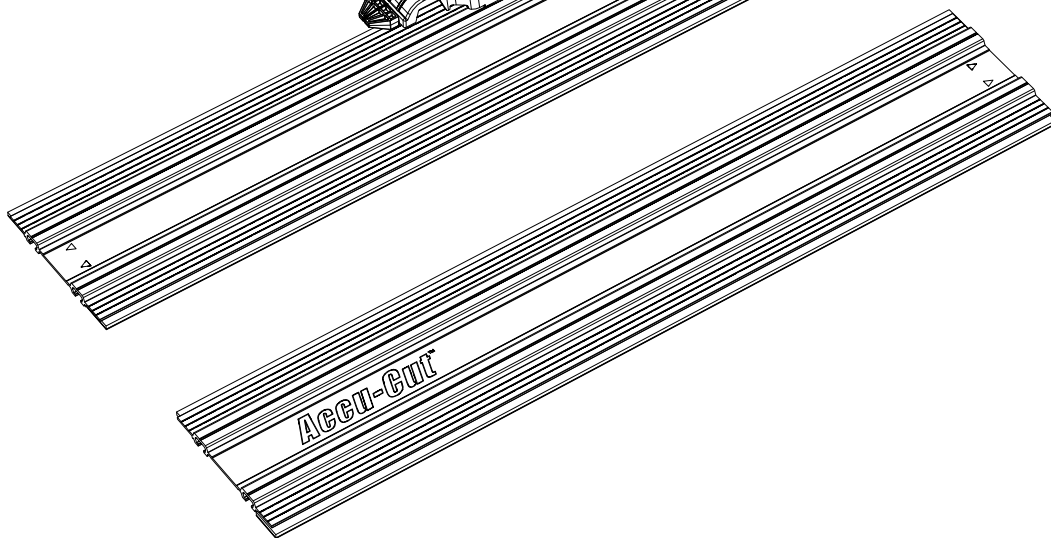
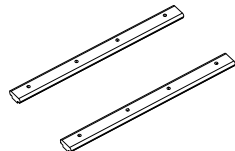
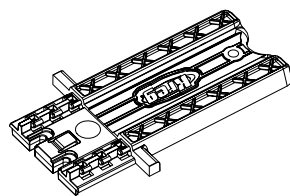
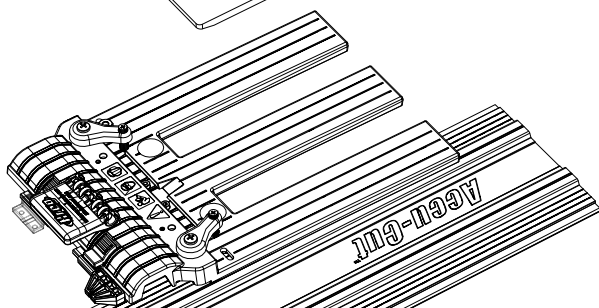

NK9191
Version 6 - 04/2020

General Safety Guidelines

⚠ WARNING When using electric tools, always follow the safety precautions *below* to reduce the risk of fire, electric shock, and personal injury. Read all these instructions before attempting to operate this product. **SAVE THESE INSTRUCTIONS.**

1) Work area safety

- a) Keep work area clean and well lit. Cluttered or dark areas invite accidents.
- b) Don't use power tools in a dangerous environment. Don't use power tools in damp or wet locations, or expose them to rain.
- c) Do not operate power tools in explosive atmospheres, such as in the presence of flammable liquids, gases or dust. Power tools create sparks that can ignite the fumes or dust.
- d) Keep children and bystanders away while operating a power tool. Distractions can cause you to lose control.
- e) Make your workshop child proof. Use padlocks, master switches, or remove starter keys.

2) Electrical safety

- a) Ground electric tools. If the tool is equipped with a three-prong plug, it must be plugged into a grounded three-hole electrical outlet. If the proper outlet is not available, have one installed by a qualified electrician. Never remove the third prong or modify the provided plug in any way.
- b) Do not expose power tools to rain or wet conditions. Water entering a power tool increases the risk of electric shock.
- c) Do not abuse the cord. Never use the cord for carrying, pulling or unplugging the power tool. Keep cord away from heat, oil, sharp edges or moving parts. Damaged or entangled cords increase the risk of electric shock.
- d) Use a proper extension cord and make sure it is in good condition. When using an extension cord, be sure to use one heavy enough to carry the current your power tool draws. An undersized cord causes a drop in line voltage resulting in loss of power and overheating. Table 1 shows the correct cord gauge to use depending on cord length and tool nameplate ampere rating. If in doubt, use the next heavier gauge. The smaller the gauge number, the heavier the cord.
- e) When operating electric tools, avoid body contact with grounded or earthed surfaces such as pipes, radiators, kitchen ranges, and refrigerators. Contact with a grounded surface increases the risk of electric shock.

3) Personal safety

- a) Stay alert, watch what you are doing and use common sense when operating a power tool. Do not use a power tool while you are tired or under the influence of drugs, alcohol or medication. A moment of inattention while operating power tools can result in serious personal injury.
- b) Always wear safety glasses. Everyday eyeglasses are not safety glasses. Safety glasses have specially constructed lenses, frames, and side shields.
- c) Use safety equipment. Use a face or dust mask when the cutting operation is dusty. Safety equipment such as a dust mask, non-skid safety shoes, hard hat, or hearing protection used for appropriate conditions reduces personal injuries.
- d) Avoid accidental starting. Make sure the switch is in the off-position before plugging in. Carrying power tools with your finger on the switch or plugging in power tools that have the switch on invites accidents.
- e) Remove any adjusting key or wrench before turning the power tool on. A wrench or a key left attached to a rotating part of the power tool can result in personal injury.
- f) Do not overreach. Keep proper footing and balance at all times. This enables better control of the power tool in unexpected situations.
- g) Secure workpieces. Use clamps or a vise to hold work when practical. This is safer than using your hand and it frees both hands to operate the tool.
- h) Never stand on the machine. Serious injury can occur if the tool tips or if the cutting tool is unintentionally contacted.

- i) Dress properly. Do not wear loose clothing or jewelry. Keep your hair, clothing and gloves away from moving parts. Loose clothes, jewelry or long hair can be caught in moving parts. Roll up long sleeves to the elbow. Wear protective hair covering to contain long hair.

- j) If devices are provided for the connection of dust extraction and collection equipment, ensure these are connected and properly used. Use of these devices reduces dust-related hazards.

4) Power tool use and care

- a) Keep guards in place and in working order.
- b) Do not force the power tool. Use the correct power tool for your application. The correct power tool will do the job better and safer at the rate for which it was designed.
- c) Use the right tool. Don't force a tool or attachment to do a job for which it was not designed.
- d) Do not use the power tool if the switch does not turn it on and off. Any power tool that cannot be controlled with the switch is dangerous and must be repaired.
- e) Disconnect the plug from the power source and/or the battery pack from the power tool before making any adjustments, changing accessories, or storing power tools. Such preventive safety measures reduce the risk of starting the power tool accidentally.
- f) Never leave a tool running unattended. Turn power off. Do not leave the tool until it comes to a complete stop.
- g) Store idle power tools out of the reach of children and do not allow persons unfamiliar with the power tool and these instructions to operate the power tool. Power tools are dangerous in the hands of untrained users.
- h) Maintain power tools. Check for misalignment or binding of moving parts, broken parts, and any other condition that can affect power tool operation. If damaged, have the power tool repaired before use. Many accidents are caused by poorly maintained power tools.
- i) Keep cutting tools sharp and clean. Properly maintained cutting tools with sharp cutting edges are less likely to bind and are easier to control.
- j) Use the recommended speed for the cutting tool or accessory and workpiece material.
- k) Only use parts and accessories recommended by the manufacturer. Consult the owner's manual for recommended accessories. Using improper accessories can cause personal injury.
- l) Use the power tool, accessories, and tool bits in accordance with these instructions and in the manner intended for the particular type of power tool, taking into account the working conditions and the work to be performed. Use of the power tool for operations different from those intended can result in a hazardous situation.

5) Service

- a) Have your power tool serviced by a qualified repair person using only identical replacement parts. This ensures that the safety of the power tool is maintained.

6) SAFETY INSTRUCTIONS SPECIFIC TO USING THE ACCU-CUT™

- a) Before using the Accu-Cut™, read, understand, and follow the safety warnings and operation instructions included with this product and provided by your saw manufacturer. Keep all guards and safety devices in place.
- b) Wear proper eye, ear, and respiratory protection when operating your saw.
- c) Use a sharp blade designed for the type of material you are cutting.
- d) Always disconnect your saw from power before making adjustments to the saw or Accu-Cut™.
- e) Wipe the guide strips with a damp cloth and remove dust and debris from the workpiece before positioning the track on the workpiece.

General Safety Guidelines

- f) Only use the number of track sections required to make a cut, adding or removing track sections as necessary.
- g) The Accu-Cut™ is designed for use without clamps only with two or more track sections joined together. Do not attempt a cut using only one track section without first clamping the track section to the work piece.
- h) Ensure that the saw blade will not contact the aluminum track during the cut.
- i) Do not attempt a cut when any part of the Accu-Cut™ sled interferes with the operation of the saw blade guard.
- j) Fully support both the workpiece and the cutoff piece to prevent binding and kickback.
- k) Adjust the depth of cut so the saw blade protrudes 1/8" [3mm] through the workpiece during the cut.
- l) Keep your hands away from the saw blade during operation. Do not reach under the workpiece while cutting.
- m) Secure your workpiece to ensure it doesn't move during the cut.
- n) Do not use excessive force when cutting. Maintain a steady and controlled pace.
- o) Allow the saw blade to come to a complete stop before removing the saw/sled assembly from the track.
- p) Do not leave unattended saw resting on the track or starting block.
- q) Maintain your tools and accessories. Check for misalignment or binding of moving parts, loose fasteners, broken parts, and any other condition that may affect safe operation. If an unsafe condition is discovered, correct it before use.

7) Kickback

Kickback is a sudden reaction to a pinched, bound, or misaligned saw blade, causing an uncontrolled saw to lift up and out of the workpiece toward the operator.

8) Causes of kickback

- a) When the blade is pinched or bound tightly by the kerf closing in, the blade stalls and the motor reaction drives the unit rapidly back toward the operator.
- b) If the blade becomes twisted or misaligned in the cut, the teeth at the back edge of the blade can dig into the top surface of the wood causing the blade to climb out of the kerf and propel the saw back toward the operator.

Preventing kickback

Kickback is the result of tool misuse and/or incorrect operating procedures or conditions and can be avoided by taking proper precautions.

- a) Maintain a firm grip with both hands on the saw and position your body and arms to resist kickback forces. Kickback forces can be controlled by the operator if proper precautions are taken.
- b) When blade starts to bind, or when interrupting a cut for

- any reason, release the trigger and hold the saw motionless in the material until the blade comes to a complete stop. Never attempt to remove the saw from the work or pull the saw backward while the blade is in motion. Investigate and take corrective actions to eliminate the cause of blade binding.
- c) When restarting a saw in the workpiece, center the saw blade in the kerf and check that saw teeth are not engaged in the material. If the saw blade is binding, the blade may climb out of the workpiece and kickback as the saw is restarted.
- d) Support large panels to minimize the risk of blade pinching and kickback. Large panels tend to sag under their own weight. Supports must be placed under the panel on both sides of the cut: near the cutline and near the edge of the panel.

- e) Do not use a dull or damaged blade. A dull or improperly sharpened blade produces a narrow kerf, causing excessive friction, blade binding, and kickback.
- f) Blade depth and bevel adjusting locks must be tight and secure before making a cut. If blade adjustment shifts while cutting, it may cause binding and kickback.
- g) Use extra caution when making a plunge cut into existing walls, floors, or other blind areas. The protruding blade may contact unseen objects that can cause kickback.

Guidelines for extension cord use

Extension cords are only to be used for temporary purposes. They do not replace the need for installation of outlets and proper wiring where necessary.

In the shop and on construction sites:

1. Extension cords with an equipment grounding conductor must be used at all times.
2. Extension cords must be protected from damage, and not run through doorways or windows where the doors or windows can close, causing damage to the cord.
3. Extension cords must be a minimum of 16 AWG and be rated for the equipment in use.
4. Extension cords must be periodically inspected to ensure that the insulation and conductivity of the wires are not compromised.
5. Extension cords should not be run through water or allowed to have connections that may be exposed to accumulated water.

TABLE 1

Nameplate Amperes @120 V	Extension Cord Length					
	25'	50'	75'	100'	150'	200'
	Recommended Wire Gauge					
0 - 5	16	16	16	14	12	12
5.1 - 8	16	16	14	12	10	NR
8.1 - 12	14	14	12	10	NR	NR
12.1 - 16	12	12	NR	NR	NR	NR

NR – Not Recommended

⚠ WARNING: This product can expose you to chemicals including Acrylonitrile and other chemicals, which are known to the State of California to cause cancer and reproductive harm. For more information go to www.P65Warnings.ca.gov.

Tools for Assembly

Tools Needed:













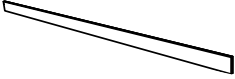

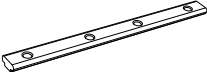
#2 Phillips Screwdriver
Straight Edge

⚠ ATTENTION Do not use power tools for assembly.

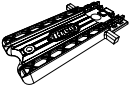
Saw Components

Accu-Cut™ (KMA2700) pièces

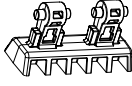
*Part functional only on Kreg Rip-Cut™.

A		2	Tracks	I		2	Base-Plate Clamps
B		4	Guide Strips (Pre-Installed)	J		1	Indexing Stop
C		2	Track Connector Bars	K		3	Machine Screws
D		8	Set Screws	L		3	Hex Nuts
E		1	Starting Block	M		1	Indicator Clip
F		1	Filler Strip	N*		1	Cursor
G		1	Sled	O*		1	Wedge
H		2	Set Screws	P*		1	Handle

Before You Begin

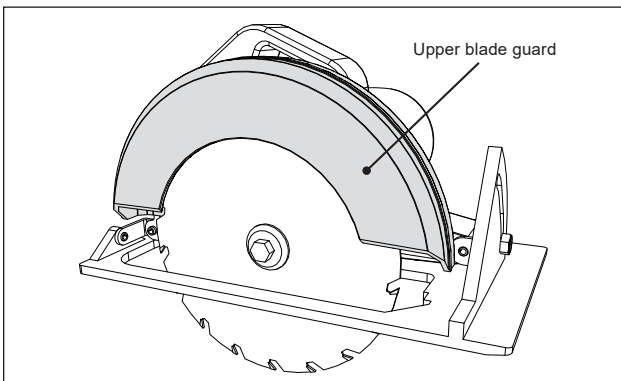

⚠ ATTENTION The Accu-Cut™ is designed for use with portable circular saws that have a metal upper blade guard. When paired with the Accu-Cut, a saw with a plastic upper blade guard may allow deflection between the blade and the base plate resulting in poor cut quality. Do not use a saw with a plastic upper blade guard with the Accu-Cut.

Assembly

Assemble the track

1 Turn the two tracks (A) upside down (black faces of the guide strips up). Slide the track connector bars (C) halfway into the T-slots in the first track at the end with the indicator arrows on the top face and tighten the set screws (D). Slide the second track onto the connector bars so the indicator arrows on the top face align with those on the first track section. Tightly hold the two tracks together and tighten the remaining set screws. A straight edge guide may also be used to ensure alignment, if desired. Slide the starting block (E) into the T-slots at the end of one track.

⚠ ATTENTION Do not overtighten the set screws. Overtightening can cam-out the screw heads or damage the aluminum track.

⚠ ATTENTION The tracks can be taken apart for storage. If you disassemble the tracks, align the indicator arrows on the top faces of the tracks when reassembling them.

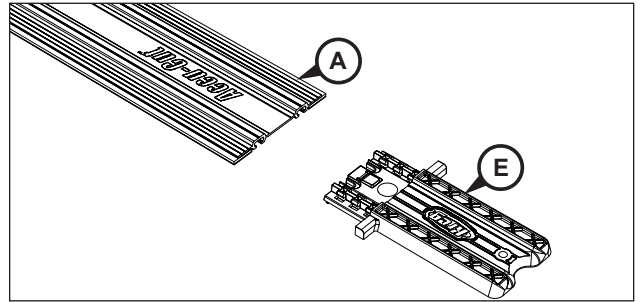
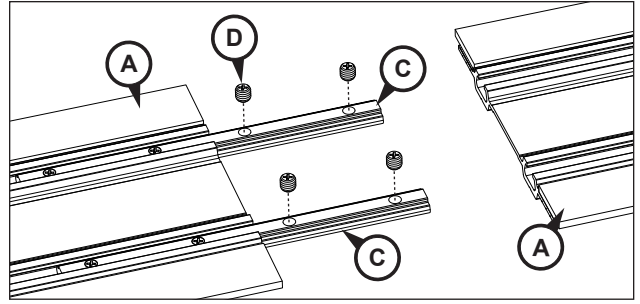

Orient the Filler Strip

2 The filler strip (F) on the sled (G) is shipped with the angled ribs facing up. These ribs support a saw base with an angled leading edge, keeping the saw base flat on the sled when the set screws (H) in the base-plate clamps (I) are tightened. For a saw base with a flat leading edge, lift the filler strip from the sled recess with the tip of a screwdriver, turn it over to expose the flat face, and press it into the recess.

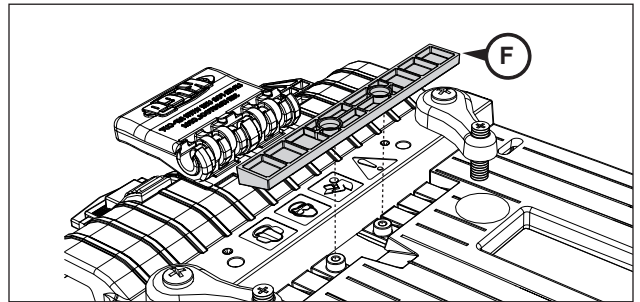
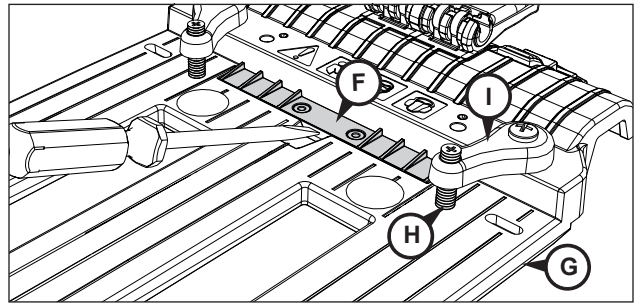

Mount your Circular Saw on the Sled

3 Remove the indexing stop (J) from the sled (G). Loosen the set screws (H) in the base-plate clamps (I) and slide your saw base plate under them. Position the saw on the sled with the front of the saw base plate against the step at the front of the sled. For saws with the blade on the left-hand end of the motor, center the blade in the left sled slot. For saws with the blade on the right-hand end of the motor, center the blade in the right sled slot. To accommodate different saw base-plate configurations, there are two holes for attaching each base-plate clamp to the sled. For the most secure clamping, choose the holes that provide widest spacing allowed by your saw. The clamps can be oriented at an angle. Tighten the set screws onto the saw base plate just enough to hold the saw in place.

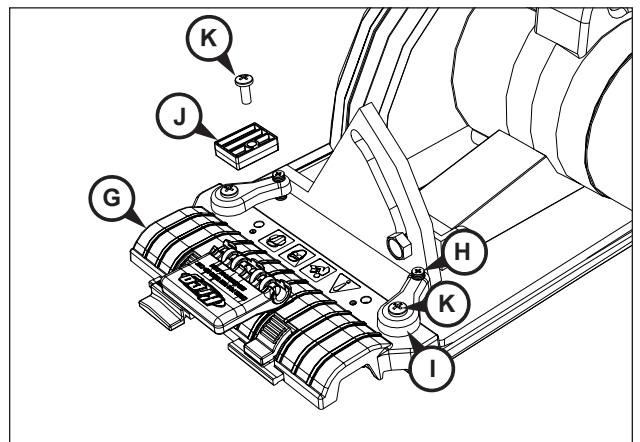

⚠ WARNING Disconnect the saw from power before mounting it on the sled.

Assembly

Align the Saw/Sled Assembly on the Track

4 There are three grooves in the bottom of the sled (**G**). For a saw with the blade in the right-hand sled slot, the center and left grooves ride on the track (**A**) rails. For a saw with the blade in the left-hand sled slot, the center and right grooves ride on the track rails. Position the saw/sled assembly on the starting block, engaging the appropriate sled grooves. Loosen the base-plate clamp (**I**) set screws (**H**) enough to slide the saw side to side. Align the saw so the blade will shave about $\frac{1}{32}$ " [.8mm] off the guide strip. (You'll trim the guide strip later for zero-offset positioning of the track.) Tighten the base-plate clamp set screws enough to securely hold the saw, but do not over tighten. Make sure the saw blade guard operates freely.

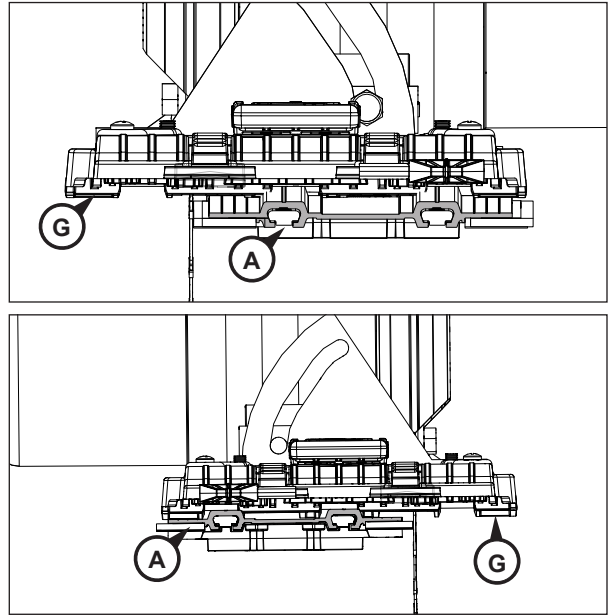

Check the Position of the Indicator Clip and Cursor*

5 There are two positions on the sled for the indicator clip (**M**) and cursor (**N***) that correspond to the two sled slots. Position the cursor in the holder in front of the saw blade and the indicator clip in the other holder. To switch indicator clip and cursor positions, press down on the holder locks, slide the indicator clip and cursor out of the holders and reinstall each one in the other holder. For ease in positioning the saw/sled assembly on the starting block, align the notch at the front of the indicator clip with the groove in the track rail.

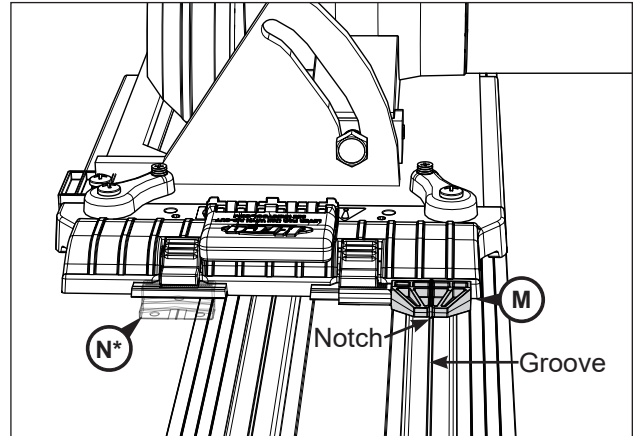

⚠ ATTENTION The sled assembly is equipped with features only functional on the Kreg Rip-Cut™. Additional steps, found in the Rip-Cut™ manual, are required to calibrate this sled for use on the Rip-Cut™.

*The cursor is functional only on the Rip-Cut™.

Reinstall the Indexing Stop

6 The indexing stop (**J**) allows you to remove the saw from the sled assembly and then re-mount it in exactly the same position without having to re-trim the guide strip. Place the indexing stop against the side of the saw base and secure it to the sled with the machine screw (**K**) and nut (**L**). For maximum positioning flexibility, the sled is slotted and the indexing stop can be rotated 180°.

⚠ ATTENTION When mounting a different saw on the sled repeat Steps 2-6. When installing a different blade in the saw, repeat Step 4.

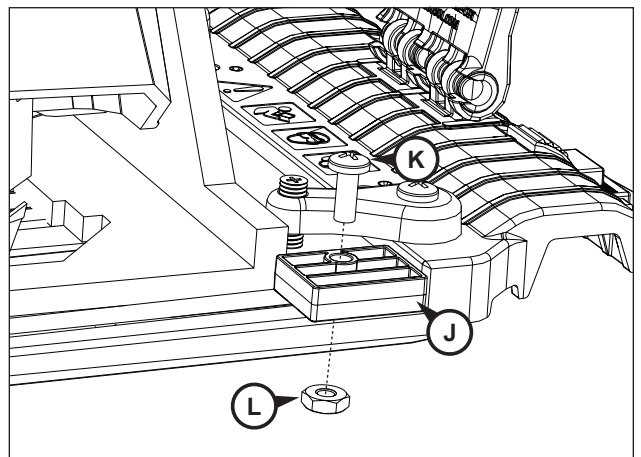

Assembly

Trim the Guide Strip

7 The tracks (A) are supplied with the guide strips (B) already installed. The guide strips grip the workpiece surface to ensure the track does not move during use. When properly trimmed, the guide strips allow you to align the edge of the strip with the cutline and provide zero-clearance support next to the blade to minimize chip-out.

To allow positioning the edge of the guide strip on the workpiece cutline (zero offset), position and fully support the track on a 48" [1219mm]-long scrap workpiece with the edge stop on the bottom of the starting block against the edge of the workpiece. Position the saw/sled assembly on the starting block using the indicator clip to ensure proper alignment and engage the track rails. Adjust the depth of cut so the blade will protrude $\frac{1}{8}$ " [3mm] through the workpiece during the cut. With the blade clear of the workpiece, turn on the saw. Applying light downward pressure on the saw and maintaining a steady, controlled pace, trim the guide strip and workpiece along the entire length of the track. Turn off the saw and allow the blade to stop before removing the saw/sled assembly from the track.

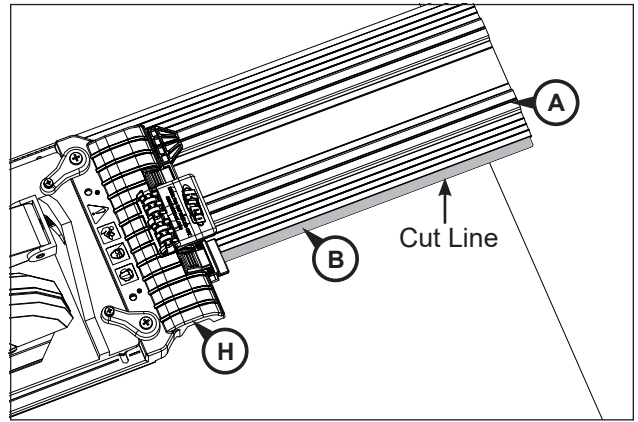

⚠ WARNING The wedge lock is functional only on the Kreg Rip-Cut™. To avoid interference with the operation of the Accu-Cut™, raise the wedge (O*) by pushing the handle (P*) forward and down. Make sure the handle is in this position whenever using the Accu-Cut™.

⚠ ATTENTION Always wipe the guide strips with a damp cloth and remove dust and debris from the workpiece before positioning the track.

⚠ ATTENTION Should the zero-offset guide strip become worn or damaged, remove the starting block from the track and install it on the other end. Perform the trimming operation on the second guide strip. When the guide strips are no longer usable, contact Kreg Customer Service or www.kregtool.com to purchase replacements.

Using your Accu-Cut™

1 For the best results, install a 40-tooth blade on your saw

2 Mark the cutline on your workpiece. Position the track with the edge of the guide strip on the cutline and the starting block edge stop against the edge of the workpiece. Always make cuts with the workpiece under the track and the waste to the outside.

3 Place the saw/sled assembly on the starter block, using the indicator clip to align the sled with the track. Adjust the depth of cut so the blade will protrude $\frac{1}{8}$ " [3mm] through the workpiece during the cut.

4 Connect your saw to power. With both hands on the saw and the blade clear of the workpiece, turn on the saw. Applying light downward pressure on the saw and maintaining a steady, controlled pace, make the cut. Turn off the saw and allow the blade to stop before removing the saw/sled assembly from the track.

⚠ WARNING Completely support the workpiece and cutoff with 2x4s or [2"] [50mm]-thick rigid foam insulation laid flat on the floor.

⚠ WARNING When more than 12" of the end of the track opposite the starter block extends beyond the workpiece, support the protruding end of the track with an auxiliary surface that is flush with the workpiece.

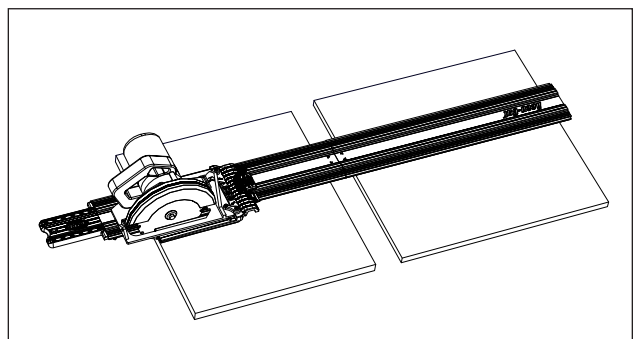
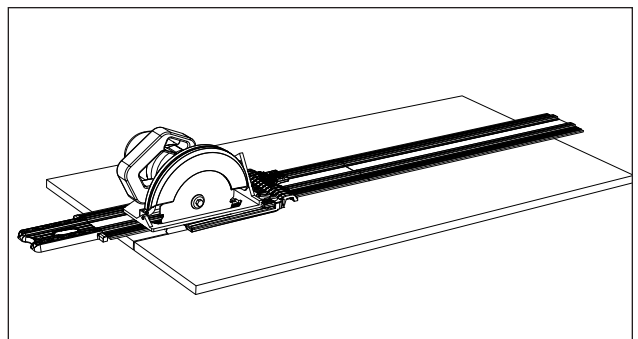
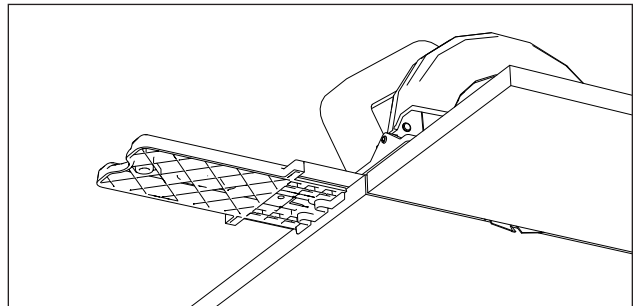

OPTIONAL ACCESSORIES

Kreg Track Clamps *(Sold separately)*

These clamps slide into notches in the starter block and T-slots in the track to allow the track to be clamped to the workpiece. They are recommended when cutting material with a slippery surface, such as melamine-coated particleboard, or when any of these conditions exist: the entire length of the track is not fully supported by the workpiece, the workpiece is not flat, or when making cuts with a single section of track.

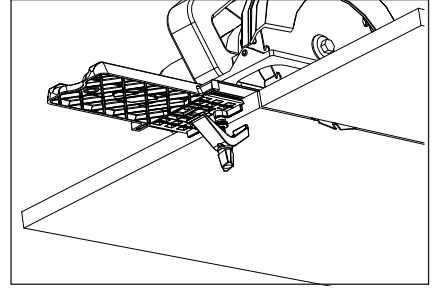
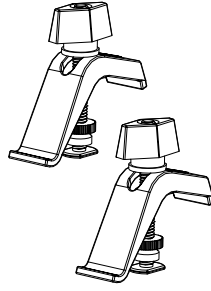

Accu-Cut™ Expansion Pack *(Sold separately)*

Double the cutting capacity of your Accu-Cut™ with the Accu-Cut Expansion Pack. It connects easily to your Accu-Cut to deliver the same straight, accurate, splinter-free performance on cuts up to 100" long. The Expansion Pack includes two additional 26.5" Aluminum Guide Tracks, six steel Track Connector Bars, eight Anti-Chip/Anti-Slip Guide Strips, and instructions for assembly and setup.

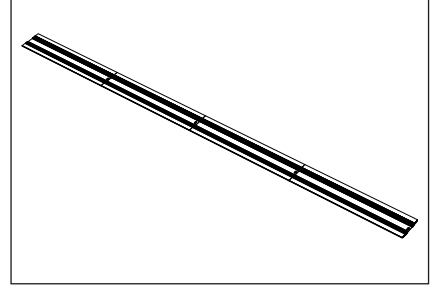
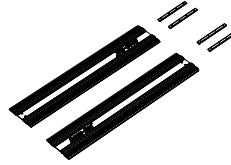

REPLACEMENT PARTS

Guide Strips *(Sold separately)*

Over time, the guide strips can become worn and no longer provide accurate alignment of the track and zero-clearance chip prevention. This package of two guide strips restores the accuracy and cut quality of your Accu-Cut™. You'll need two packs for the Accu-Cut™.

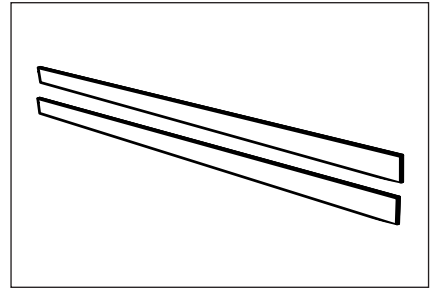

⚠ WARNING Before using the Accu-Cut™, read, understand, and follow the safety warnings and operation instructions included with this product and provided by your saw manufacturer. Keep all tool guards and safety devices in place. Do not attempt a cut when any part of the Accu-Cut™ interferes with the operation of the saw blade guard. Always wear eye and ear protection. Use respiratory protection in dusty conditions. Disconnect the saw from power supply before making any adjustments to the Accu-Cut™ or the saw.