

OWNER'S MANUAL

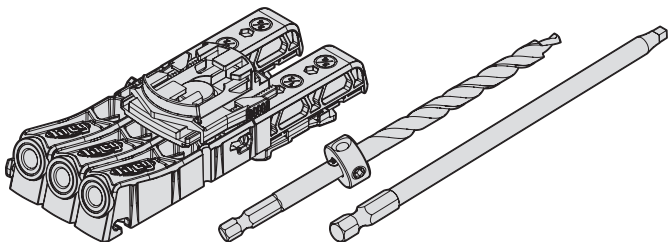

Micro Pocket-Hole Jig

Manual applies to Item # KPHJ230



WARNING Every user must read and follow instructions and safety precautions in this manual. Failure to do so could result in serious injury. Save manual for future reference.

We're here to help.

We want you to have an exceptional project building experience.

If you have questions or need support, please get in touch.

1-800-447-8638 | technicalsupport@kregtool.com

Tell us about your experience.

Your opinion counts. And we're always looking for ways to improve. Share your feedback so we can keep growing and innovating for you. www.kregtool.com/feedback

Table of Contents

Safety Precautions2	Tips	10
Pre-Assembly3	Care and Cleaning	12
Assembly4	Troubleshooting.	12
Operation6	Accessories.	12

Safety Precautions

WARNING Before using an electric tool with this product, read and follow the tool manufacturer's instructions and safety precautions in addition to the safety precautions below to reduce risk of serious injury from hazards such as fire, electric shock, or rotating drill bit.

- Always follow the written safety instructions for using your jig.
- Follow your drill manufacturer's safety guidelines.
- Always wear personal protective equipment certified as such, including safety glasses, hearing and respiratory protection. When using a power tool, always follow the manufacturer's personal protective equipment requirements.
- The drill bit is sharp. Handle with care.
- Do not attempt to hold the jig in place with your hand while drilling. Secure the jig in place with a clamp.
- Do not allow familiarity gained from frequent use of your tools to replace safe work practices. A moment of carelessness is sufficient to cause severe injury.

WARNING Avoid awkward hand positions where a sudden slip could cause contact with the rotating bit.

WARNING Do not operate this tool or any machinery while under the influence of drugs, alcohol, or medications.

WARNING This product can expose you to chemicals including Acrylonitrile and other chemicals, which are known to the State of California to cause cancer and reproductive harm. For more information go to www.P65Warnings.ca.gov.

WARNING Drilling, sawing, sanding, or machining wood products can expose you to wood dust, a substance known to the State of California to cause cancer. Avoid inhaling wood dust or use a dust mask or other safeguards for personal protection. For more information go to www.P65Warnings.ca.gov.

Pre-Assembly

Review this section before you begin. Ensure you have all tools on hand and compare the package with the items listed in the Product Description section. If any item appears missing or lost, do not use this product. Contact Technical Support or return product to place of purchase.

Product Description

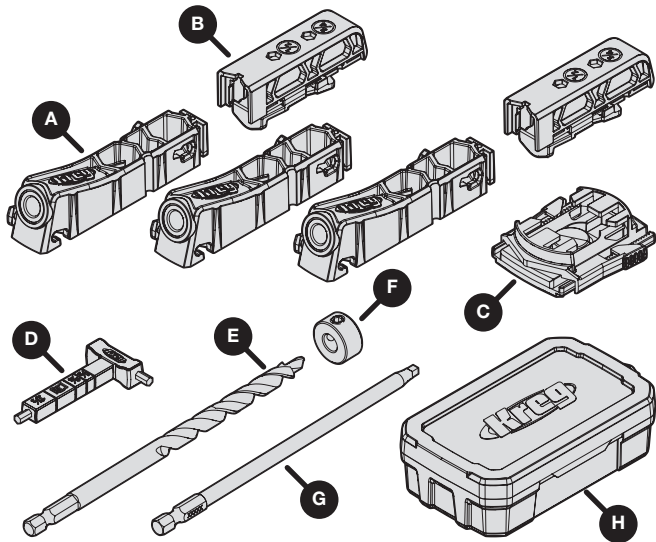

Part	Description
A	Drill guide
B	Material thickness stop
C	Clamp pad adapter
D	Material thickness gauge with hex wrench

Part	Description
E	Easy-set drill bit
F	Easy-set stop collar
G	Driver bit
H	Case

1 Determine the Material Thickness

- a. Use the material thickness gauge (D) to determine the material thickness range.

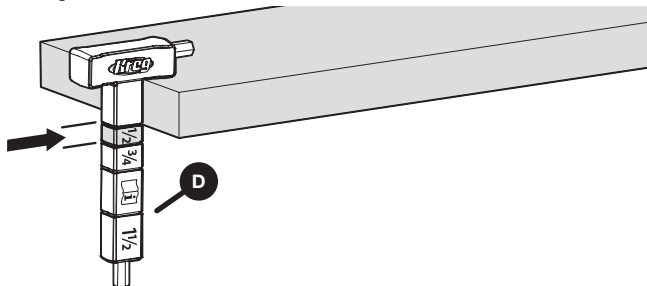

2 Set the Stop Collar

- a. Slide the easy-set stop collar (F) so the desired setting on the drill bit (E) is centered in the easy-set stop collar window.
- b. Tighten the easy-set stop collar (F) with the hex wrench (D).

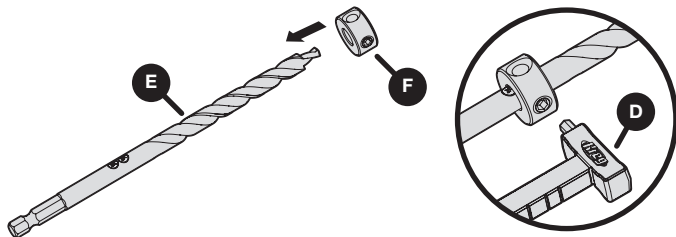

3 Position the Material Thickness Stop

- Push and slide the material thickness stop (B) to the desired setting.

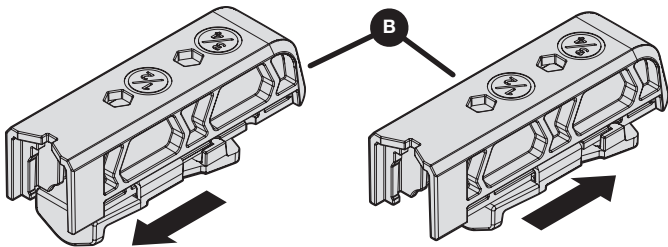

4 Configure the Jig

- Insert and rotate the drill guide (A) into the other drill guide.
- Slide the drill guide forward to join.

Note To remove, pull back and rotate the drill guide to separate.

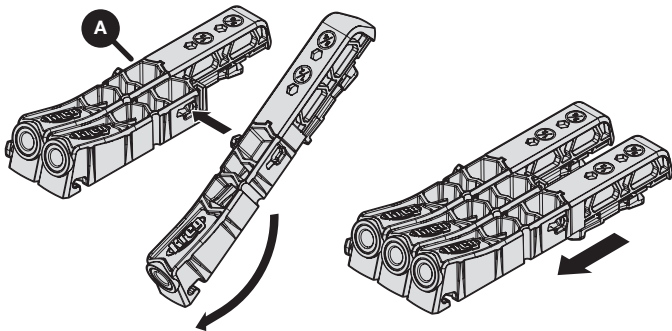

5 Clamp the Jig and Drill the Holes

- Align the material thickness stop (B) to the edge of the workpiece (1).
- Clamp the jig to the piece.

Note Do not block the chip ejection hole (2).

- Drill the pocket hole.

Tip Place pocket holes at the recommended distance from edge (X) of the workpiece. See next section for recommendations.

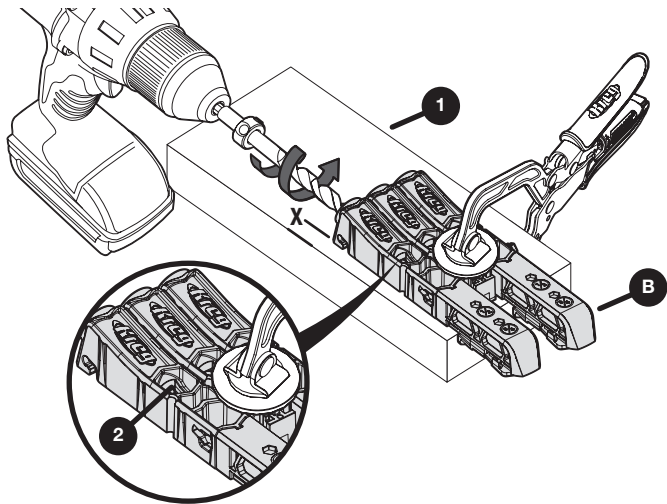

Tip If you cannot use a clamp, secure the jig with screws in the screw recesses.

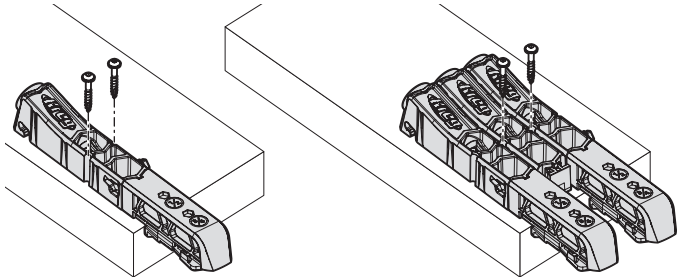

Recommended Hole Spacing Configurations

Narrow Pieces

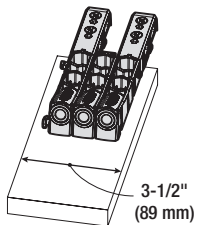
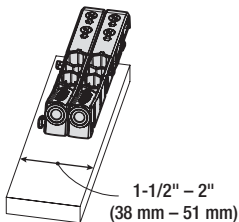

Wide Pieces

Place pocket holes 5/8" to 1-1/2 in. from edge, then every 6-8 in.

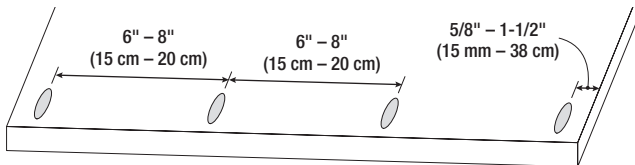

6 Clamp the Joint in Place

Note Clamping secures the workpieces and gives you a better finished joint.

a. Clamp here for the face joint.

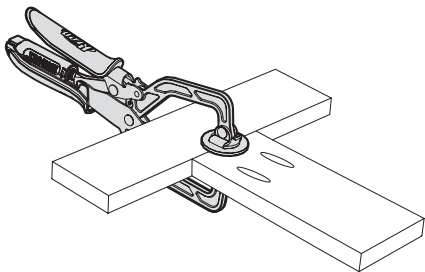

b. Clamp here for the edge joint.

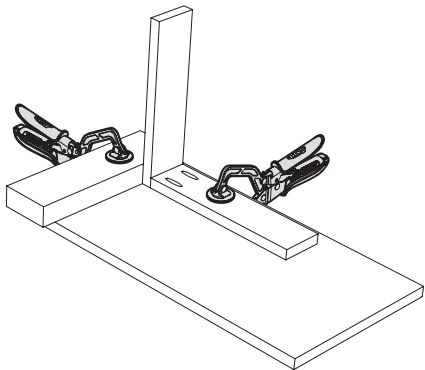

7 Drive the Screws

- Place a screw on the driver bit (G).
- Position the screw in the pilot hole.
- Drive the screw until fully seated without over driving the screw.

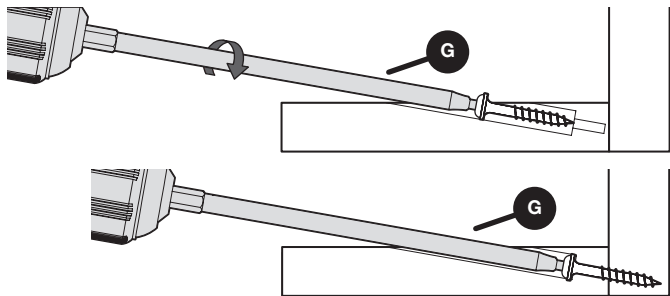

Set-Up and Screw Length Chart For Kreg Screws

Material Thickness	Easy-Set Stop Collar	Material Thickness Stop	Screw Length
1/2"	1/2"	1/2"	3/4" (19 mm)
3/4"	3/4"	3/4"	1-1/4" (32 mm)

Note Use only SPS style head screws.

Note The recommended screw length is 3/4" (19 mm), but in some slightly thicker materials a 1" (25 mm) screw could be used for increased holding power.

To learn more about selecting and purchasing Kreg Screws, visit: www.kregtool.com/screws.

Using the Clamp Pad Adapter

The clamp pad adapter connects the jig to the clamp.

- Position the clamp in the adapter (C) and slide closed.
- Seat the rubber anchor of the adapter (C) in the drill guide (A) as indicated in section view below.

Note Do not block the chip ejection hole (2).

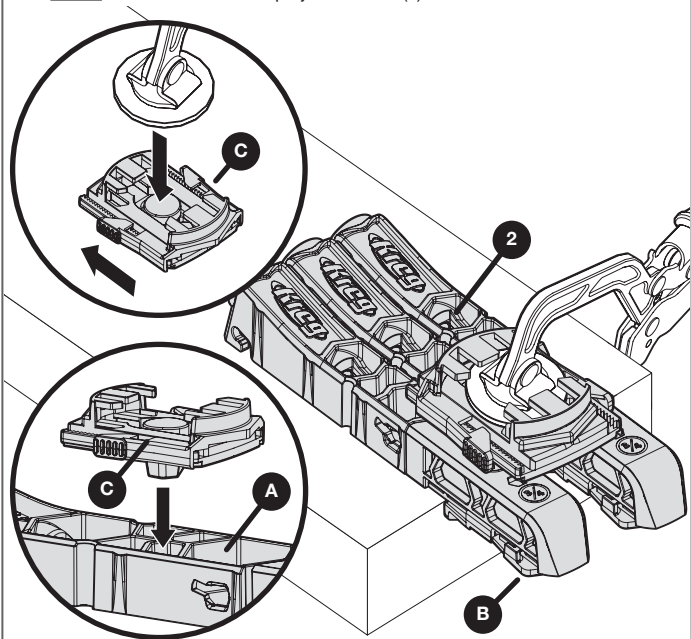

Using the Jig for Repair Applications

- Remove the material thickness stop (B).
- Position the jig on the workpiece.
- Clamp and drill the pocket-holes.

Note The position of the stop collar on the drill bit does not change.

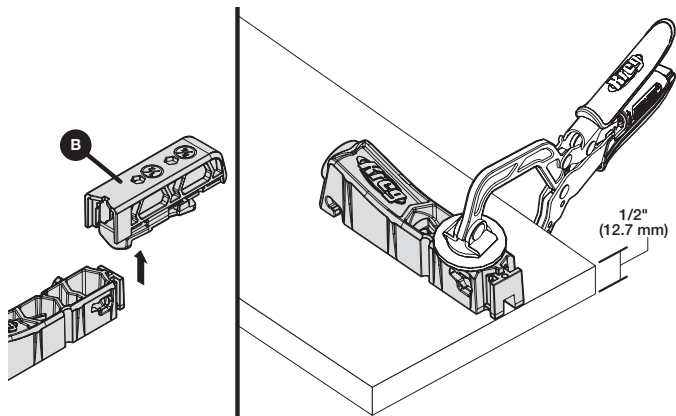

Care and Cleaning

To clean, remove any wood chips and wipe clean with a soft, damp cloth.

Troubleshooting

Contact Technical Support or see the website for FAQs.

Accessories

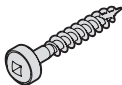

Kreg 3/4" Zinc Pocket-Hole screw
#(SPS-F075-100)

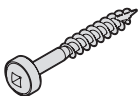

Kreg 1" Zinc Pocket-Hole Screws
#(SPS-F1-100,
#SPS-C1-100)

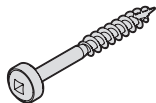

Kreg 1-1/4" Zinc Pocket-Hole Screws
#(SPS-F125-100,
#SPS-C125-100)

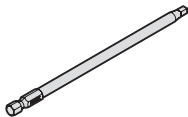

Kreg Square Driver Bit
(#D6)

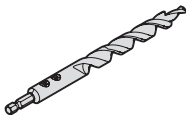

Kreg Micro Easy-set
Drill Bit
(#KPHA540)

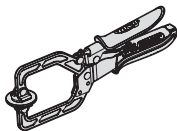

Kreg Wood
Project Clamp
(#KHC3)



EXPLORE. BUILD. SHARE.

We're makers just like you.

That's why we love to see what you're working on.

Share with the community and get inspired!

#madewithKreg

Get free plans, project resources, and more.

kregtool.com and buildsomething.com