

(D)	Originalbetriebsanleitung - Dübelfräse	6
(GB)	Original operating manual - Dowel jointer	12
(F)	Notice d'utilisation d'origine - Fraise à tourillon	17
(E)	Manual de instrucciones original - Fresadora de clavija	23
(I)	Istruzioni per l'uso originali - Fresatrice per tasselli	29
(NL)	Originele gebruiksaanwijzing - Deuvelfrees	35
(S)	Originalbruksanvisning - Pluggfräs	41
(FIN)	Alkuperäiset käyttöohjeet - Liitosjyrsin	46
(DK)	Original brugsanvisning - Dyvelfræser	51
(N)	Originalbruksanvisning - Pluggfres	56
(P)	Manual de instruções original - Fresa para buchas	61
(RUS)	Оригинал Руководства по эксплуатации - Фрезер для дюбельных соединений	67
(CZ)	Originál návodu k obsluze - Kolíkovací fréza	73
(PL)	Oryginalna instrukcja eksploatacji - Frezarka do kotków płaskich	78

## DOMINO DF 500 Q

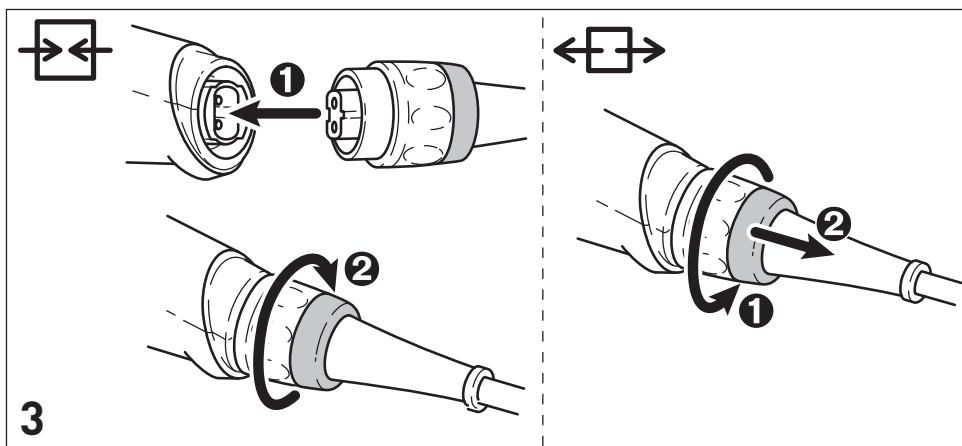

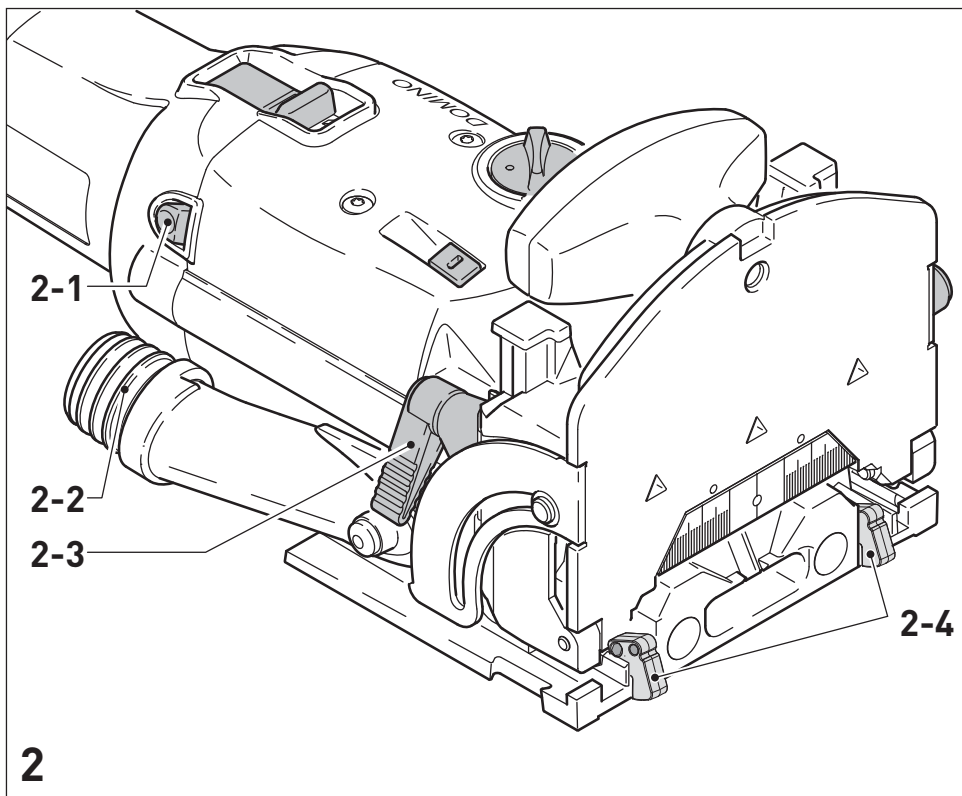

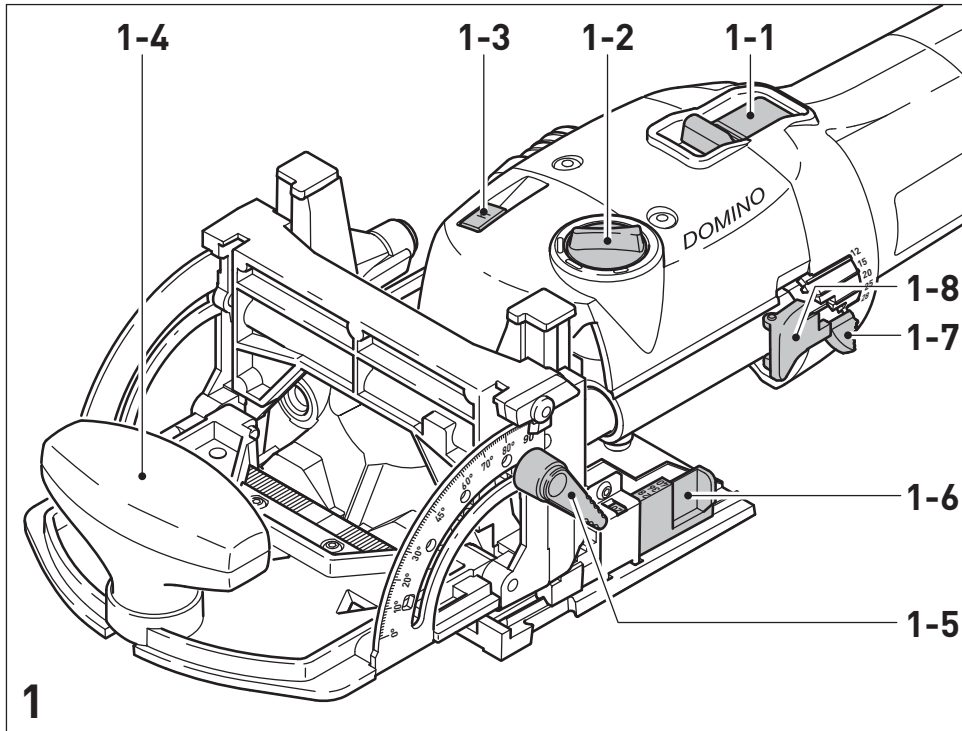
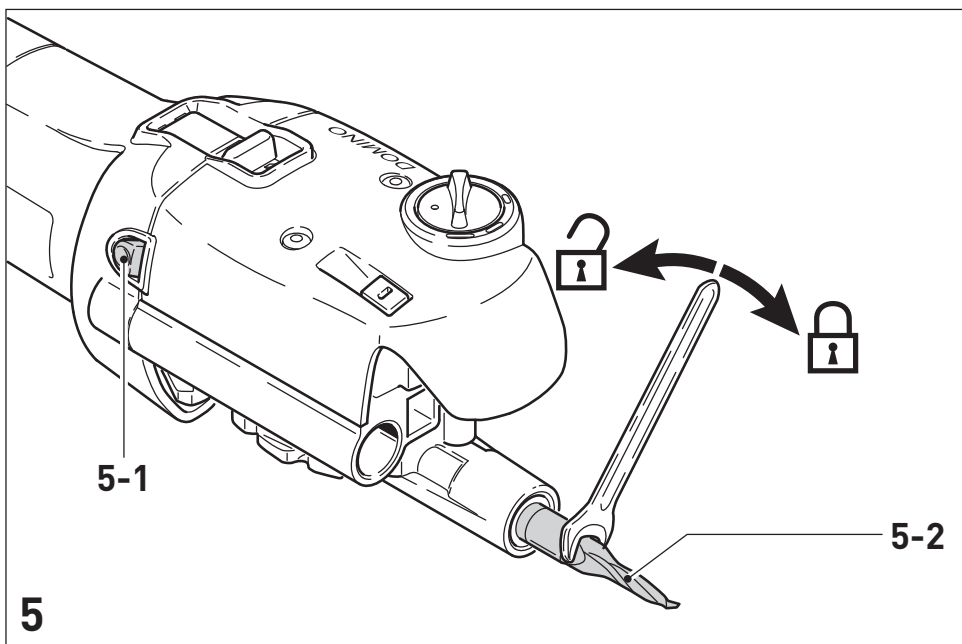
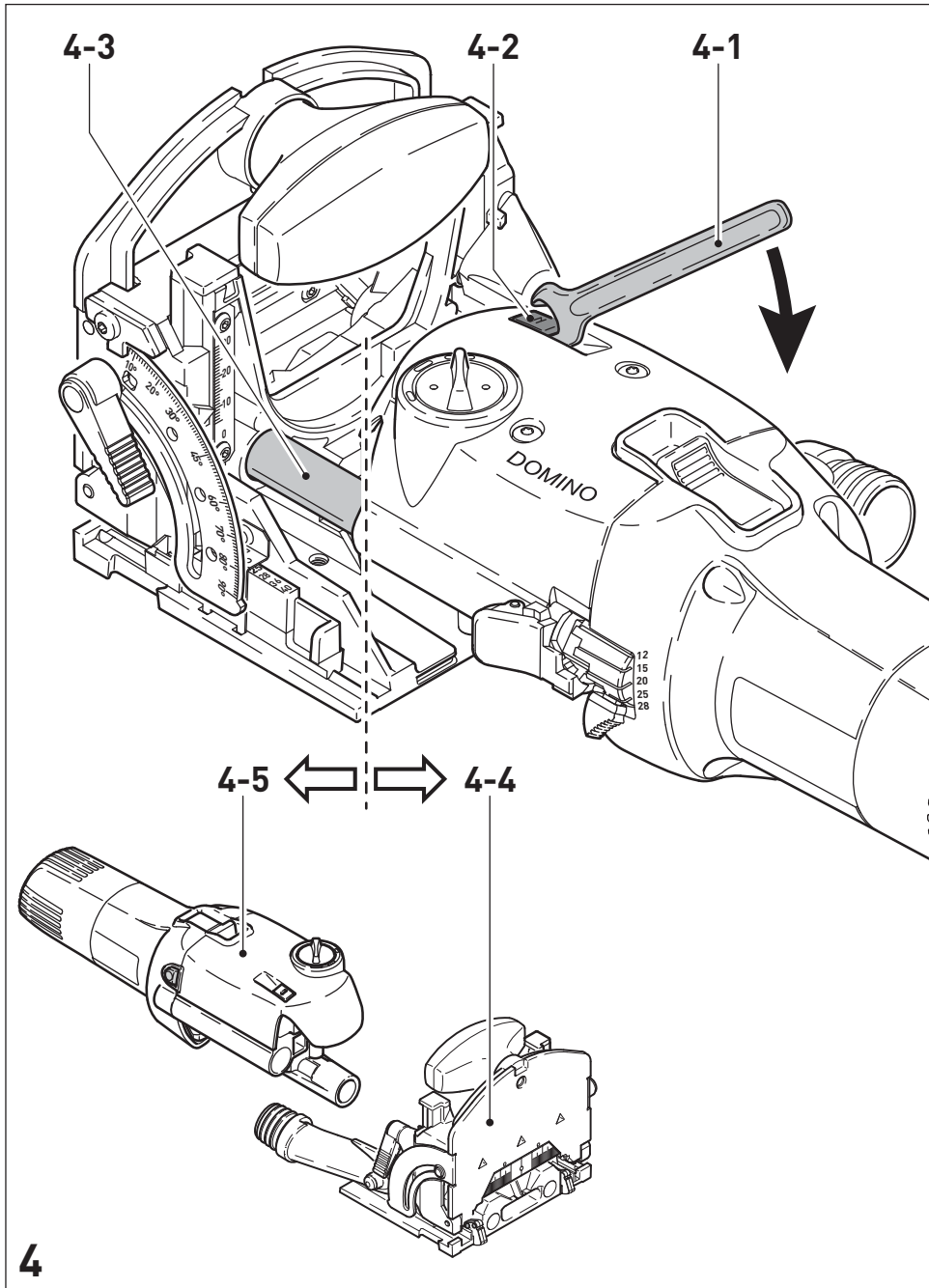

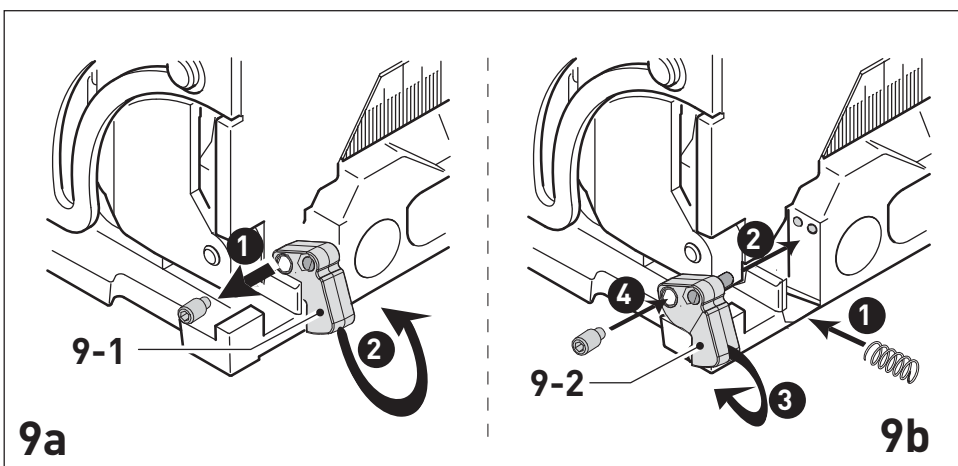
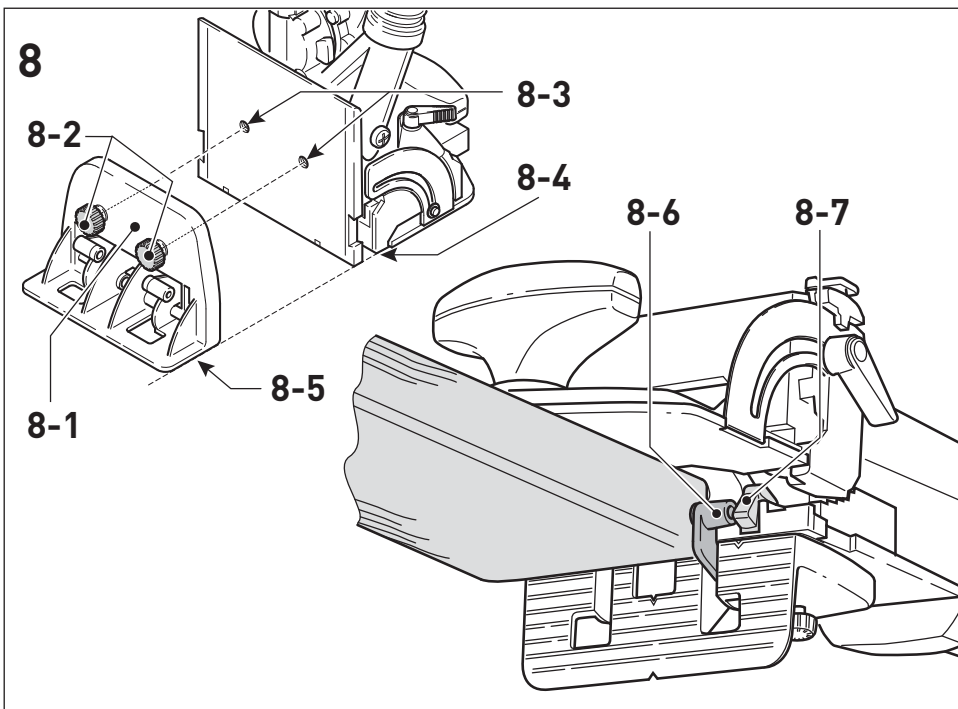
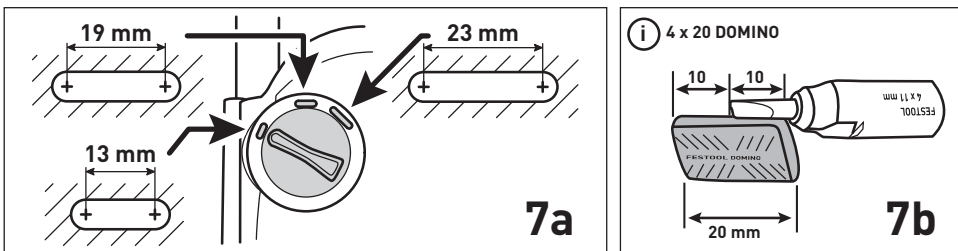
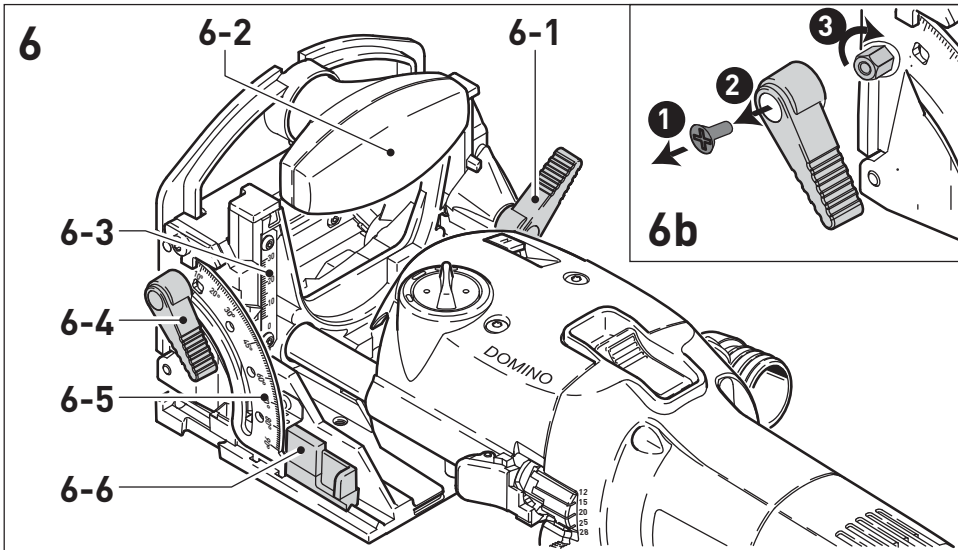

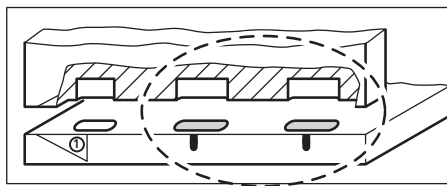
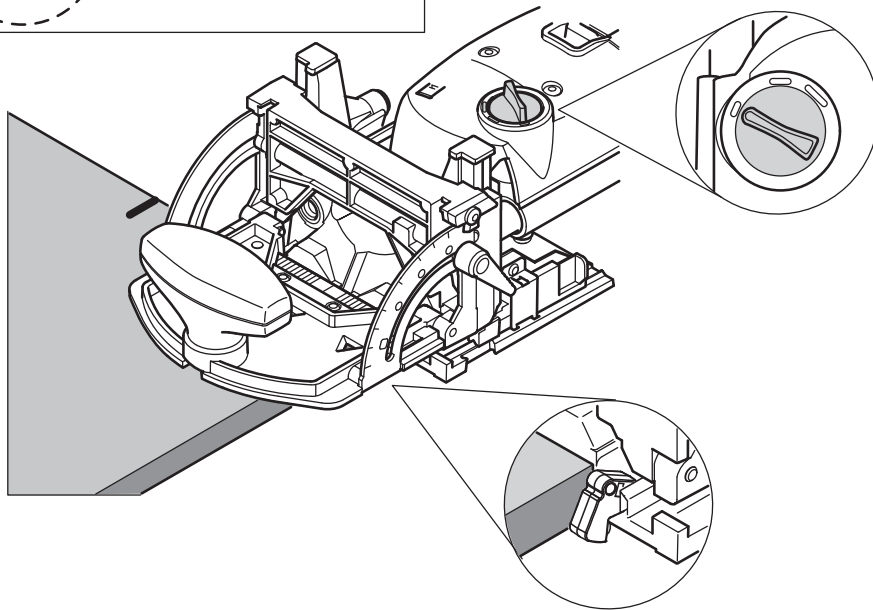
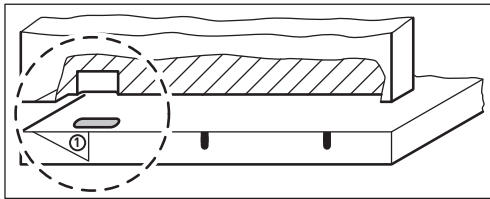
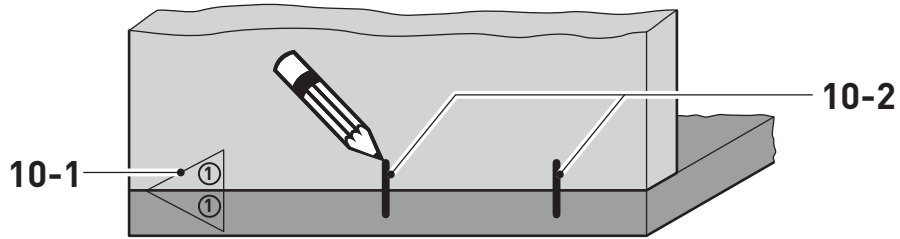

10-3

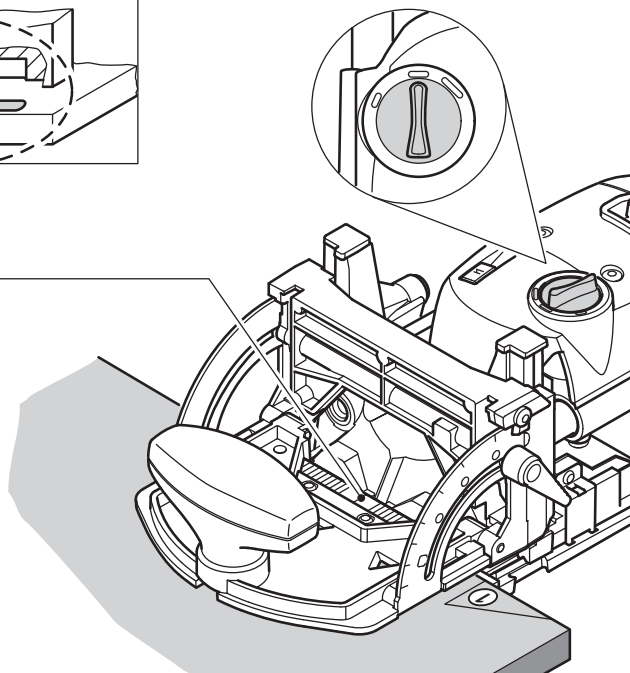

## Dowel jointer

### Table of contents

1	Machine features .....	12
2	Technical data .....	12
3	Pictograms.....	12
4	Intended use .....	12
5	Safety instructions.....	12
6	Power supply and start-up .....	13
7	Machine settings.....	13
8	Working with the machine.....	14
9	Maintenance and care .....	15
10	Accessories, tools.....	15
11	Environment.....	15
12	Example applications.....	16
13	Fault correction .....	16

### 1 Machine features



- [1-1] ON/OFF switch
- [1-2] Rotary switch for Domino dowel-hole width
- [1-3] Unlocking device for motor unit / guide frame
- [1-4] Auxiliary handle
- [1-5] Clamping lever for angle guide
- [1-6] Selection slide for material thickness
- [1-7] Notch lever for Domino dowel-hole depth
- [1-8] Notch lever lock
- [2-1] Spindle lock
- [2-2] Extraction nozzle
- [2-3] Clamping lever for jointing height adjustment
- [2-4] Stop latch

The specified illustrations can be found at the beginning of the operating instructions.

### 2 Technical data

Power	420 W
Speed (no load)	25 500 min <sup>-1</sup>
Jointing depth, max.	28 mm
Jointing width, max.	23 mm + jointer bit diameter
Jointing bit diameter, max.	10 mm
Connecting thread of drive shaft	M6 x 0.75
Weight (excluding cable)	3.2 kg
Degree of protection	□ / II

### 3 Pictograms

-  Note, Danger!
-  Wear ear protection!
-  Wear protective goggles!



Manual, read the instructions.



Wear a protective mask!



CE marking: Confirms the conformity of the power tool with the European Community directives.



UKCA marking: The United Kingdom Conformity Assessed symbol is a marking for products being placed on the market in the United Kingdom. It is a manufacturer's indication that the product is in conformance with the relevant regulations in the UK.

### 4 Intended use

The Domino dowel jointer is designed to produce Domino dowelled joints in soft and hard wood, chip board, plywood and fibre boards. All applications beyond this are regarded as unspecified use. The Domino dowel jointer is designed and approved for use by trained persons or specialists.



The user is liable for damage and injury resulting from incorrect usage!

### 5 Safety instructions

#### 5.1 General Safety Rules



**WARNING! Read all safety warnings and all instructions.**

Failure to follow the warnings and instructions may result in electric shock, fire and/or serious injury.

**Save all warnings and instructions for future reference.**

The term „power tool“ in the warnings refers to your mains-operated (corded) power tool or battery-operated (cordless) power tool.

#### 5.2 Tool-specific safety rules

- **Mounting tools must be rated for at least the speed marked on the tool.** Mounting tools running over rated speed can fly apart and cause injury.
- **Always use the guard.** The guard protects the operator from broken mounting tool fragments and unintentional contact with the mounting tool.
- **Hold power tool by insulated gripping surfaces, because the cutter may contact its own cord.** Cutting a “live” wire may make exposed metal parts of the power tool “live” and could give the operator an electric shock.
- **The DF 500 Q must only be fitted with the jointer bits offered by Festool for this purpose.** The

use of other jointer bits is prohibited due to the increased risk of injury.

- **Never work with blunt or damaged jointer bits.** Blunt or damaged jointer bits can lead to a loss of control of the power tool.
- **When the motor unit is released, it must move back actuated by spring force so that the jointer bit disappears completely in the protective cover.** If this does not happen, the machine must be switched off immediately and repaired before reuse.
- **Only for AS/NZS:** The tool shall always be supplied via residual current device with a rated residual current of 30 mA or less.



To protect your health, wear a P2 protective mask.

### 5.3 Noise and vibration information

The typical values determined in accordance with EN 60745 are:

Sound-pressure level	84 dB(A)
Sound-power level	95 dB(A)
Measuring uncertainty allowance	K = 3 dB



Wear ear protection!

Vibration emission value  $a_n$  (vector sum for three directions) and uncertainty K measured in accordance with EN 60745:

Vibration emission value	$a_n = 3,0 \text{ m/s}^2$
	$K = 1,5 \text{ m/s}^2$

The specified emissions values (vibration, noise) – are used to compare machines.

- They are also used for making preliminary estimates regarding vibration and noise loads during operation.
- They represent the primary applications of the power tool.

Increase possible for other applications, with other insertion tools or if not maintained adequately. Take note of idling and downtimes of machine!

## 6 Power supply and start-up



The mains voltage must correspond to the specification on the rating plate.



Always switch the machine off before connecting or disconnecting the mains lead!

See **Fig. 2** for connection and disconnection of the power cable.

To switch on, push the switch **[1-1]** forwards until it engages. Pressing the back end of the switch is sufficient to release the switch-on lock and switch the machine off.

## 7 Machine settings



Always remove the power supply plug from the socket before carrying out any work on the machine.

### 7.1 Changing tools

Required tools: fork wrench a/f 8 (supplied).



Always wear protective gloves during tool change due to the risk of injury from the sharp tool cutters.

#### a) Removing the tool

- Lift the unlocking lever **[4-2]** until it audibly engages with the fork wrench **[4-1]**.
- Separate the motor unit **[4-5]** and the guide frame **[4-4]**.
- Press and hold in the spindle lock **[5-1]**.
- Release and unscrew the jointer bit **[5-2]** with the fork wrench.
- Release the spindle lock.

#### b) Inserting the tool

- Before inserting a new jointer bit, ensure that the machine, the guide frame and the guides **[4-3]** are clean. Remove any contamination that may be present. Only use sharp, undamaged and clean tools.
- Press and hold in the spindle lock **[5-1]**.
- Use the fork wrench to screw on the jointer bit **[5-2]**.
- Release the spindle lock.
- Slide the guide frame onto the motor unit until it audibly engages.

### 7.2 Adjusting the milling depth

- Open the notch lever lock **[1-8]** by pressing it.
- Use the locking lever **[1-7]** to set the desired jointing depth (12 mm, 15 mm, 20 mm, 25 mm, 28 mm). For the jointer bit with a diameter of 5 mm, only jointing depths of 12 mm, 15 mm and 20 mm are permitted due to its short shank length.
- Release the notch lever lock again.

A special cutter is available for the DOMINO dowel 4x20 mm (due to risk of breakage). **Note the following** when using this cutter (D 4-NL 11 HW-DF 500):

- Set the routing depth to 20 mm using the stop lever **[1-7]**. The actual routing depth is 10 mm. The dowel can only be positioned centrally (see **Fig. 7b**).



Ensure that the jointing depth is at least 3 mm smaller than the workpiece thickness. Otherwise the jointer bit can emerge from the workpiece at the rear side, which involves an increased risk of injury.

### 7.3 Setting jointing height

#### a) with selection slide

- Release the clamping lever **[6-1]** for jointing height adjustment.
- Using the additional handle **[6-2]**, raise the front section of the guide frame.
- Use the slide **[6-6]** to set the desired board thickness (16 mm, 20 mm, 22 mm, 25 mm, 28 mm, 36 mm, 40 mm).
- Press the front section of the guide frame downwards as far as the stop.
- Close the clamping lever **[6-1]**.

#### b) freely selectable

- Release the clamping lever **[6-1]** for jointing height adjustment.
- Using the additional handle **[6-2]**, raise the front section of the guide frame.
- Push the slide **[6-6]** to the stop in direction motor unit.
- Set the desired jointing height using the scale **[6-3]** by moving the front section of the guide frame vertically.
- Close the clamping lever **[6-1]**.

### 7.4 Setting angle guide

- Release the clamping lever for the angle guide **[6-4]**.
- Set the desired angle: using the scale **[6-5]** steplessly from 0° - 90°, or in notches at 0°, 22.5°, 45°, 67.5°, 90°.
- Close the clamping lever **[6-4]**.

### Mitre cutting thin workpieces

- Set the desired angle.
- Release the clamping lever **[6-1]** for jointing height adjustment.
- Push the slide **[6-6]** to the stop in direction motor unit.
- Slide the angle stop all the way down.
- Close the clamping lever **[6-1]**.



Always release the clamp lever **[6-1]** before resetting the angle stop.

### 7.5 Setting dowel-hole width



Reliable setting of the dowel-hole width with the rotary switch **[1-2]** is only possible with the machine running!

The following dowel-hole settings are possible (**Fig. 7a**):

- 13 mm + jointer bit diameter
- 19 mm + jointer bit diameter
- 23 mm + jointer bit diameter

### 7.6 Dust extraction



Always connect the machine to a dust extractor. You can connect a Festool extractor with an extractor hose diameter of 27 mm to the extractor connector **[2-2]**.

### 7.7 Additional stop with extension

The additional stop **[8-1]** can be used to enlarge the contact surface when jointing on the workpiece edge, thus allowing safer guidance of the machine.

The distance to the centre of the routed hole can be reduced from 37 mm to 20 mm using the two integral stop spacers **[8-6]**, allowing you to position the dowel closer to the edge.

- Secure the additional stop to the threaded bores **[8-3]** on the guide frame using both screws **[8-2]**, whereby the contact areas of the support ring **[8-5]** and the table **[8-4]** must be level with one another.
- Swivel one of the distance spacers **[8-6]** outwards to reduce the distance (see **Fig. 8**). The spacer aligns automatically with the stop latch **[8-7]**.

## 8 Working with the machine

Wood is a natural, non-homogenous material and because of this, its dimensions will most likely deviate slightly during processing, even if the machine is set accurately. Machine handling also influence the degree of working accuracy (e.g. fast-feed speed). Furthermore, the dimensions of wooden DOMINOs may vary (for example, due to humidity), regardless of how they are stored. All of these factors influence the dimensional accuracy of manufactured dowel holes and dowelling joints. Numerous tests have been run to produce an average figure for these dimensional discrepancies. The dimensions of the machine and DOMINO dowels are based on these averages. If a lateral offset of approx. 0.03 mm - 0.04 mm occurs when two workpieces are joined together, you have the option of replacing the stop latches **[2-4]** fitted on delivery with correction stop latches. These latches are 0.15 mm narrower and reduce the lateral clearance of the dowel holes in relation the edge of the workpiece (see Chapter 14).



Prior to processing the final workpiece, it is advisable to optimise the dowel-hole depth, width and diameter using a sample workpiece.



### Please observe the following rules when working:

- Always secure the workpiece in such a manner that it cannot move while being sawed.
- Always hold the Domino dowel jointer with both hands at the motor housing and at the additional handle. This reduces the risk of injury and is a prerequisite for precise work.
- Close the clamping lever for jointing height adjustment [2-3] and the clamping lever for the angle guide [1-5] so that accidental release during operation is impossible.
- Adapt the feed rate to the jointer bit diameter and material. Work with a constant feed rate.
- Only lay the Domino dowel jointer aside when the jointer bit has come to a complete standstill.
- Use the machine only with the guide frame mounted.

### Procedure

Proceed as follows to create a dowelled joint:

- Select a Domino dowel and insert a matching jointing bit in the Domino dowel jointer (Chap. 7.1).
- Set the jointing depth (Chap. 7.2). The jointing depth must be at least 3 mm smaller than the workpiece thickness so that the dowelled joint is supportable.
- Set the jointing height to correspond to the workpiece thickness (Chap. 7.3).
- Mark the areas on the workpiece that belong together [10-1] so that you will be able to join them correctly again once you have cut the dowel holes.
- Position the two workpieces to be joined against one another and mark the desired positions of the dowels with a pencil [10-2].
- Set the desired dowel-hole width (Chap. 7.5).

**Our recommendation:** Cut the first hole without play (dowel-hole width = Domino dowel width), and the remaining dowel holes to the next largest dowel-hole width (Fig. 10). The first dowel hole therefore serves as a reference dimension, whereas the remaining dowel holes have tolerance for manufacturing inaccuracies.

- Cut the dowel holes:
  - a) the first dowel hole by placing the stop latch at the side edge of the workpiece,

- b) the following dowel holes according to the pencil markings made beforehand and the scale of the viewing window [10-3].

## 9

### Maintenance and care



Always remove the power supply plug from the socket before carrying out any work on the machine.



All maintenance and repair work which requires the motor casing to be opened may only be carried out by an authorised service centre.



**Customer service and repair.** Only through manufacturer or service workshops: Please find the nearest address at: [www.festool.com/Service](http://www.festool.com/Service)



Use only original Festool spare parts! Order No. at: [www.festool.com/Service](http://www.festool.com/Service)

The Domino dowel jointer is to a large extent maintenance-free. However, we recommend an annual inspection and/or a check after approx. 100 operating hours at an authorised customer service workshop. This is for the safety of the user and the value stability of the Domino dowel jointer. Always keep the machine and the ventilation slots clean.

Dust deposits must be removed from the guides [4-3]. Oil the guides regularly and lightly with resin-free oil (e.g. sewing machine oil).

### To secure the clamp lever (see Fig. 6b):

- Remove the clamp lever and tighten the hexagon screw.
- Attach the clamp lever to the hexagon screw again.

The tool is fitted with special motor brushes with an automatic cut-out. When the brushes become worn the power supply is shut off automatically and the tool comes to a standstill.

## 10

### Accessories, tools



For your own safety, use only original Festool accessories and spare parts.

Festool offers extensive accessories that enable you to use your machine effectively for a wide variety of applications, e.g.: routing circle, guide rails with rows of holes, routing aid, router base for bench-mounted use.

The accessory and tool order number can be found in the Festool catalogue or on the Internet under „[www.festool.com](http://www.festool.com)“.