



MM 500 Plus ()**

7 129 ...

MM 500 Plus (**)

7 229 ...

P_1	W	350
P_2	W	190
n_S	/min, min ⁻¹ , rpm, r/min	10 000 – 19 500
	°	2 x 1,7
	kg	1,45
L_{pA}	dB	72,0
K_{pA}	dB	3,0
L_{wA}	dB	83,0
K_{wA}	dB	3,0
L_{pCpeak}	dB	84,0
K_{pCpeak}	dB	3,0



3

de	9	pt	35	tr	60	sl	87	et	114	th	139
en	13	el	39	hu	64	sr	91	lt	118	ja	144
fr	17	da	44	cs	69	hr	95	lv	122	hi	148
it	21	no	48	sk	73	ru	99	zh(CM)	126	ar	156
nl	25	sv	52	pl	78	uk	104	zh(CK)	131		
es	30	fi	56	ro	83	bg	109	ko	135		

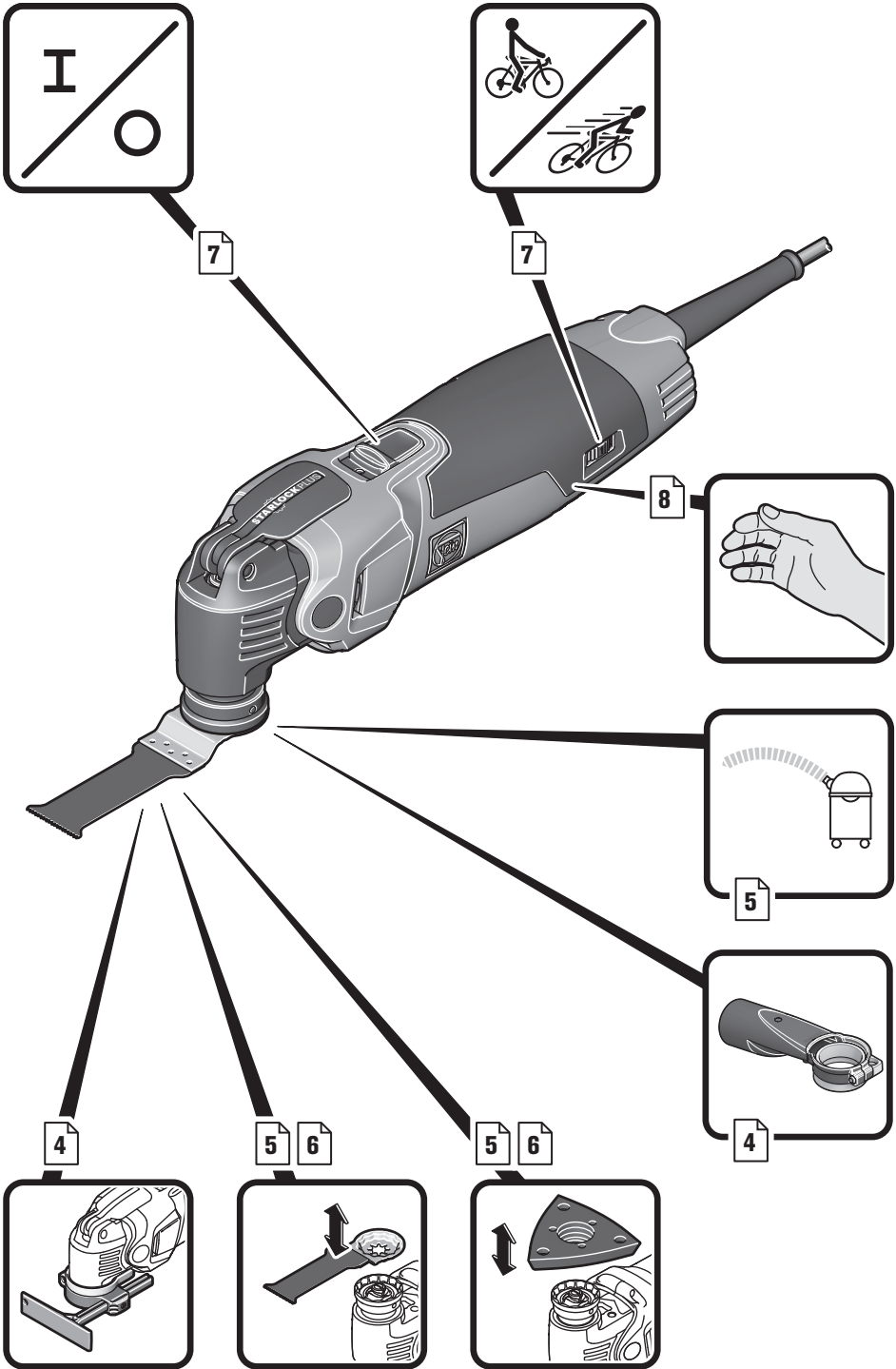

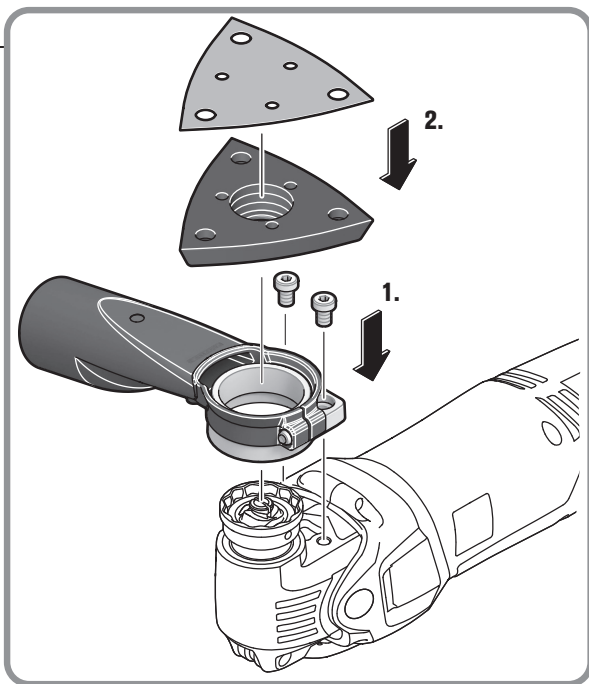
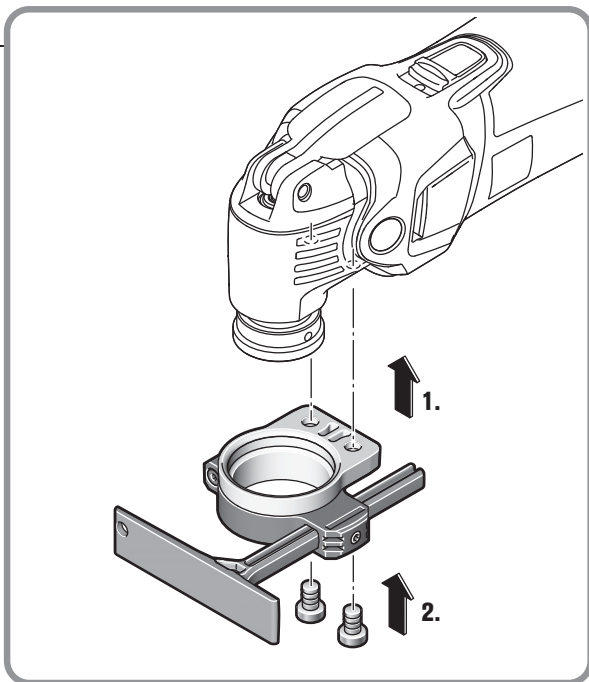
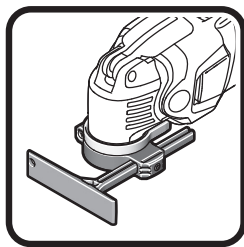

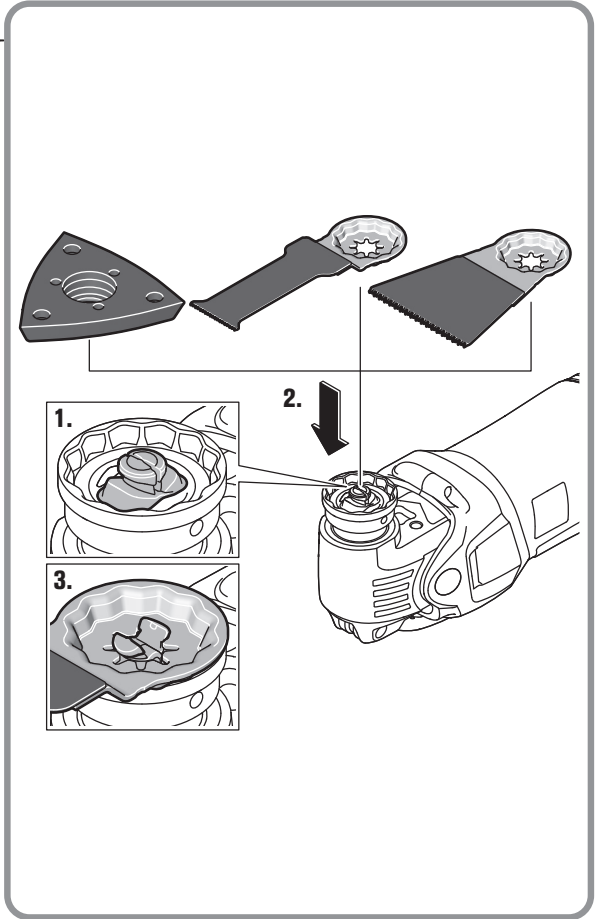
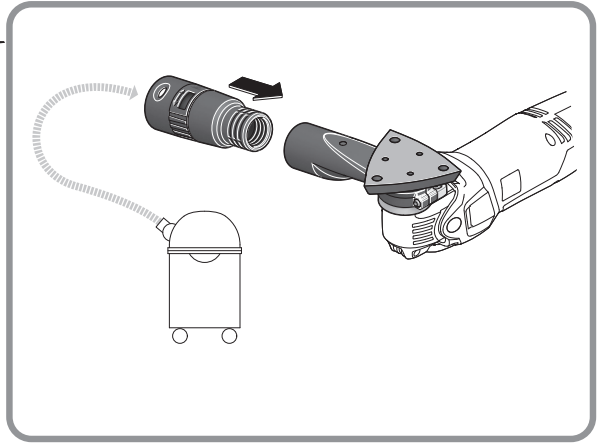

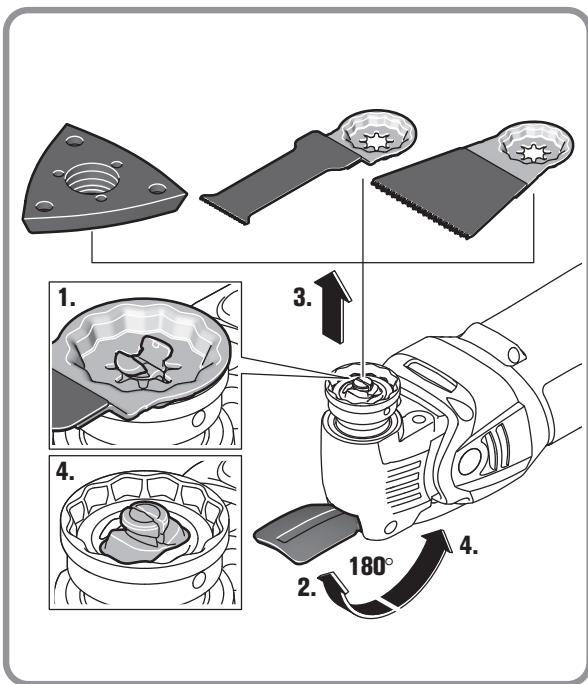
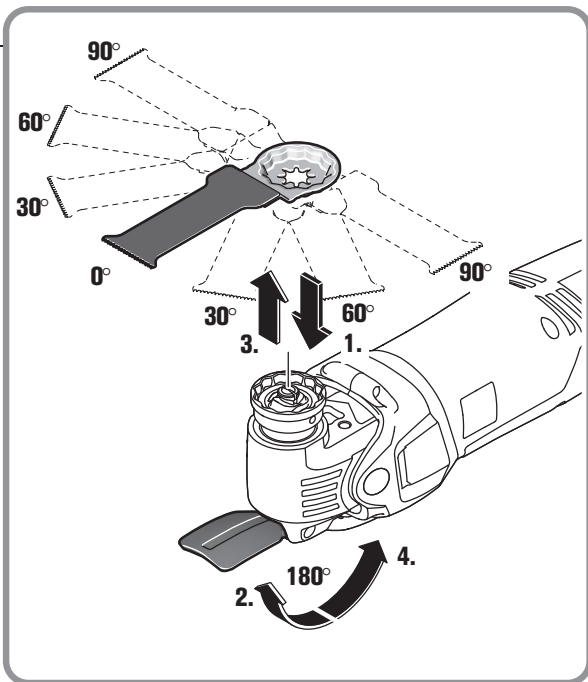

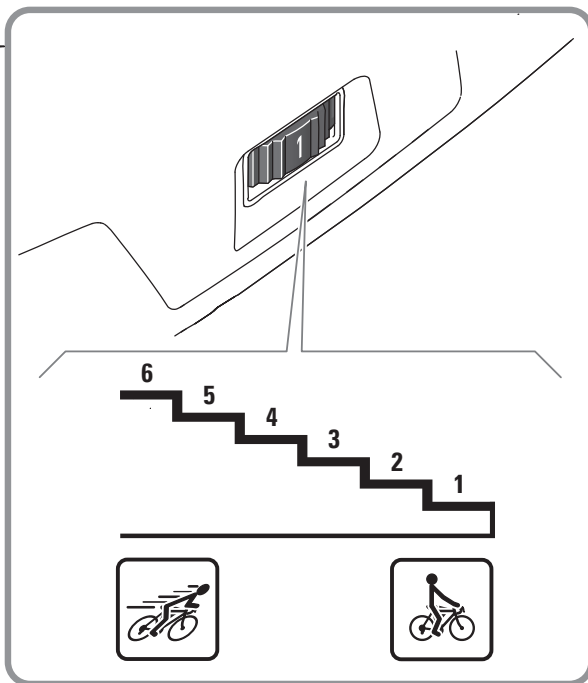
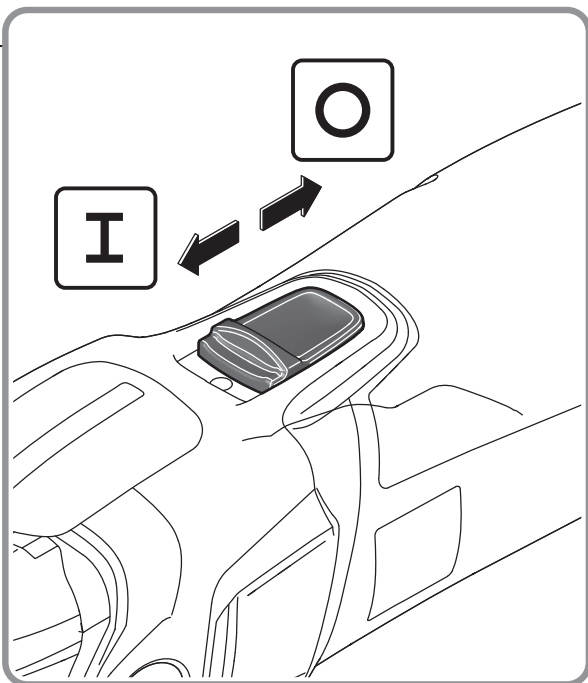
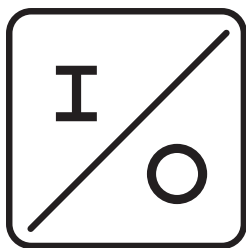

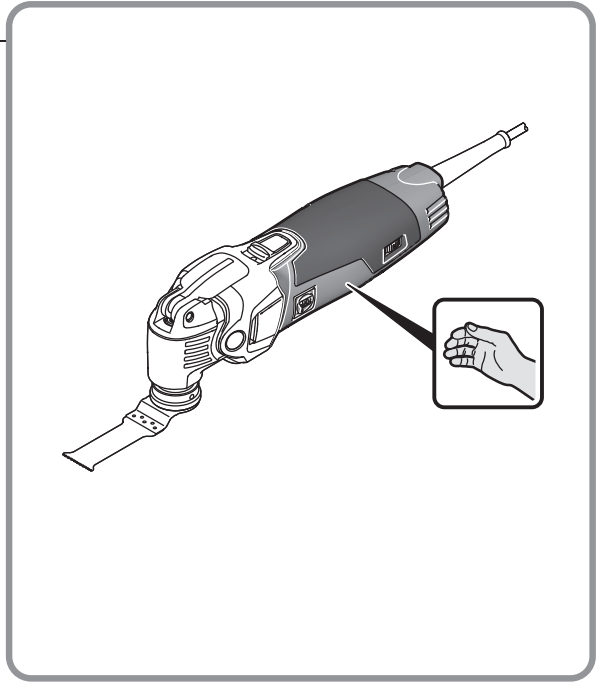
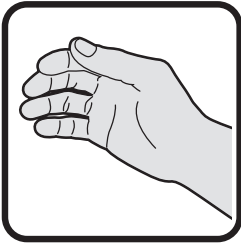

























Translation of the Original Instructions.

Symbols, abbreviations and terms used.

Symbol, character	Explanation
	Make sure to read the enclosed documents such as the Instruction Manual and the General Safety Instructions.
	Do not touch the saw blade. Danger of sharp application tools moving back and forth.
	Warning against sharp edges of application tools, such as the cutting edges of the cutter blades.
	Observe the instructions in the text or graphic opposite!
	General prohibition sign. This action is prohibited.
	Before commencing this work step, pull the mains plug out of the socket. Otherwise there will be danger of injury if the power tool should start unintentionally.
	Use eye protection during operation.
	Use ear protection during operation.
	Use a dust mask during operation.
	Use protective gloves during operation.
	Gripping surface
	Observe the information in the adjacent text!
	Switching on
	Switching off
	Confirms the conformity of the power tool with the directives of the European Community.
	Confirms the conformity of the power tool with the directives of Great Britain (England, Wales, Scotland).
	This sign indicates a possible dangerous situation that could cause severe or fatal injury.
	Worn out power tools and other electrotechnical and electrical products should be sorted separately for environmental-friendly recycling.
	Product with double or reinforced insulation
	Low oscillation rate
	High oscillation rate
(**)	may contain numbers and letters
(Ax - Zx)	Marking for internal purposes

Character	Unit of measurement, international	Unit of measurement, national	Explanation
P_1	W	W	Power input
P_2	W	W	Output
U	V	V	Rated voltage
f	Hz	Hz	Frequency
n_s	/min, min^{-1} , rpm, r/min	/min	Rated oscillation rate
	°	°	Oscillation angle
	kg	kg	Weight according to EPTA-Procedure 01
L_{pA}	dB	dB	Sound pressure level
L_{wA}	dB	dB	Sound power level
L_{pCpeak}	dB	dB	Peak sound pressure level
$K_{...}$			Uncertainty
a	m/s^2	m/s^2	Vibrational emission value according to EN 62841 (vector sum of three directions)
	m, s, kg, A, mm, V, W, Hz, N, °C, dB, min , m/s^2	m, s, kg, A, mm, V, W, Hz, N, °C, dB, min , m/s^2	Basic and derived units of measurement from the international system of units SI .

For your safety.

WARNING Read all safety warnings and all instructions. Failure to follow the warnings and instructions may result in electric shock, fire and/or serious injury.

Save all warnings and instructions for future reference.



Do not use this power tool before you have thoroughly read and completely understood this Instruction Manual and the enclosed "General Safety Instructions" (document number 3 41 30 465 06 0). The documents mentioned should be kept for later use and enclosed with the power tool, should it be passed on or sold.

Please also observe the relevant national industrial safety regulations.

Intended use of the power tool:

Hand-guided oscillator for sanding small surfaces, corners and edges, for sawing thin parts of steel sheet, wood and plastic, for scraping, polishing, rasping, cutting and separating without water in weather-protected environments, using the application tools and accessories recommended by FEIN.

This power tool is also suitable for use with AC generators with sufficient power output that correspond to the Standard ISO 8528, design type G2. This Standard is particularly not complied with when the so-called distortion factor exceeds 10 %. When in doubt, please refer to the generator instruction/specification guide.

Special safety instructions.

Hold power tool by the insulated gripping surfaces, when performing an operation where the cutting accessory may contact hidden wiring or its own cord. Cutting accessory contacting a "live" wire may make exposed metal parts of the power tool "live" and could give the operator an electric shock.

Use clamps or another practical way to secure and support the workpiece to a stable platform. Holding the work by hand or against your body leaves it unstable and may lead to loss of control.

Do not use accessories which are not specifically designed and recommended by the power tool manufacturer. Safe operation is not ensured merely because an accessory fits your power tool.

Grasp the power tool in such a safe manner that your body never comes into contact with the application tool, especially while working with application tools such as saw blades or other blades pointed toward the grasping range. Touching sharp tips or cutting edges can lead to injuries.

Wear personal protective equipment. Depending on application, use face shield, safety goggles or safety glasses. Where appropriate, wear dust mask, hearing protectors, gloves and workshop apron capable of stopping small abrasive or workpiece fragments. The eye protection must be capable of stopping flying debris generated by various operations. The dust mask or respirator must be capable of filtering particles generated by your operation. Prolonged exposure to high intensity noise may cause hearing loss.

Do not direct the power tool against yourself, other persons or animals. Danger of injury from sharp or hot application tools.

Do not rivet or screw any name-plates or signs onto the power tool. If the insulation is damaged, protection against an electric shock will be ineffective. Adhesive labels are recommended.

Clean the ventilation openings on the power tool at regular intervals using non-metal tools. The blower of the motor draws dust into the housing. An excessive accumulation of metallic dust can cause an electrical hazard.

Before putting into operation, check the mains connection and the mains plug for damage.

Recommendation: The tool should always be supplied with power via a residual current device (RCD) with a rated current of 30 mA or less.

After working gypsum-containing materials: Blow out the ventilation openings of the power tool and the switch element with dry and oil-free compressed air. Otherwise, gypsum-containing dust can settle in the power tool housing and switch element, which can harden in connection with humidity. This can impair the switching mechanism.

Handling hazardous dusts

For work procedures with this power tool where material is removed, dusts develop that can be hazardous to one's health.

Contact with or inhaling some dust types, e. g. asbestos and asbestos-containing materials, lead-containing coatings, metal, some wood types, minerals, silicate particles from materials containing stone, paint solvents, wood preservatives, antifouling paints for vessels, can trigger allergic reactions to the operator or bystanders and/or lead to respiratory infections, cancer, birth defects or other reproductive harm. The risk from inhaling dusts depends on the exposition. Use dust extraction matched appropriately for the developing dust, as well as personal protective equipment and provide for good ventilation of the workplace. Leave the processing of asbestos-containing materials to specialists.

Wood and light-metal dust, hot mixtures of grinding dust and chemical materials can self-ignite under unfavourable conditions or cause an explosion. Avoid sparking in the direction of the dust collector as well as overheating of the power tool and the materials being sanded, empty the dust collector/container in time, observe the material manufacturer's working instructions, as well as the relevant regulations in your country for the materials being worked.

Hand/arm vibrations

The vibration emission level given in this information sheet has been measured in accordance with a standardised test given in EN 62841 and may be used to compare one tool with another. It may be used for a preliminary assessment of exposure.

The declared vibration emission level represents the main applications of the tool. However, if the tool is used for different applications, with different accessories or poorly maintained, the vibration emission may differ. This may significantly increase the exposure level over the total working period.

An estimation of the level of exposure to vibration should also take into account the times when the tool is switched off or when it is running but not actually doing the job. This may significantly reduce the exposure level over the total working period.

Identify additional safety measures to protect the operator from the effects of vibration such as: maintain the tool and the accessories, keep the hands warm, organisation of work patterns.

Emission values for vibration

Vibration	a
Classification of FEIN application tools according to vibration class	Weighted acceleration*
VC0	$< 2,5 \text{ m/s}^2$
VC1	$< 5 \text{ m/s}^2$
VC2	$< 7 \text{ m/s}^2$
VC3	$< 10 \text{ m/s}^2$
VC4	$< 15 \text{ m/s}^2$
VC5	$< 30 \text{ m/s}^2$
K_a	$1,5 \text{ m/s}^2$

* These values are based on a work cycle consisting of no-load and full-load operation of the same duration.

For information on the vibration class assigned to the application tool, please see the enclosed data sheet 3 41 30 513 06 0.

Operating Instructions.

Do not use accessories not specifically intended and recommended for this power tool by FEIN. The use of non-original FEIN accessories can lead to overheating of the power tool and destroy it.

Changing the tool (see pages 5/6).

 **Do not switch the power tool on while the clamping lever is open.** Otherwise there is danger of crushes or contusions to the hand and fingers.

 **Do not reach into the area of the clamping jaws.** Otherwise there is danger of crushes or contusions to the fingers.

Additional operating instructions.

 **Do not actuate the clamping lever while the power tool is running.** Otherwise there is danger of injury.

 **Do not operate the power tool with open clamping jaws and without an application tool!** This could damage the power tool.

 **When the clamping jaws are open before the application tool is inserted, pivot the clamping lever toward the front and then back again.** The clamping jaws are closed now. The application tool can be inserted.

 **Do not overload the power tool.** Overloading increases the vibration on the power-tool housing and can cause the power tool to become very hot. Danger of injury.

 **Guide the power tool toward the work piece only when switched on.**

The application tool can be offset in 30° steps and fastened in the most favourable working position.

Notes on sanding.

Press the power tool with the sanding sheet briefly and firmly against a flat surface and briefly switch the power tool on. This provides for good adhesion and prevents premature wear.

When only one tip or corner of the sanding sheet is worn, it can be removed again and reattached turned by 120°.

Work with the entire surface of the sanding plate, not only with the tip.

When sanding with small triangle sanding plates, select a high oscillating frequency (electronics level 4 – 6); when sanding with the round sanding plate and the large triangle sanding plate, select a moderate oscillating frequency (max. electronics level 4).

Sand with continuous motion applying moderate pressure. Applying excessive pressure does not increase the rate of removal, it only wears off the sanding sheet faster.

Notes on profile sanding.

Select a medium oscillating frequency.

Notes on sawing.

Select a high oscillating frequency. Round saw blades can be released and clamped offset again, to allow for uniform wearing off.

Notes on scraping.

Select a moderate to high oscillating frequency.

Repair and customer service.



When working metal under extreme operating conditions, it is possible for conductive dust to settle in the interior of the power tool. The total insulation of the power tool can be impaired. Blow out the interior of the power tool via the ventilation slots frequently with dry and oil-free compressed air, and connect a residual current device (RCD) on the line side.

When working gypsum-containing materials, dust can settle within the power tool and switch element, which can harden in connection with humidity. This can impair the switching mechanism. Blow out the interior of the power tool via the ventilation slots and the switch element frequently with dry and oil-free compressed air.

Products that have come into contact with asbestos may not be sent in for repair. Dispose of products contaminated with asbestos according to the applicable country-specific regulations for such disposal.

When the machine's power supply cord is damaged, it must be replaced by the manufacturer or their representative.

The current spares parts list for this power tool can be found on our website at www.fein.com.

Use only original spare parts.

If required, you can change the following parts yourself:

Application tools

Warranty and liability.

The warranty for the product is valid in accordance with the legal regulations in the country where it is marketed. In addition, FEIN also provides a guarantee in accordance with the FEIN manufacturer's warranty declaration.

The delivery scope of your power tool may include only a part of the accessories described or shown in this Instruction Manual.

Declaration of conformity.

This **CE declaration** is only valid for European Union and EFTA (European Free Trade Association) countries and only for products intended for the EU- or EFTA market. After placing the product on the EU market the UKCA mark loses its mark validity.

The **UKCA declaration** is only valid for the Great Britain market (England, Wales and Scotland) and only for products intended for the Great Britain market.

After placing the product on the Great Britain market the CE mark loses its mark validity.

FEIN declares itself solely responsible for this product conforming with the relevant provisions given on the last page of this Instruction Manual.

Technical documents at: C. & E. Fein GmbH, D-73529 Schwäbisch Gmünd

Environmental protection, disposal.

Packaging, worn out power tools and accessories should be sorted for environmental-friendly recycling.