

| | | |
|----|---|----|
| de | Originalbetriebsanleitung - Absaugmobil | 8 |
| en | Original Instructions - Mobile dust extractors | 14 |
| fr | Notice d'utilisation d'origine - Aspirateurs mobile | 20 |
| es | Manual de instrucciones original - Sistemas móviles de aspiración | 26 |
| it | Istruzioni per l'uso originali - Unità mobili d'aspirazione | 32 |
| nl | Originele gebruiksaanwijzing - Mobiele afzuigapparaten | 38 |
| sv | Originalbruksanvisning - Dammsugare | 44 |
| fi | Alkuperäiset käyttöohjeet - Siirrettävät imurit | 49 |
| da | Original brugsanvisning - Støvsugere | 55 |
| nb | Originalbruksanvisning - Mobil støv-/våtsuger | 61 |
| pt | Manual de instruções original - Aspiradores móveis | 66 |
| cs | Originál návodu k obsluze - Mobilní vysavače | 72 |
| pl | Oryginalna instrukcja eksploatacji - Odkurzacze mobilne | 78 |

CT 15 E CT 25 E

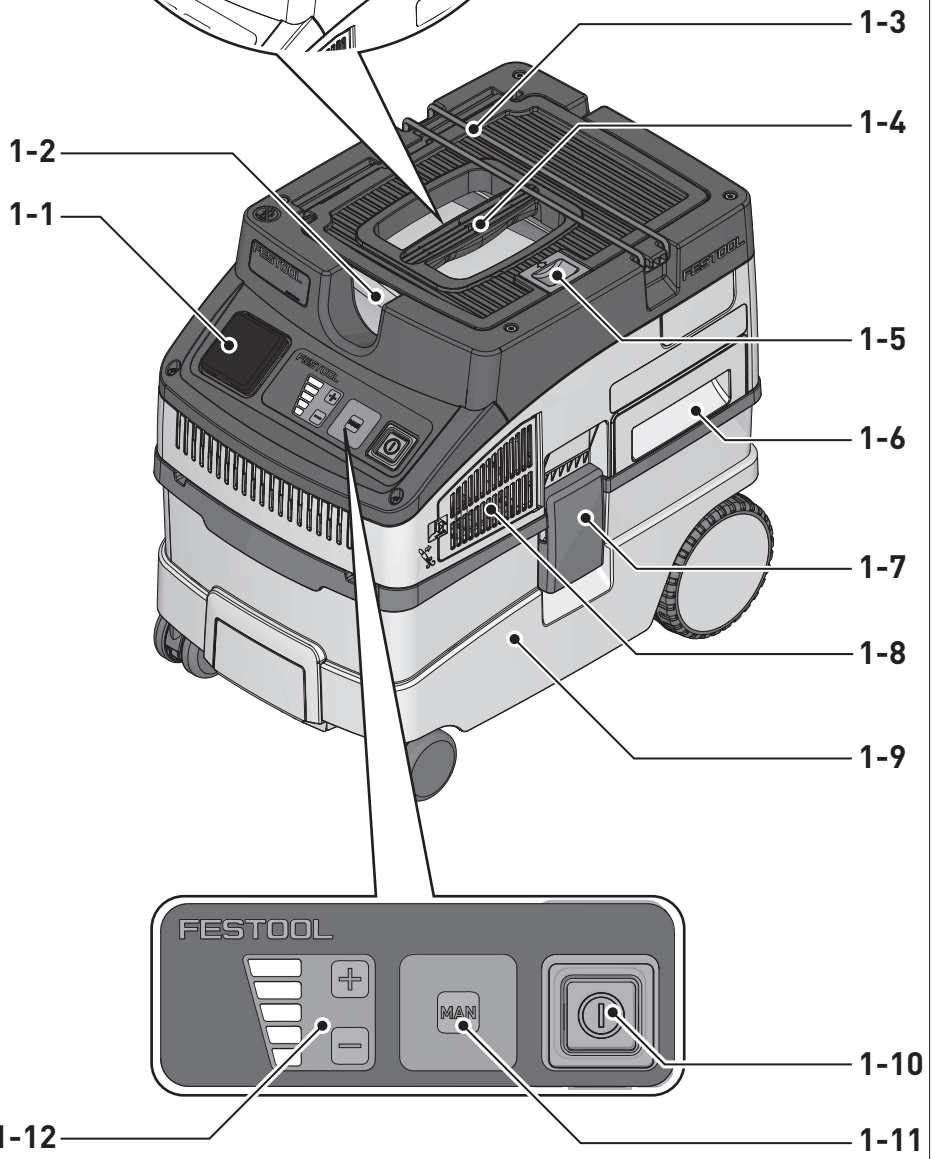

1

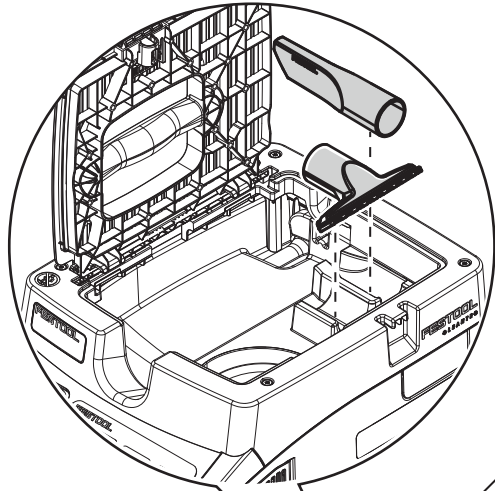

2

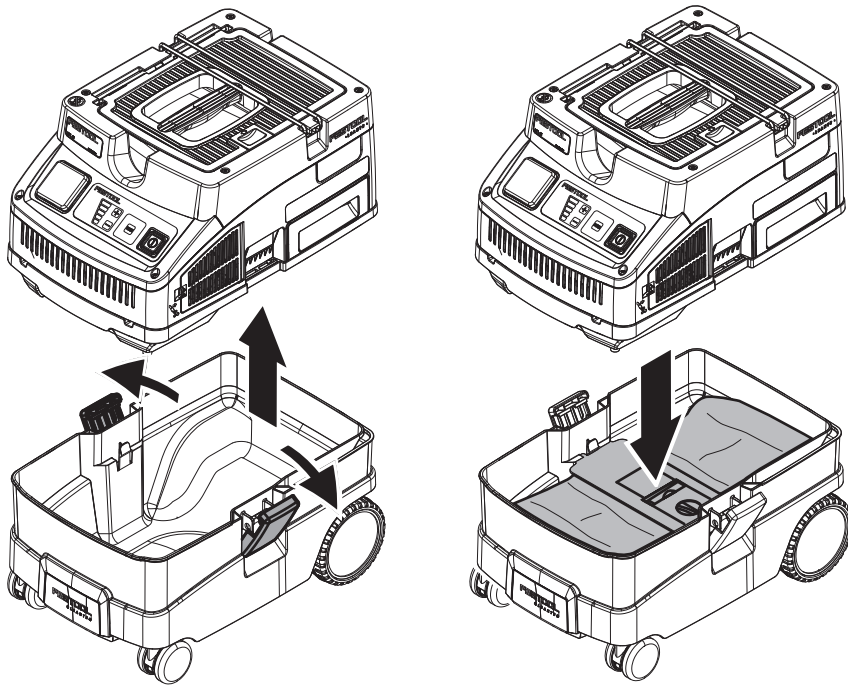

3

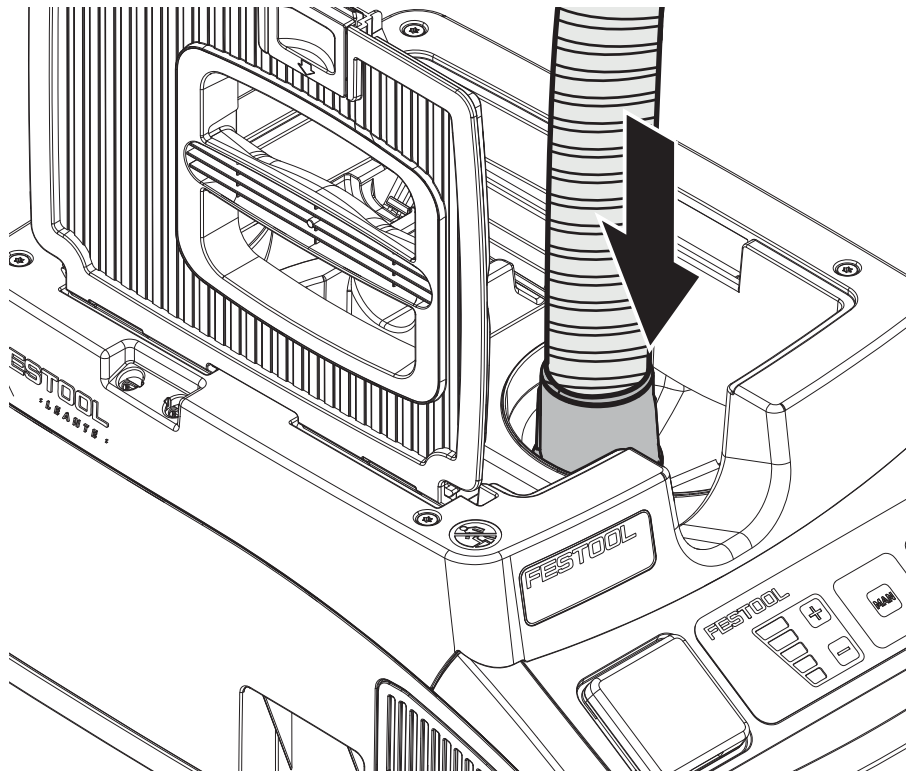

4

4-1

4-2

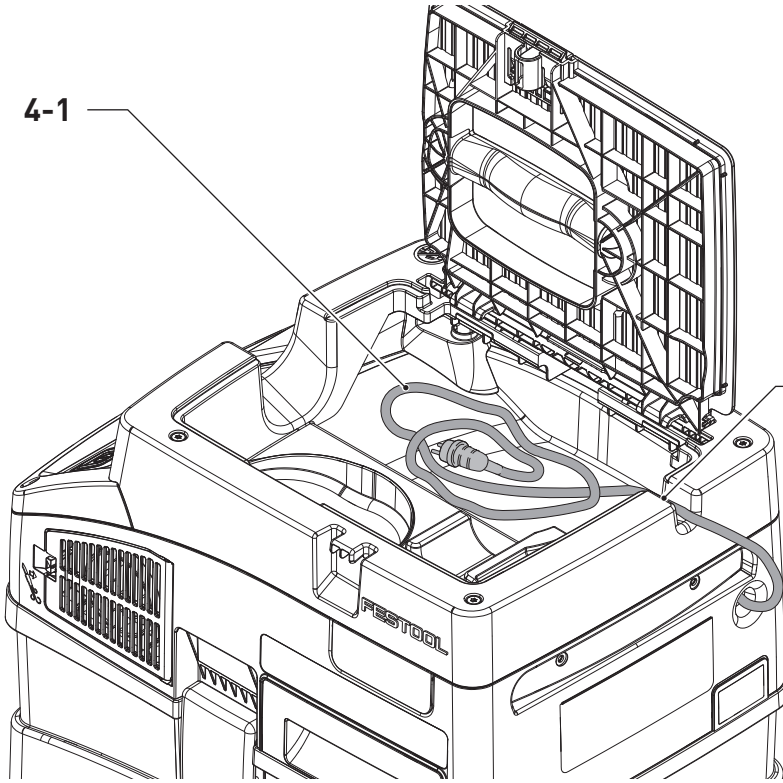

5

5-1

1-3

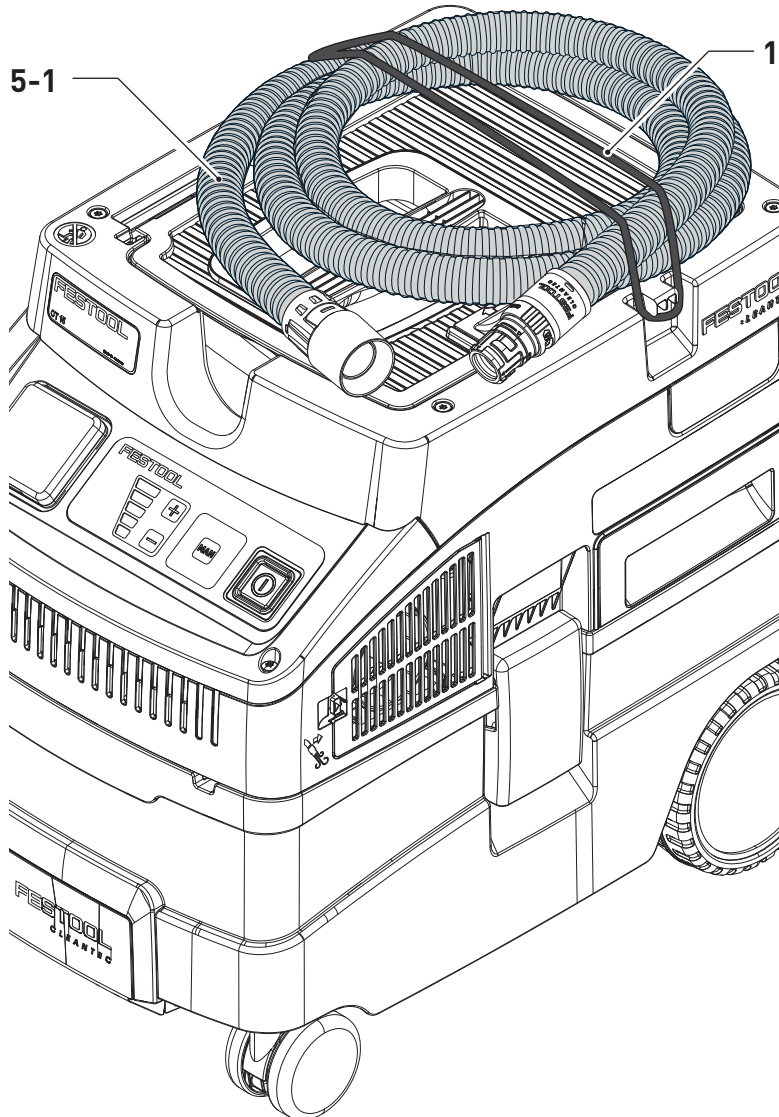

6

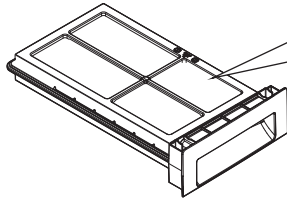
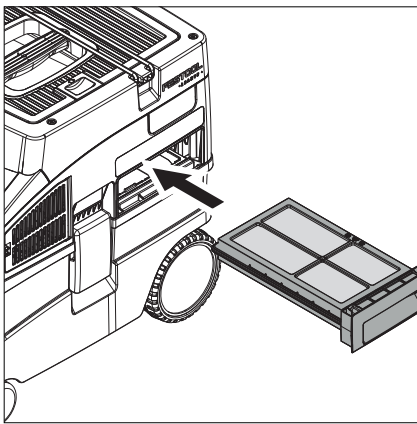
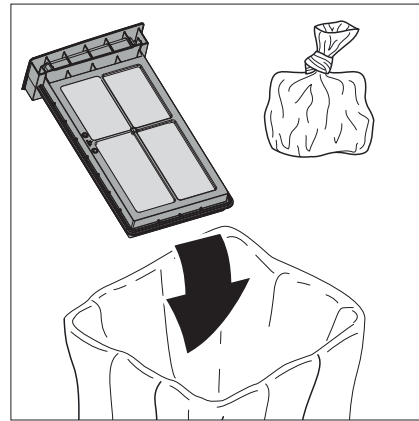
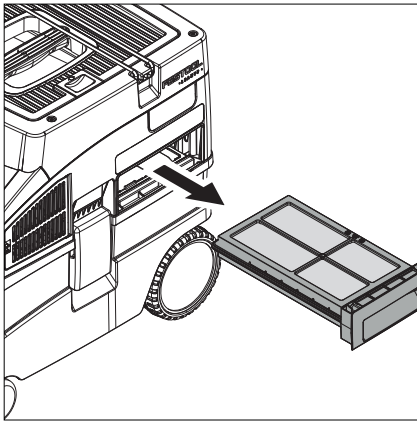

Festool-Katalog
Festool-catalogue



~~HF-CT COMP
204 200~~



NF-CT COMP
204 202

7

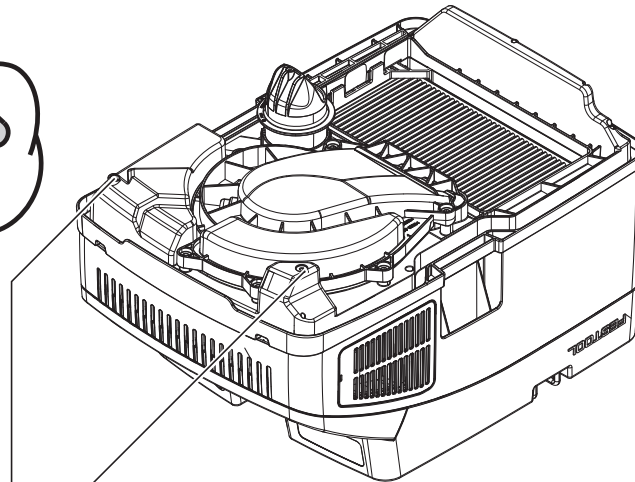
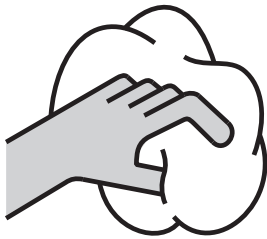

7-1

Mobile dust extractor**Serial number ¹⁾
(T-Nr.)**

CT 15 E

201944, 10766198

CT 25 E

10664965, 10792066

We as the manufacturer declare under our sole responsibility that the product(s) fulfill(s) all the relevant provisions of the following UK Regulations and are manufactured in accordance with the following designated standards:

S.I. 2008/1597 Supply of Machinery [Safety] Regulations 2008
S.I. 2016/1091 Electromagnetic Compatibility Regulations 2016
S.I. 2012/3032 Restriction of the Use of Certain Hazardous Substances in Electrical
and Electronic Equipment Regulations 2012

BS EN 60335-1:2012 + A2:2019
BS EN 60335-2-69:2012
BS EN 62233:2008
BS EN 55014-1:2017
BS EN 55014-2:2015
BS EN IEC 61000-3-2:2019
BS EN 61000-3-3:2013
BS EN IEC 63000:2018



Signed on behalf of and in name of
Festool GmbH
Wertstr. 20, 73240 Wendlingen, GERMANY

Place and date of declaration: Wendlingen, 2023-05-25

ppa. 

Markus Stark
Head of Research & Development Products

i.A. 

Tim Weber
Head of Product Compliance

| Absaugmobile Mobile dust extractors Aspirateurs | Seriennummer ¹⁾ Serial number ¹⁾ N° de série ¹⁾ (T-Nr.) |
|--|---|
| CT 15 E | 201941, 201944, 201943, 10682075, 10704052, 10766197, 10766198, 10766201 |
| CT 25 E | 10591846, 10664964, 10664965, 10664968, 10792064, 10792065, 10792066, 10792069 |

de EU-Konformitätserklärung. Wir erklären in alleiniger Verantwortung, dass dieses Produkt mit allen relevanten Anforderungen folgender EU-Richtlinien übereinstimmt, und folgende Normen oder normative Dokumente zugrunde gelegt wurden:

en EU Declaration of Conformity. We declare under sole responsibility that this product complies with all the relevant requirements in the following EU Directives, and following standards or normative documents were applied:

fr Déclaration de conformité de l'UE. Nous déclarons, sous notre seule responsabilité, que ce produit satisfait à toutes les exigences pertinentes des directives UE suivantes et repose sur les normes ou documents normatifs suivants :

es Declaración UE de conformidad. Declaramos bajo nuestra responsabilidad que este producto cumple todos los requisitos relevantes de las siguientes directivas de la UE y que se han tomado como base las siguientes normas o documentos normativos:

it Dichiarazione di conformità UE. Dichiariamo sotto nostra unica responsabilità che il presente prodotto sia conforme a tutti i requisiti di rilevanza definiti dalle seguenti Direttive UE e che siano stati applicati le seguenti norme o i seguenti documenti normativi:

nl EU-conformiteitsverklaring. Wij verklaren en stellen ons ervoor verantwoordelijk dat dit product volledig voldoet aan alle volgende EU-richtlijnen en volgende normen of normatieve documenten daaraan ten grondslag gelegd werden:

sv EU-försäkran om överensstämmelse. Vi förklarar på eget ansvar att denna produkt uppfyller alla relevanta krav enligt följande EU-direktiv och baseras på följande normer eller normgivande dokument:

fi EU-vaatimustenmukaisuusvakuutus. Vakuutamme yksinomaisella vastuulla, että tämä tuote täyttää seuraavien EU-direktiivien kaikki olennaiset vaatimukset ja se on seuraavien standardien tai standardiasiakirjojen mukainen:

da EU-overensstemmelseserklæring. Vi erklærer med eneansvar, at dette produkt er i overensstemmelse med alle relevante krav i følgende EU-direktiver, og at følgende standarder eller normative dokumenter danner grundlag for det:

nb EU-samsvarserklæring. Vi erklærer under eneansvar at dette produktet oppfyller alle relevante krav i

følgende EU-direktiver og at følgende standarder eller normative dokumenter er blitt lagt til grunn:

pt Declaração de conformidade UE. Sob nossa inteira responsabilidade, declaramos que este produto está de acordo com todas as exigências relevantes das seguintes diretivas UE, tendo sido tomadas por base as seguintes normas ou documentos normativos:

ru Декларация о соответствии ЕС. Мы со всей ответственностью заявляем, что данная продукция соответствует всем применимым требованиям следующих Директив ЕС, стандартов и нормативных документов:

cs Prohlášení o shodě EU. Prohlašujeme s veškerou odpovědností, že tento výrobek splňuje všechny příslušné požadavky následujících směrnic EU a že byly použity následující normy nebo normativní dokumenty:

pl Deklaracja zgodności UE. Niniejszym oświadczamy na własną odpowiedzialność, że produkt ten spełnia wszystkie obowiązujące wymagania następujących dyrektyw UE, norm lub dokumentów normatywnych.

2006/42/EC, 2014/30/EU²⁾, 2014/53/EU³⁾,
2011/65/EU

EN 60335-1:2012 + A11:2014 + A13:2017,
EN 60335-2-69:2012, EN 62233:2008,
EN 55014-1:2017 + A11:2020 ²⁾, EN 55014-2:2015 ²⁾,
EN 61000-3-2:2014 ^{2) 3)}, EN 61000-3-3:2013 ^{2) 3)},
EN 300 328 V2.2.2 ³⁾, EN 301 489-1 V2.1.1 ³⁾,
EN 300 330 V2.1.1 ³⁾, EN IEC 62311:2020 ³⁾,
EN IEC 63000:2018



Unterzeichnet für und im Namen von/
Signed on behalf of and in name of/
Signé pour et au nom de

Festool GmbH

Wertstr. 20, 73240 Wendlingen, GERMANY
Wendlingen, 2023-05-25

Markus Stark
Head of Research & Development Products

Tim Weber
Head of Product Compliance

¹⁾ im definierten Seriennummer-Bereich (S-Nr.) von 40000000 - 49999999/
in the specified serial number range (S-Nr.) from 40000000 - 49999999/
dans la plage de numéro de série (S-Nr.) de 40000000 - 49999999

²⁾ gilt für Geräte ohne Bluetooth®/ valid for machines without Bluetooth®/ s'applique aux dispositifs sans Bluetooth®

³⁾ gilt für Geräte mit Bluetooth®/ valid for machines with Bluetooth®/ s'applique aux dispositifs avec Bluetooth®

| | |
|--------------------------------|----|
| Contents | |
| 1 Safety warnings..... | 14 |
| 2 Symbols..... | 15 |
| 3 Parts of the machine..... | 15 |
| 4 Technical data..... | 16 |
| 5 Intended use..... | 16 |
| 6 Commissioning..... | 16 |
| 7 Settings..... | 17 |
| 8 Working..... | 17 |
| 9 Service and maintenance..... | 18 |
| 10 Environment..... | 19 |
| 11 General information..... | 19 |

1 Safety warnings



WARNING! Read all safety warnings and instructions. Failure to follow the safety warnings and instructions may result in electric shock, fire and/or serious injury.

Save all safety warnings and instructions for future reference.

- This machine is not intended for use by persons (including children) with reduced physical, sensory or mental capabilities, or lack of experience and knowledge. **Children** should be supervised to ensure that they do not play with the appliance.
- If the **supply cord** is damaged, it must be replaced by an authorised service workshop in order to avoid a hazard.
- Always operate with the filter system installed!
- **WARNING** Operators shall be adequately instructed on the use of these machines.
- The mains plug must always be disconnected from the socket before performing cleaning or maintenance tasks, when replacing consumables or when converting the machine.
- **WARNING** Only use the socket outlet on the machine for purposes specified in the instructions.
- **WARNING** If foam or liquid escapes from the machine, switch off immediately.
- **CAUTION** Clean the water level limiting device regularly and examine it for signs of damage.
- Not suitable for extracting fluids that foam excessively.
- **WARNING** This machine is not suitable for picking up hazardous dust.
- **CAUTION** This machine is for indoor use only.
- **CAUTION** This machine shall be stored indoors only.
- **Risk of explosion and fire! Do not extract:**
 - Sparks, glowing particles or hot dust;
 - combustible or explosive materials (e.g. magnesium, aluminium, petrol, diluting agents);
 - aggressive materials (e.g. acid, alkaline solutions, solvents);
 - chemically reactive materials which lead to the generation of heat, acids/bases, gases, etc. (e.g. reactive two-component materials, aluminium and water).



- Observe all national safety regulations as well as the material manufacturer's specifications!
- Always use suitable protective equipment!
- If intact following a visual inspection, work in a dry environment according to instructions!
- Check the plug, the electrical outlet module, the cable and the filter regularly in order to prevent a hazard. Damaged electrical components must be replaced by an authorised service workshop only.
- Only carry the machine using the handle provided.
- Do not lift or transport using a crane hook or lifting gear.
- The mobile dust extractor must not be carried by the suction hose mount **[1-3]**.
- Only place the tool on level ground and secure it against rolling away.
- This machine must not be used by people who might have a particularly adverse reaction to an electric shock (e.g. **people with cardiac pacemakers**), because the possibility of the machine building up a static charge cannot be excluded.
- Use only the original Festool suction hose.
- **Pay attention to the work environment and watch out for your own safety and the safety of others when transporting or working with the machine.**





In this way, you can for example prevent tripping hazards caused by the suction hose or mains cable.

- **Keep packaging film away from children.**

There is a risk of suffocation.

2 Symbols

-  Warning of general danger
-  Warning of electric shock
-  Read the operating manual and safety warnings.
-  Read the operating manual and safety warnings.
-  Do not dispose of it with domestic waste.
-  Pull out the mains plug
-  Wear a dust mask.

-  Do not climb on the unit
-  CE conformity marking
-  UKCA marking: Confirms the conformity of the product with UK regulations.
-  Tip or advice
-  Handling instruction

3 Parts of the machine

- [1-1]** Electrical outlet module
- [1-2]** Cable and accessory holder
- [1-3]** Suction hose mount
- [1-4]** Handle
- [1-5]** Lock
- [1-6]** Filter drawer

| | |
|---------------|-----------------|
| [1-7] | Locking clip |
| [1-8] | Exhaust opening |
| [1-9] | Dirt trap |
| [1-10] | On/off switch |

| | |
|---------------|--------------------------|
| [1-11] | MAN button |
| [1-12] | Suction power adjustment |

The specified illustrations appear at the beginning of the Operating Instructions.

4 Technical data

| Mobile dust extractors | | |
|--|---------|---|
| Power consumption | | 350 - 1200 W |
| Max. electrical outlet module connected load | EU | 2200 W |
| | CH, DK | 1150 W |
| | GB | 1610 W |
| Max. suction capacity (air), extractor/turbine | | 130 m ³ /h / 222 m ³ /h |
| Max. vacuum, turbine | | 24,000 Pa |
| Filter surface area | | 3508 cm ² |
| Suction hose | | D 27/32 mm x 3,5 m-RAS/CT |
| Mains power cable length | | 5.5 m |
| Sound pressure level as per EN 60335-2-69/ uncertainty K | | 70 dB(A)/ 3 dB |
| Hand-arm vibration value as per EN 60335-2-69/ uncertainty K | | <2.5 m/s ² / 1.5 m/s ² |
| Type of protection | | IP X4 |
| Container capacity | CT 15 E | 15 l |
| | CT 25 E | 25 l |
| Dimensions (LxWxH) | CT 15 E | 470x320x430 mm |
| | CT 25 E | 470x320x510 mm |
| Weight | CT 15 E | 11.2 kg |
| | CT 25 E | 12 kg |

5 Intended use

Mobile dust extractor suitable for

- Extracting non-hazardous dust, dirt, sand and chips,
- extracting water,
- for increased loads during commercial use, according to IEC/EN 60335-2-69.

The mobile dust extractor is only suitable for indoor use.



The user is liable for improper or non-intended use.

6 Commissioning



WARNING

Unauthorised voltage or frequency!

Risk of accidents

- Observe the specifications on the machine's name plate.
- Observe country-specific regulations.

6.1 Initial commissioning

- Insert the filter bag **[2]**.
- Connect the suction hose **[3]**.

6.2 Connecting the mobile dust extractor



WARNING

Risk of injury from uncontrolled tool start-up

- ▶ Before switching on ensure that the connected tool is switched off.



WARNING

Risk of injury from electric current

- ▶ Insert the mains plug into an earthed socket.
- ▶ Do not reach into the electrical outlet module on the mobile dust extractor.

- ⓘ While the mobile dust extractor is connected to the mains socket, an electric current is running through electrical outlet module on the mobile dust extractor at all times.

Connecting the mobile dust extractor to a mains socket

The mobile dust extractor is switched off.

- ▶ Connect the power cable to a mains socket. The electrical outlet module **[1-1]** is live.

Switching the mobile dust extractor to standby mode

- ▶ Press the on/off switch **[1-10]**. The electrical outlet module **[1-1]** is live.

- ⓘ The green LED **[1-12]** indicates standby mode.

Starting the mobile dust extractor automatically

The mobile dust extractor is in standby mode.

- ▶ To start the mobile dust extractor automatically: Switch on the connected tool.

Starting the mobile dust extractor manually

The mobile dust extractor is in standby mode.

- ▶ Press the MAN button **[1-11]**.



Pull the mains plug from the socket when you are not using the mobile dust extractor and before performing any cleaning and maintenance work.

6.3 Connecting power tools



WARNING

Risk of injury

- ▶ Observe the maximum electrical outlet module connected load (see section "Technical data").
- ▶ Switch off the power tool.

Connecting a mains-powered power tool to the mobile dust extractor

- ▶ Connect the power tool to the electrical outlet module **[1-1]**.

The power tool is connected to the mobile dust extractor via the power cable.

7 Settings

7.1 Adjusting the suction power

- ▶ Press the plus or minus button **[1-12]** while extracting.

7.2 Connecting sleeve

The bypass function of the connecting sleeve prevents strong suction from sanding machines and floor nozzles on smooth surfaces.

Open

- ▶ Turn the adjusting ring to the "OPEN" position.

Close

- ▶ Turn the adjusting ring to the "CLOSE" position.

7.3 Temperature cut-out

A temperature cut-out switches the mobile dust extractor off when it reaches a critical temperature to prevent overheating. The bottom LED **[1-12]** indicates a fault.

LED lights up red Excessive temperature

- ▶ Switch off the mobile dust extractor, let it cool down.
- ▶ Switch on the mobile dust extractor again after approx. five minutes.

8 Working

8.1 Dust extraction



Extracting dry materials

Always use a filter bag.

8.2 Extracting wet materials/liquids



Remove the filter bag!
Use a special wet filter.

The dust extraction stops automatically when the maximum fill level is reached.

The bottom LED [1-12] lights up red.

- ▶ Switch off the mobile dust extractor [1-10].
- ▶ Open the locking clips [1-7] and remove the top section of the machine.
- ▶ Empty the dirt trap [1-9].

After wet extraction, allow the wet filter to dry!
Dry the mobile dust extractor and dirt trap before extracting dry dust and before storing them.



CAUTION

Hazardous dust

Damage to the respiratory passage

- ▶ After extracting wet materials, remove the wet filter and replace it with the main filter for dry materials.



CAUTION

Escaping foam and liquids

- ▶ Switch off and empty the machine immediately.

8.3 Exhaust-air outlet



CAUTION

Hazardous dust

Damage to the respiratory passage

- ▶ Do not blow off any dust!

The exhaust-air outlet offers the option of diverting the exhaust air outside a building using the suction hose.

- ▶ Open the grille in front of the exhaust opening [1-8].
- ▶ Insert the suction hose in the exhaust opening [1-8].

8.4 Changing the filter bag with minimal dust

- ▶ Open the locking clips and remove the top section of the machine [2].
- ▶ Pull the tab on the filter bag until the filter bag opening is fully closed.

The filter bag is now securely closed and can be removed.

- ▶ Fit the top section of the machine and close the locking clips.

8.5 Changing the filter element [6]

- ▶ Pull out the used filter drawer [1-6].
- ▶ Dispose of the used filter drawer in accordance with statutory regulations.
- ▶ Insert the new filter drawer [1-6].

ⓘ Order numbers for accessories, filters and consumables in the Festool catalogue or online at "www.festool.com".

- **Only use original Festool accessories and consumables.** Only accessories tested and approved by Festool are safe and perfectly adapted to the machine and application.

NOTICE

Damage to the motor

- ▶ Never extract material without a main filter or with a damaged main filter, as this can damage the motor.

8.6 After finishing work

- ▶ Switch off the mobile dust extractor and pull out the mains plug.
- ▶ Empty the dirt trap.
- ▶ Vacuum and wipe the inside and outside of the mobile dust extractor to clean it.
- ▶ Wind up the mains power cable.
- ▶ Place the mains power cable [4-1] in the sealable holder. To do so, lay the power cable through the recess [4-2].
- ▶ Disconnect the suction hose [5-1] and secure it to the mobile dust extractor with the suction hose mount [1-3].
- ▶ Clean the fill level sensors [7-1] and inspect them for damage at regular intervals.
- ▶ Place the mobile dust extractor in a dry room inaccessible to unauthorised users.

ⓘ The lid of the holder also serves as a storage area for tools.

9 Service and maintenance



WARNING

Risk of injury, electric shock

- ▶ Always pull the mains plug from the socket before performing any servicing and maintenance work.
- ▶ All maintenance and repair work which requires the motor housing to be opened should always be carried out by an authorised service workshop.



Customer service and repairs must only be carried out by the manufacturer or service workshops. Find the nearest address at: www.festool.co.uk/service



Always use original Festool spare parts. Order no. at: www.festool.co.uk/service

10 Environment



Do not dispose of the device in the household waste! Recycle devices, accessories and packaging. Observe applicable national regulations.

In accordance with the European Directive on waste electrical and electronic equipment and implementation in national law, used power tools must be collected separately and handed in for environmentally friendly recycling.

Information on collection points for proper disposal can be found at www.festool.co.uk/recycling.

Information on REACH: www.festool.co.uk/reach

11 General information

Imported into the UK by

Festool UK Ltd
1 Anglo Saxon Way
Bury St Edmunds
IP30 9XH
Great Britain