

de	Originalbetriebsanleitung - Akku-Bohrschrauber	8
en	Original operating manual - Cordless drill	14
fr	Notice d'utilisation d'origine - Perceuses-visseuses sans fil	19
es	Manual de instrucciones original - Taladro atornillador de bateríaschrauber	25
it	Istruzioni per l'uso originali - Trapano avvitatore a batteria	31
nl	Originele gebruiksaanwijzing - Accuschroefboormachine	36
sv	Originalbruksanvisning - Batteri-borr/skruvdragare	42
fi	Alkuperäiset käyttöohjeet - Akkukäyttöinen porakone/ruuvinväännin	47
da	Original brugsanvisning - Akku bore-skruemaskine	52
nb	Originalbruksanvisning - Batteridrevet bor-/skrumaskin	57
pt	Manual de instruções original - Aparafusadora de acumulador	62
ru	Оригинальное руководство по эксплуатации - Аккумуляторная дрель-шуруповёрт	68
cs	Originální návod k použití - Vrtací akušroubovák	74
pl	Oryginalna instrukcja eksploatacji - Akumulatorowa wiertarko-wkrętarka	79

CXS

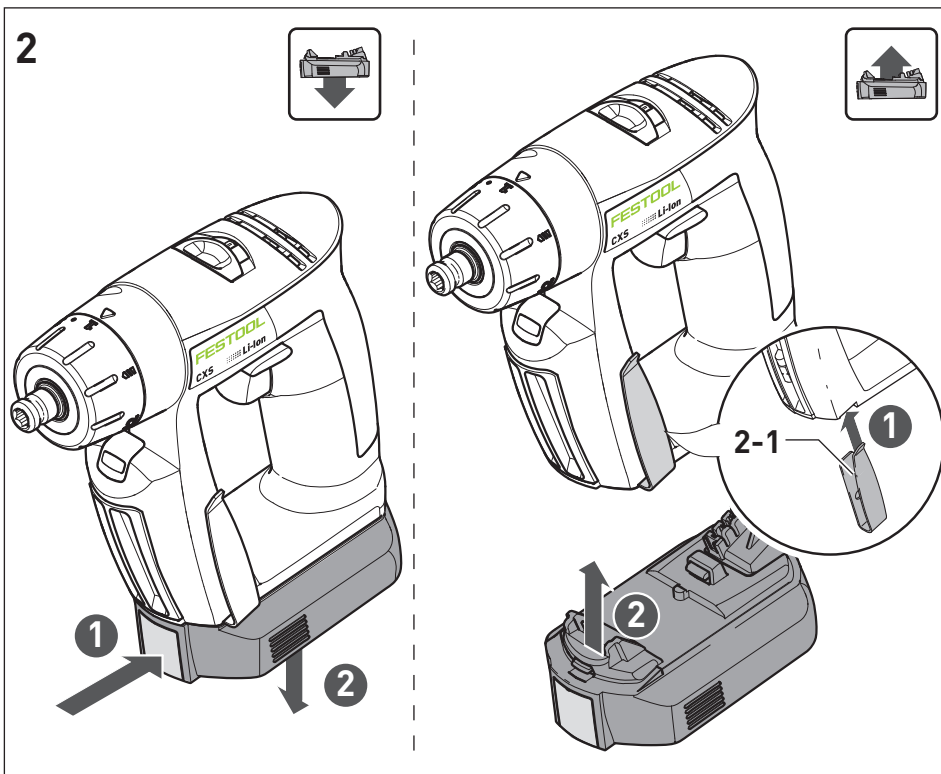

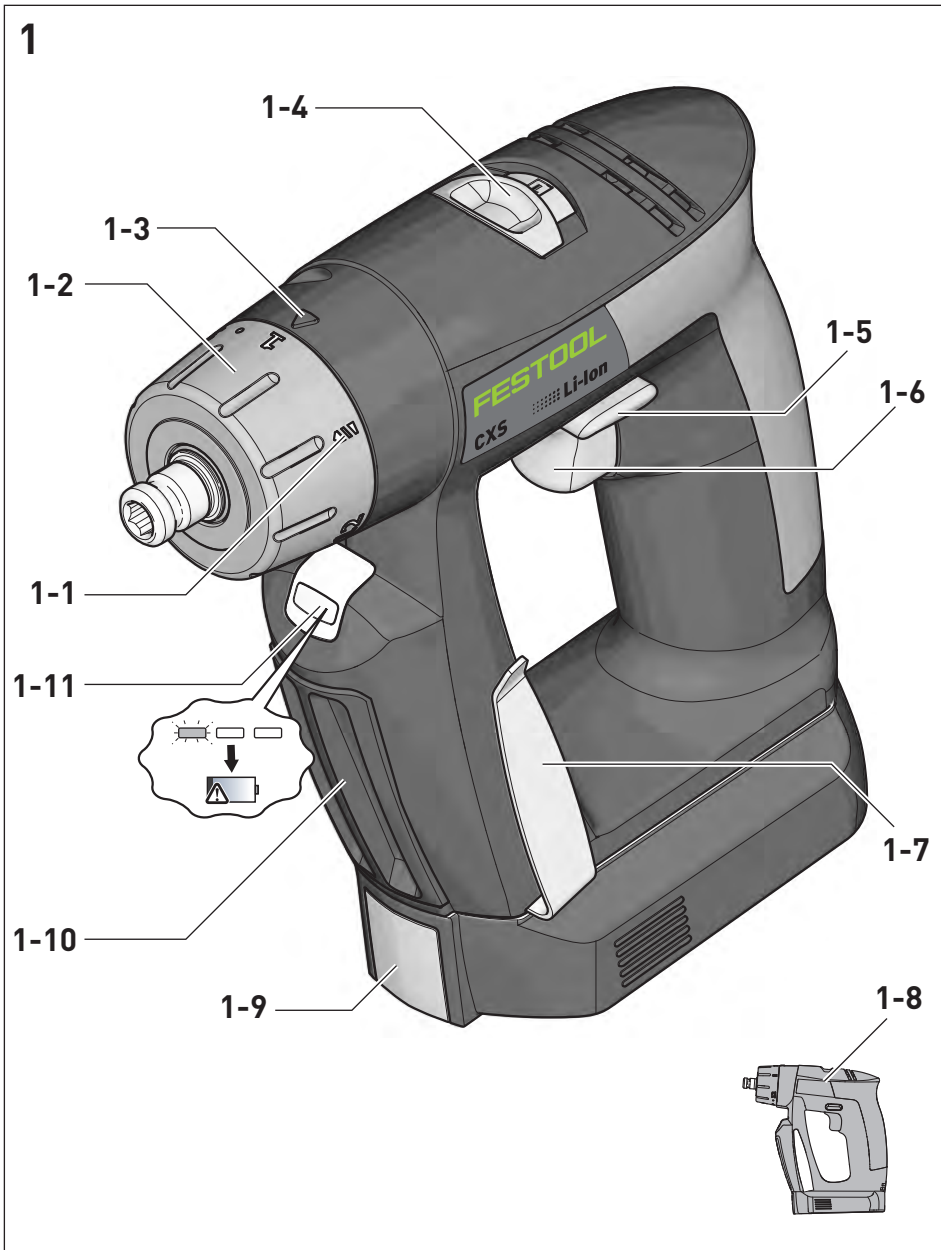

3

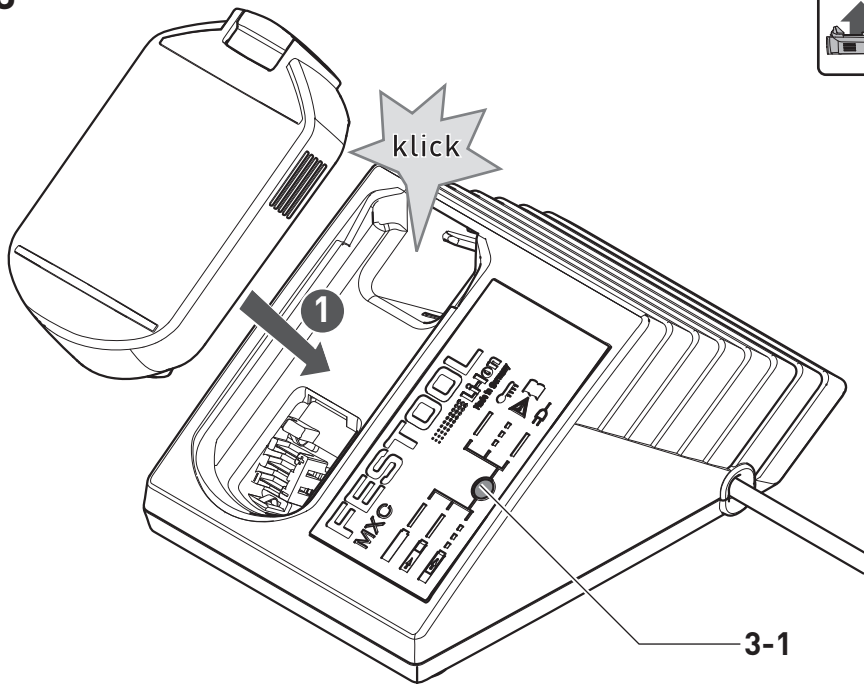

3

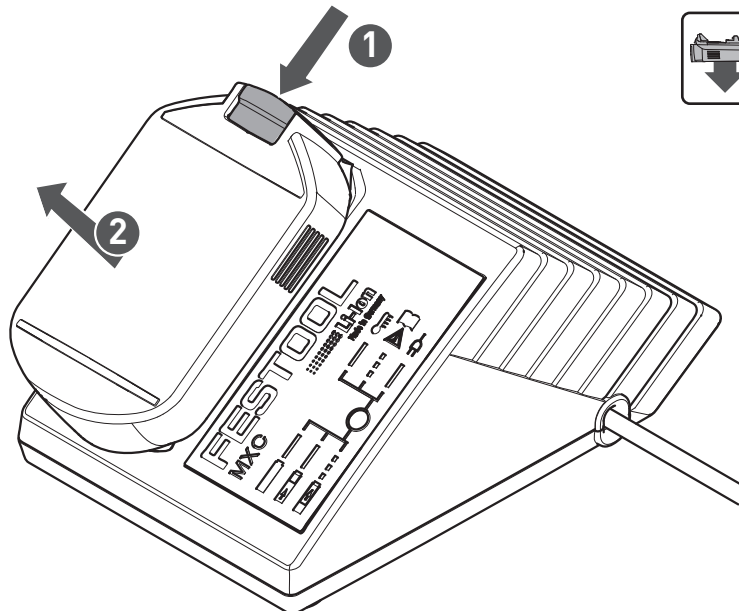

3A

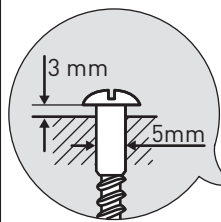

85 mm
[3 11/32"]

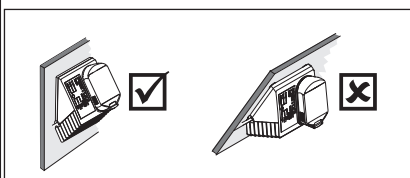
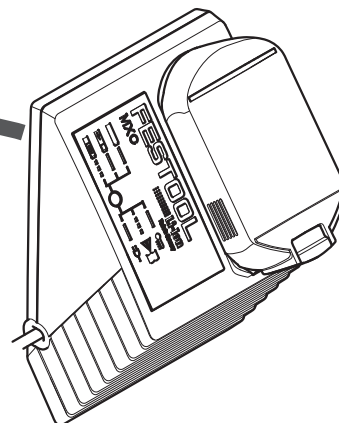

4

WH-CE
CENTROTEC®

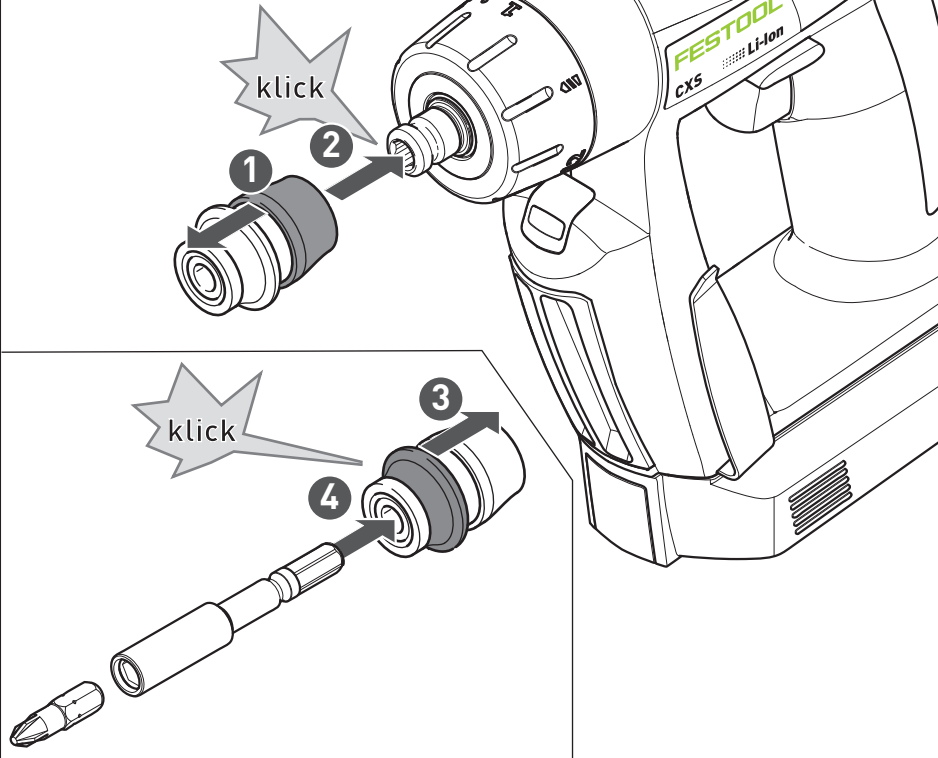

5

BF-FX 10

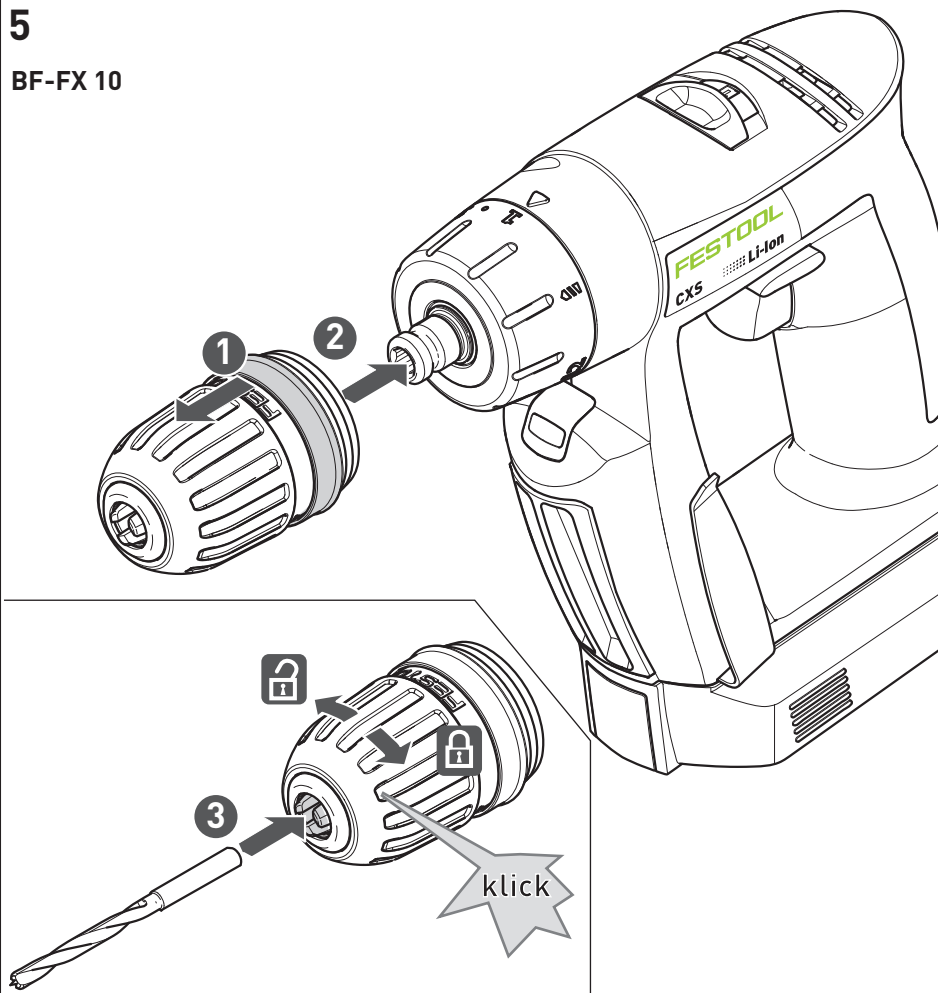

6

XS-AS

BF-FX 8

BF-FX 10

WH-CE

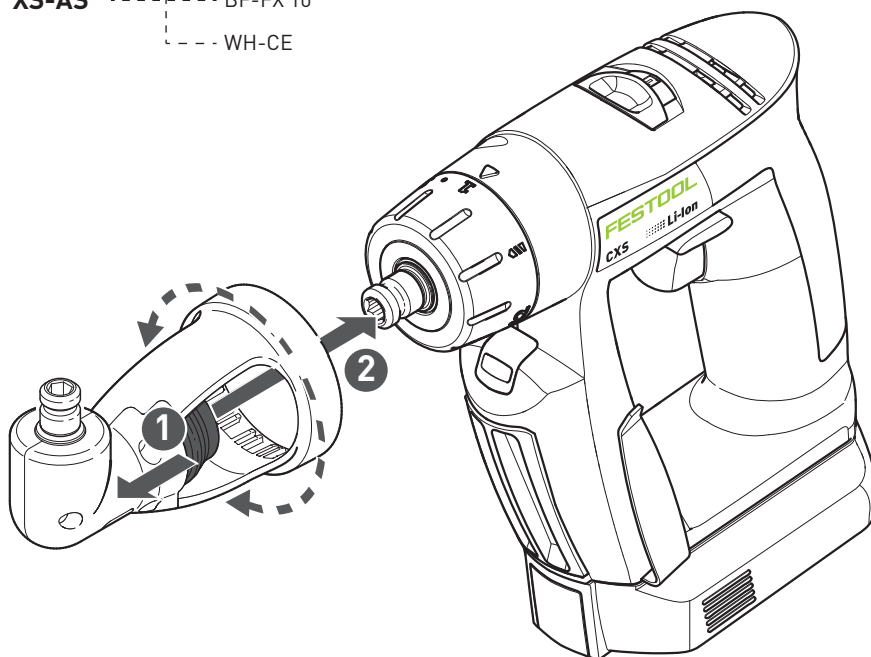

7

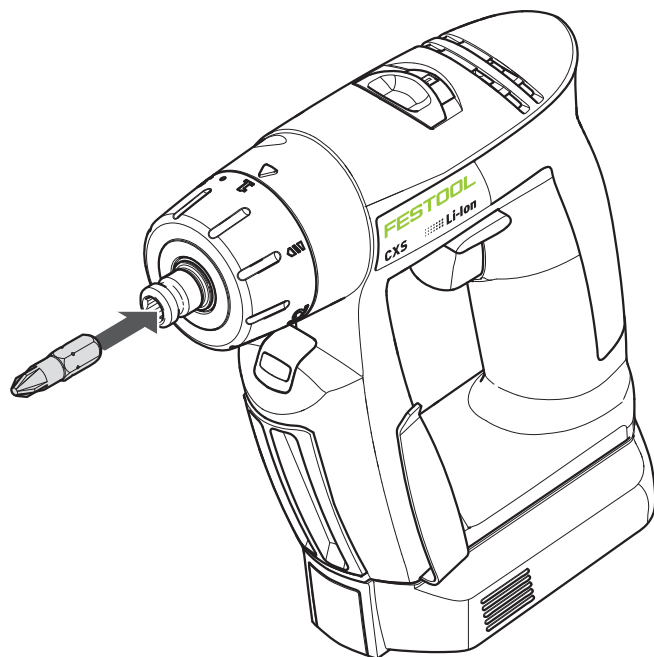

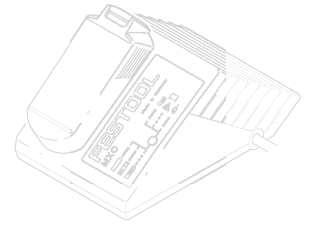

MXC		
	V~	220 - 240
	Hz	50/60
	V=	10,8
	A	2,6
	C	-10° - 40°
		II

Lilon 1,5 Ah	min.		~23
Lilon 2,6 Ah	min.		~45

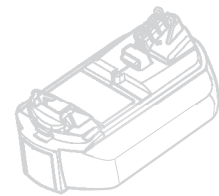

BP-XS		
		CXS, TXS
U	V=	10,8
	Ah	2,6
#		3
	C	0° - 55°
	kg	0,22

Akkuboehrschrauber	Seriennummer *
Cordless drill /	Serial number *
Screwdriver	
Perceuses-visseuses	N° de série *
sans fil	(T-Nr.)
CXS	10010708

2006/42/EG, 2014/30/EU, 2011/65/EU
 EN 62841-1: 2015 + AC:2015, EN 62841-2-1:2018,
 EN 62841-2-2:2014 + AC:2015, EN 55014-1: 2017,
 EN 55014-2: 2015, EN 50581: 2012

Ladegerät	Seriennummer *
Charger	Serial number *
Chargeur	N° de série *
	(T-Nr.)
MXC	204911

2014/35/EU, 2014/30/EU, 2011/65/EU
 EN 60335-1:2012 + A11:2014 + A13:2017, EN
 60335-2-29:2003 + A2, EN 62233:2008, EN 55014-
 1:2017, EN 55014-2:2015, EN 61000-3-2: 2014, EN
 61000-3-3: 2013 + A1:2017, EN 50581:2012

de EU-Konformitätserklärung. Wir erklären in alleiniger Verantwortung, dass dieses Produkt mit allen relevanten Anforderungen folgender EU-Richtlinien übereinstimmt, und folgende Normen oder normative Dokumente zugrunde gelegt wurden:

en EU Declaration of Conformity. We declare under sole responsibility that this product complies with all the relevant requirements in the following EU Directives, and following standards and normative documents were applied:

fr Déclaration de conformité de l'UE. Nous déclarons, sous notre seule responsabilité, que ce produit satisfait à toutes les exigences pertinentes des directives UE suivantes et repose sur les normes ou documents normatifs suivants :

es Declaración UE de conformidad. Declaramos bajo nuestra responsabilidad que este producto cumple todos los requisitos relevantes de las siguientes directivas de la UE y que se han tomado como base las siguientes normas o documentos normativos:

it Dichiarazione di conformità UE. Dichiariamo sotto nostra unica responsabilità che il presente prodotto sia conforme a tutti i requisiti di rilevanza definiti dalle seguenti Direttive UE e che siano stati applicati le seguenti norme o i seguenti documenti normativi:

nl EU-conformiteitsverklaring. Wij verklaren en stellen ons ervoor verantwoordelijk dat dit product volledig voldoet aan alle volgende EU-richtlijnen en volgende normen of normatieve documenten daaraan ten grondslag gelegd werden:

sv EU-försäkran om överensstämmelse. Vi förklarar på eget ansvar att denna produkt uppfyller alla relevanta krav enligt följande EU-direktiv och baseras

på följande normer eller normgivande dokument:

fi EU-vaatimustenmukaisuusvakuutus. Vakuutamme yksinomaisella vastuulla, että tämä tuote täyttää seuraavien EU-direktiivien kaikki olennaiset vaatimukset ja se on seuraavien standardien tai standardiasiakirjojen mukainen:

da EU-overensstemmelseserklæring. Vi erklærer med eneansvar, at dette produkt er i overensstemmelse med alle relevante krav i følgende EU-direktiver, og at følgende standarder eller normative dokumenter danner grundlag for det:

nb EU-samsvarserklæring. Vi erklærer under eneansvar at dette produktet oppfyller alle relevante krav i følgende EU-direktiver og at følgende standarder eller normative dokumenter er blitt lagt til grunn:

pt Declaração de conformidade UE. Sob nossa inteira responsabilidade, declaramos que este produto está de acordo com todas as exigências relevantes das seguintes diretivas UE, tendo sido tomadas por base as seguintes normas ou documentos normativos:

ru Декларация о соответствии ЕС. Мы со всей ответственностью заявляем, что данная продукция соответствует всем применимым требованиям следующих Директив ЕС, стандартов и нормативных документов:

cs Prohlášení o shodě EU. Prohlašujeme s veškerou odpovědností, že tento výrobek splňuje všechny příslušné požadavky následujících směrnic EU a že byly použity následující normy nebo normativní dokumenty:

pl Deklaracja zgodności UE. Niniejszym oświadczamy na własną odpowiedzialność, że produkt ten spełnia wszystkie obowiązujące wymagania następujących dyrektyw UE, norm lub dokumentów normatywnych.



Unterzeichnet für und im Namen von/
 Signed on behalf of and in name of/
 Signé pour et au nom de

Festool GmbH

Wertstr. 20, D-73240 Wendlingen
 GERMANY

Wendlingen, 2020-06-25

Markus Stark
 Head of Product Development

Ralf Brandt
 Head of Product Conformity

* im definierten Seriennummer-Bereich (S-Nr.) von 40000000 - 49999999

















in the specified serial number range (S-Nr.) from 40000000 - 49999999

dans la plage de numéro de série (S-Nr.) de 40000000 - 49999999

Contents

1	Symbols.....	14
2	Safety warnings.....	14
3	Intended use.....	15
4	Technical data.....	16
5	Machine features.....	16
6	Operation.....	16
7	Settings.....	16
8	Tool holder, attachments.....	17
9	Working with the machine.....	17
10	Service and maintenance.....	17
11	Environment.....	18
12	Transportation.....	18

1 Symbols

-  Warning of general danger
-  Warning of electric shock
-  Read the operating manual and safety instructions.
-  Wear ear protection.
-  Wear protective gloves.
-  Wear a dust mask.
-  Wear protective goggles.
-  Do not dispose of it with domestic waste.
-  Inserting the battery pack
-  Removing the battery pack
-  Tip or advice
-  Handling instruction
-  Permitted temperature range
-  Safety class II
-  Weight
-  Charging times
-  Mains voltage (input) and frequency

 Voltage (output)

 Rapid charging max.

 Capacity

 Number of cells

2 Safety warnings

2.1 General power tool safety warnings

 **WARNING! Read all safety warnings, instructions, illustrations and specifications provided with this power tool.** Failure to follow all instructions listed below may result in electric shock, fire and/or serious injury.

Save all warnings and instructions for future reference.

The term "power tool" used in the safety instructions refers to mains-powered power tools (with power cable) or battery-powered power tools (without power cable).

2.2 Machine-specific safety notices for cordless drills

- **Hold the power tool by insulated gripping surfaces, when performing an operation where the cutting accessory or fasteners may contact hidden wiring.** Cutting accessory contacting a "live" wire may make exposed metal parts of the power tool "live" and could give the operator an electric shock.
- **Use suitable detectors to determine if utility lines are hidden in the work area or call the local utility company for assistance.** A contact with electric lines can lead to fire and electric shock. Damaging a gas line can lead to explosion. Penetrating a water line causes property damage or may cause an electric shock.



- **Wear suitable personal protective equipment:** ear protection, safety goggles, a dust mask for work which generates dust, and protective gloves when working with raw materials and when changing tools.

 **CAUTION! Power tool can block and cause sudden kickback!** Switch off immediately!

- Do not lock the on/off switch permanently!

Safety instructions when using long drill bits

- **a) Never operate at higher speed than the maximum speed rating of the drill bit.** At higher speeds, the bit is likely to bend if allowed to rotate freely without contacting the workpiece, resulting in personal injury.
- **b) Always start drilling at low speed and with the bit tip in contact with the workpiece.** At higher speeds, the bit is likely to bend if allowed to rotate freely without contacting the workpiece, resulting in personal injury.
- **c) Apply pressure only in direct line with the bit and do not apply excessive pressure.** Bits can bend causing breakage or loss of control, resulting in personal injury.



2.3 Machine-specific safety instructions for battery pack and charger

- This charger can be operated by persons with reduced physical, sensory or mental capabilities or a lack of practical experience and knowledge, provided they are supervised or have been instructed to use the machine safely and understand the dangers of machine operation. **Children** are not allowed use or play with the machine.
- Do not open the battery pack or charger.
- Protect the charger from metal components (e.g. swarf) and liquids.
- **Do not use power adapters or battery packs from other manufacturers to operate the cordless power tool. Do not use any charger from other manufacturers for charging the battery pack.** The use of impermissible accessories may result in electric shock and / or serious accidents!
- Protect the battery pack from heat > 50 °C or constant heat sources such as sunlight or naked flames.
- Never use water to extinguish burning Li-ion battery packs; always use sand or a fire blanket.
- Check the plug and the cable regularly in order to prevent a hazard. In the event of damage, these must be replaced by an authorised service workshop only.
- Always pull the mains plug out of the socket when the charger is not in use.

2.4 Emission levels

The levels determined in accordance with 62841 are typically:

Sound pressure level	$L_{PA} = 64 \text{ dB(A)}$
Sound power level	$L_{WA} = 75 \text{ dB(A)}$
Uncertainty	$K = 3 \text{ dB}$

  **CAUTION**

Noise generated when working
Risk of damage to hearing
 ► Use ear protection.

Vibration emission level a_h (vector sum for three directions) and uncertainty K measured in accordance with 62841:

Fastening	$a_h = < 2.5 \text{ m/s}^2$ $K=1.5 \text{ m/s}^2$
Drilling in metal	$a_h = 3.0 \text{ m/s}^2$ $K=1.5 \text{ m/s}^2$

The specified emission levels (vibration, noise)

- are used to compare machines.
- They are also used for making preliminary estimates regarding vibration and noise load during operation.
- They represent the primary applications of the power tool.

 **CAUTION**

The emission values may deviate from the specified values. This is dependent on how the tool is used and the type of workpiece being machined.

- The actual load during the entire operating cycle must be evaluated.
- Depending on the actual load, suitable protective measures must be defined in order to protect the operator.

3 Intended use

Cordless drill suitable

- for screwing in and tightening screws,
- for drilling in metal, wood, plastics and similar materials.

Not intended for clamping tools other than drills and drill bits, e.g. compass saws, stirring rods, metal brushes.

Charger MXC suitable

- for charging the listed battery packs.
- only for indoor use.



The user is liable for improper or non-intended use; this also includes continuous industrial operation.

4 Technical data

Cordless drill	CXS
Motor voltage	10.8 V
No-load speed*	
1st gear	0–430 rpm
2nd gear	0–1300 rpm
Max. torque soft/hard screwdriving applica- tion	10/16 Nm
Adjustable torque	0.3–3.4 Nm
Chuck clamping range	1–10 mm
Max. drill diameter	
Wood/metal	12/8 mm
Tool holder in drill spindle	1/4"
Weight (incl. battery pack and chuck) as per EPTA procedure 01:2014	1.1 kg
Weight incl. battery pack and Centrotec	0.9 kg

* Speed values based on fully charged battery pack.



More technical data about the charger and the supplied battery pack can be found on page 6.

5 Machine features

- [1-1]** Drilling symbol
- [1-2]** Torque thumbwheel
- [1-3]** Torque/drilling position marking
- [1-4]** Gear switch
- [1-5]** Right/left switch
- [1-6]** On/Off switch
- [1-7]** Belt clip
- [1-8]** Insulated gripping surfaces (grey shaded area)
- [1-9]** Button for releasing the battery pack
- [1-10]** Bit store
- [1-11]** LED lamp with capacity indicator
- [3A]** Wall mount for charger

The specified illustrations appear at the beginning of the Operating Instructions.

The specified illustrations appear at the beginning of the Operating Instructions.

6 Operation

6.1 Changing the battery pack [2]



Battery pack is ready for use immediately upon delivery and can be charged at any time.



Side of the belt clip **[2-1]** can be replaced when battery pack is removed.

6.2 Charging the battery pack [3]

The LED **[3-1]** on the charger indicates the respective operating status of the charger.



LED yellow - continuous light

Charger is ready to use.



LED green - light flashes quickly

Battery pack is charged to maximum capacity.



LED green - light flashes slowly

Battery pack is charged to 80% and with reduced current.



LED green - continuous light

Battery pack is charged.



LED red - light flashes

General fault indicator, e.g. incomplete contact, short circuit, defective battery pack, etc.



LED red - continuous light

Battery temperature is outside permissible limit values (0 °C to 45 °C).

7 Settings



CAUTION

Risk of injury

- ▶ Only adjust the settings when the power tool is switched off.

7.1 Changing direction of rotation [1-5]

- Switch to the left = clockwise rotation
- Switch to the right = counterclockwise rotation

7.2 Changing gear [1-4]

 Only actuate the gear switch with the tool switched off. Otherwise there is a risk of damaging the gear unit.

- Gear switch forwards (digit 1 visible) = 1st gear
- Gear switch to rear (digit 2 visible) = 2nd gear

7.3 Adjust torque [1-2]

The marking [1-3] shows the selected position.

Drilling

Marking shows the drill symbol [1-1] = Maximum torque.

Fastening

Torque corresponding to setting:

Position 1 = low torque

Position 12 = high torque

8 Tool holder, attachments



WARNING

Risk of injury

- ▶ Remove the battery pack from the power tool before performing any work on the power tool.



CAUTION

Risk of injury from hot and sharp tool

- ▶ Do not use any blunt or faulty tools.
- ▶ Wear protective gloves.

The PO numbers of the accessories and tools can be found in the Festool catalogue or online at "www.festool.co.uk".

8.1 CENTROTEC tool chuck [4]

Quick change of tools with CENTROTEC shaft



Only clamp CENTROTEC tools in CENTROTEC tool chucks.

8.2 Chuck BF-FX10 [5]

For clamping drill bits and bits with max. shaft diameter of 10 mm.



Clamp tool centrally in the chuck.

8.3 Angle attachment XS-AS [6]

(accessories) Drilling and screwdriving at right angle to power tool.



You can engage the angle attachment in 16 different angle settings.

8.4 Tool holder in the drill spindle [7]

Bits can be inserted directly into the hexagon socket holder of the drill spindle.

9 Working with the machine

9.1 On/Off switch [1-6]

Press = ON, release = OFF



The speed of the machine depends on how far the on/off switch is pressed in.

9.2 LED lamp with capacity indicator

The LED bulb [1-11] lights up when the ON/OFF switch is pressed [1-6].

After releasing the ON/OFF switch [1-6] the capacity indicator on the LED lamp [1-11] displays the state of charge of the battery pack for a few seconds:

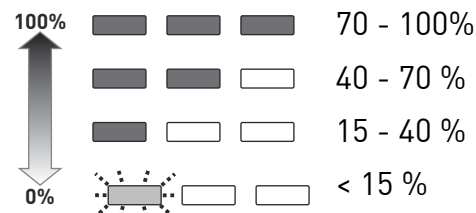

Recommendation:

Charge battery pack before further use.

9.3 Bit depot [1-10]

Magnetic, for storing bits and bit holders.

9.4 Warning signals

Power tool shuts down, capacity indicator flashes: Battery pack is empty.

- ▶ Change the battery pack.

Power tool shuts down, capacity indicator does not flash: Power tool is overheating or has been overloaded.

- ▶ Apply a lesser load to power tool.
- ▶ Allow power tool to cool down.

10 Service and maintenance



WARNING

Risk of injury, electric shock

- ▶ Always remove the battery pack from the power tool before performing any maintenance or service work.
- ▶ All maintenance and repair work which requires the motor housing to be opened should always be carried out by an authorised service workshop.



Customer service and repairs must only be carried out by the manufacturer or service workshops. Find the nearest address at: www.festool.co.uk/service

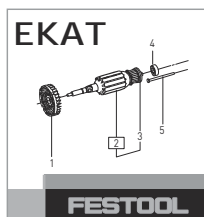

Always use original Festool spare parts. Order no. at: www.festool.co.uk/service

these must be observed. When preparing the item to be sent, a dangerous goods expert must be consulted. Only return the battery pack if it is undamaged. Observe local regulations when shipping. Observe any further national regulations.

Note the following information

- Keep the ventilation slits on the machine free and clean to ensure adequate cooling.
- Keep the contacts on the machine, charger and battery pack clean.

Information on battery packs

- Store in a cool, dry place at a temperature between 5 °C and 25 °C.
- Protect battery packs from moisture, water and heat.
- Do not leave empty battery packs in a charger disconnected from the mains power supply for longer than one month. Danger of deep discharge!
- If you intend to store li-ion battery packs for longer periods without use, you should charge them to 40 % capacity (approx. 15 min charging time).
- To avoid short circuits the battery pack should be stored in the packaging supplied.

11 Environment



Do not dispose of the device in the household waste! Recycle devices, accessories and packaging. Observe applicable national regulations.

EU only: In accordance with European Directive 2002/96/EC on waste electrical and electronic equipment and implementation in national law, used power tools must be collected separately and handed in for environmentally friendly recycling.

Information on REACH: www.festool.com/reach

12 Transportation

The Li-ion battery packs included are subject to the requirements of the legislation on hazardous goods. The user must familiarise themselves with the local regulations prior to transport. Special requirements apply to shipping via third parties (e.g. air transport or haulage) and