

MANN®

HOLZ

MASCHINEN

HOLZ BEARBEITUNG

DE **BEDIENUNGSANLEITUNG**

EN **USER MANUAL**

ES **MANUAL DE
INSTRUCCIONES**

FR **MODE D'EMPLOI**



DE **HOLZBANDSÄGE**

EN **WOOD BANDSAW**

ES **SIERRA DE CINTA**

FR **SCIE À RUBAN**

HBS 300J

HOLZMANN-MASCHINEN
Humer GmbH
A-4710 Grieskirchen, Schüsslberg 8
Tel 0043 (0) 7248 61116-0
Fax 0043 (0) 7248 61116-6

HOLZMANN-MASCHINEN
Schörghuber GmbH
A-4170 Haslach, Marktplatz 4
Tel 0043 (0) 7289 71562-0
Fax 0043 (0) 7289 71562-4

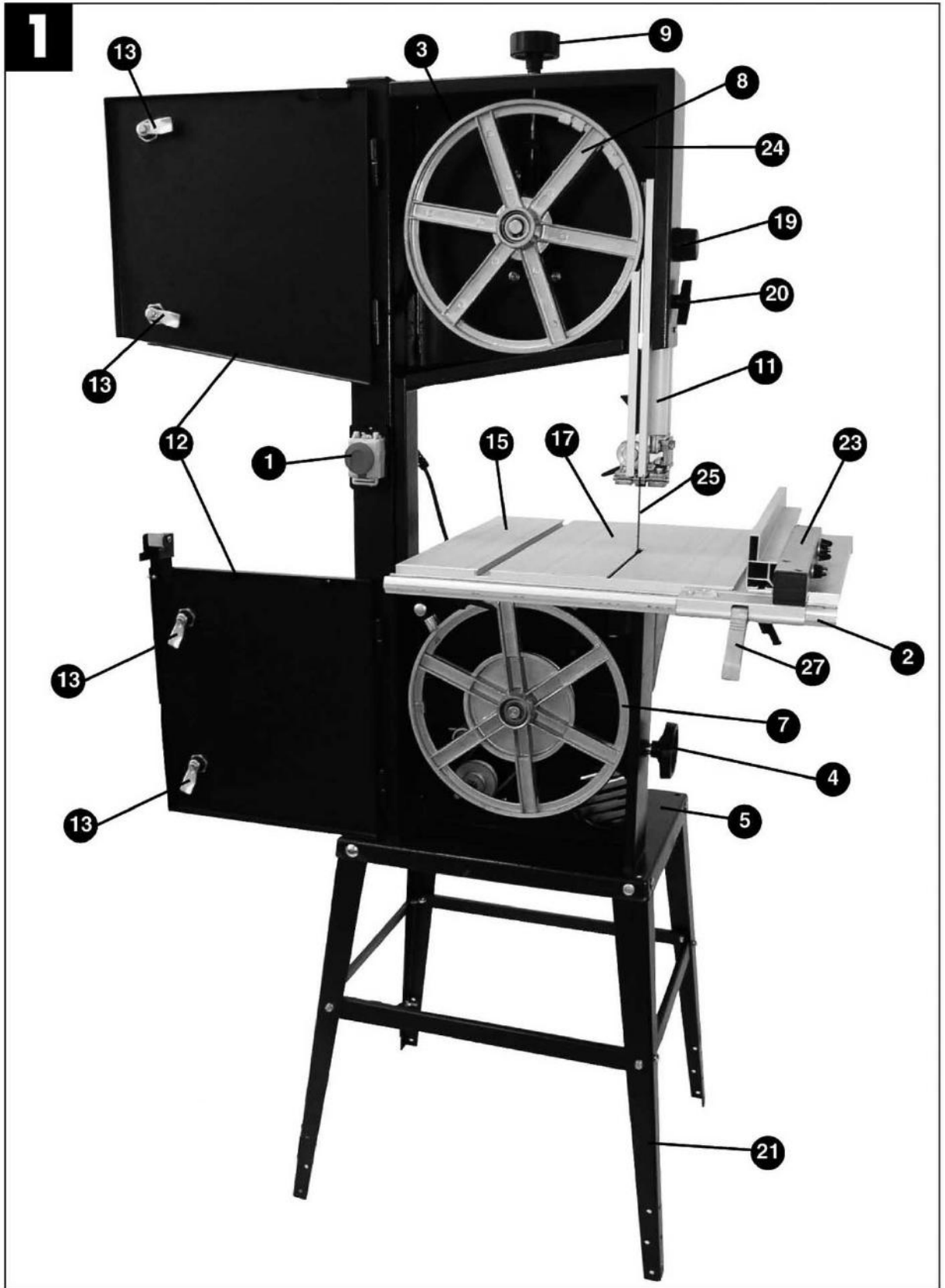

2

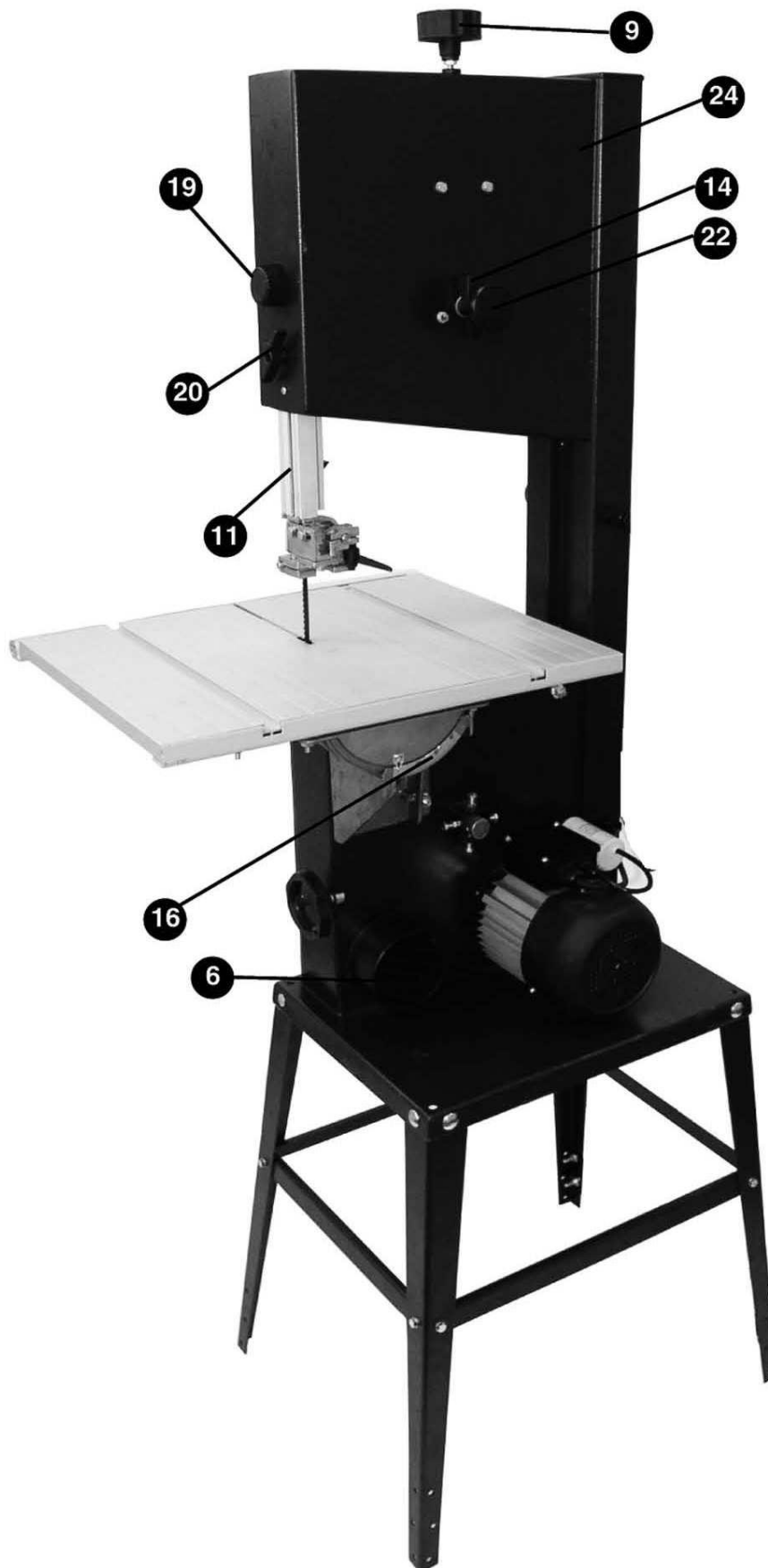

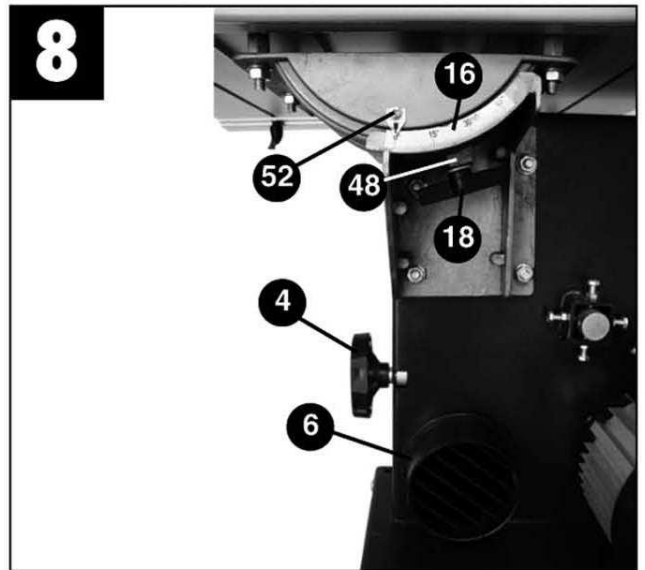
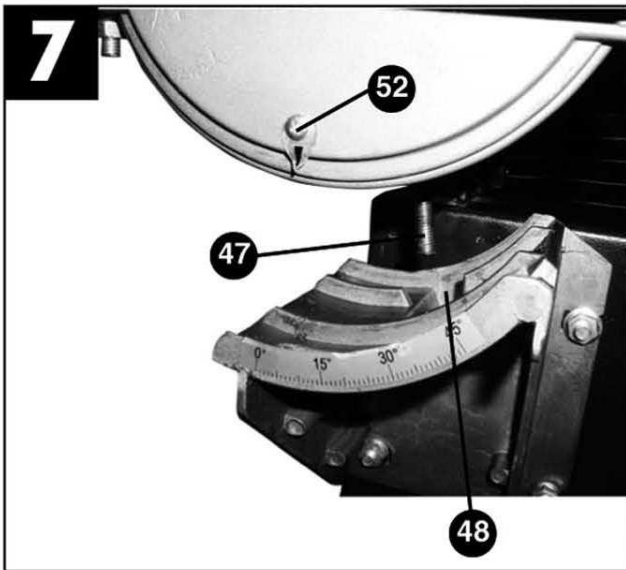
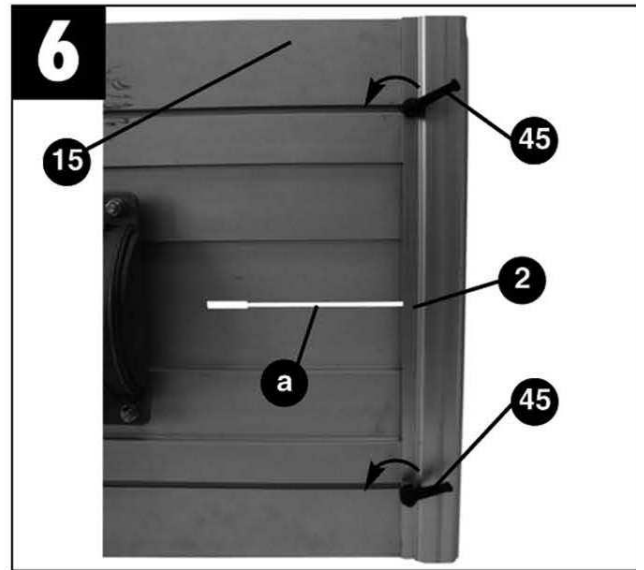
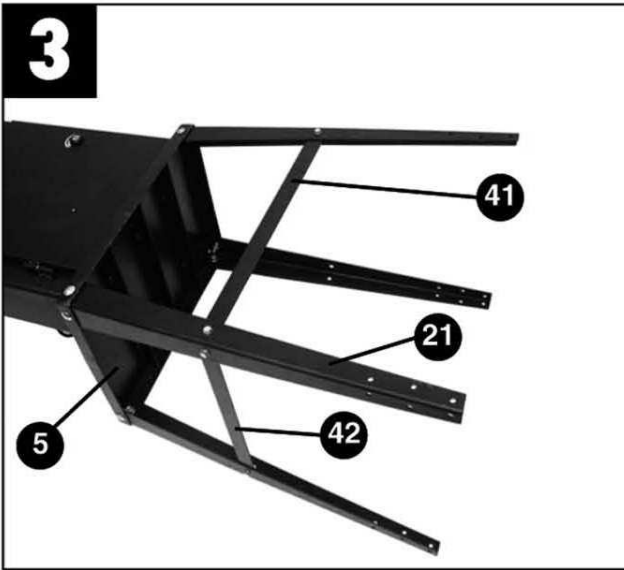

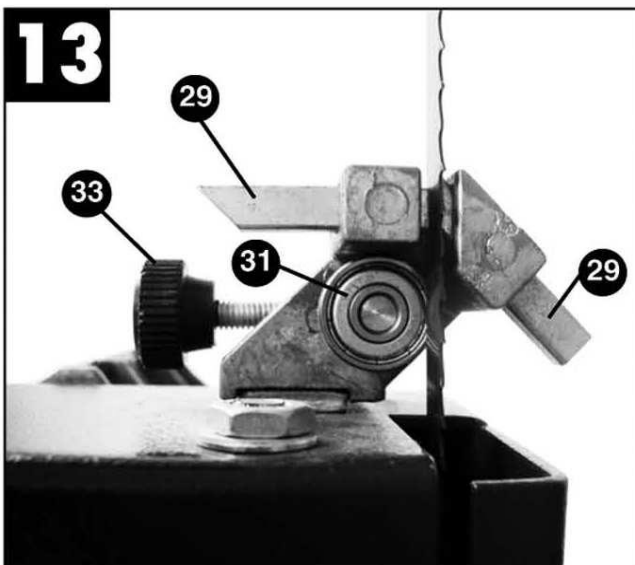
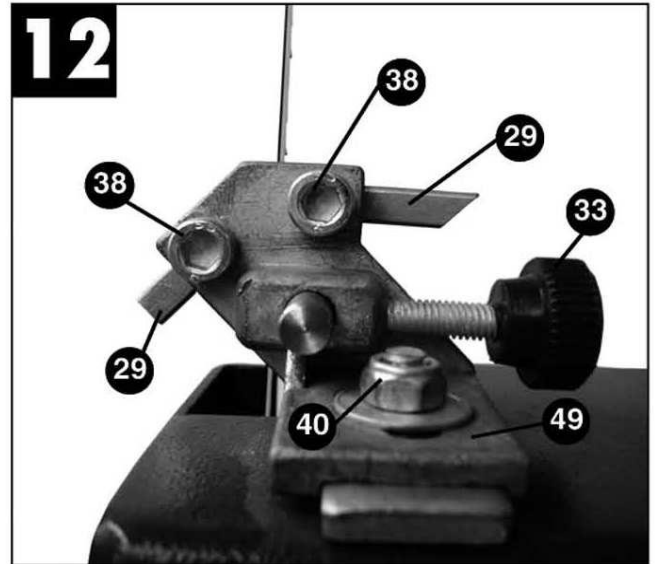
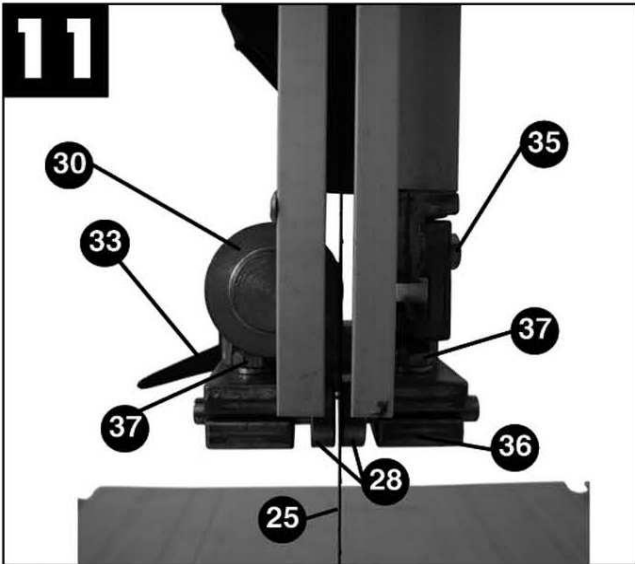
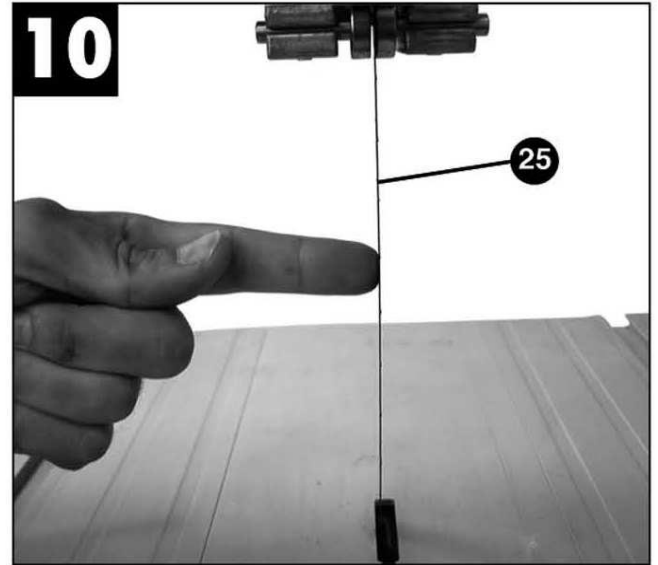
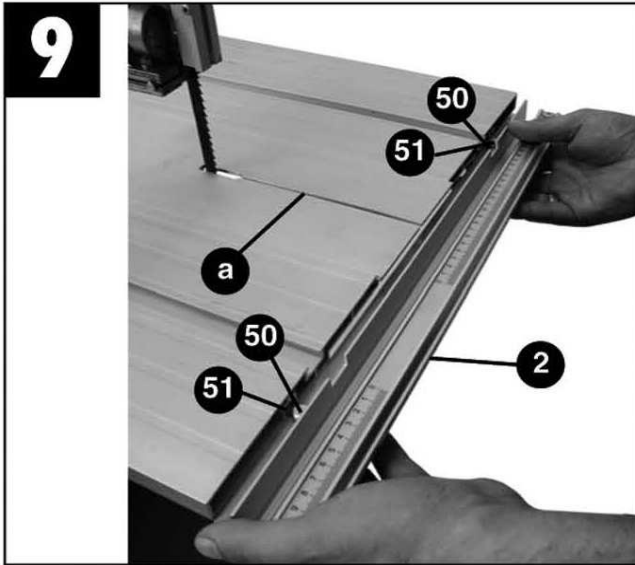

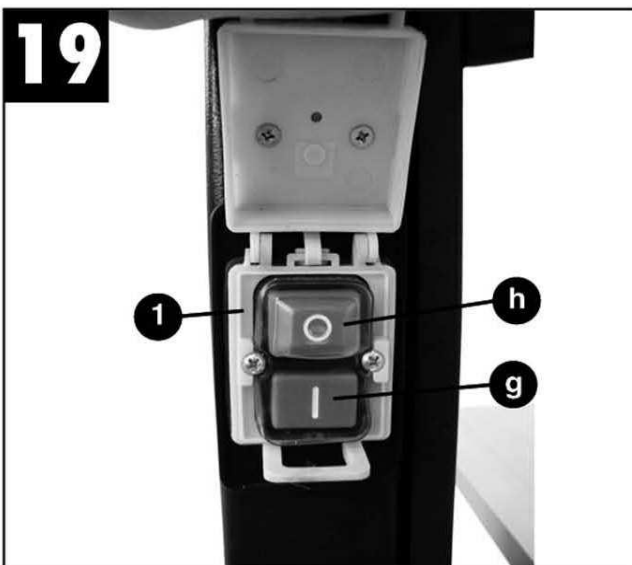
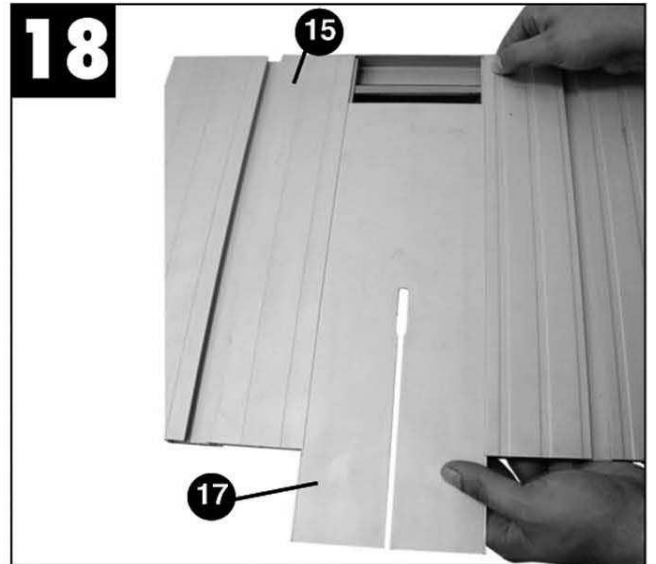
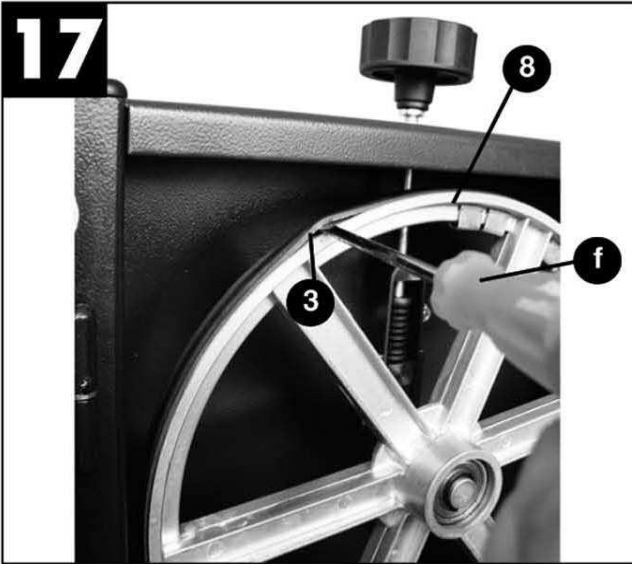
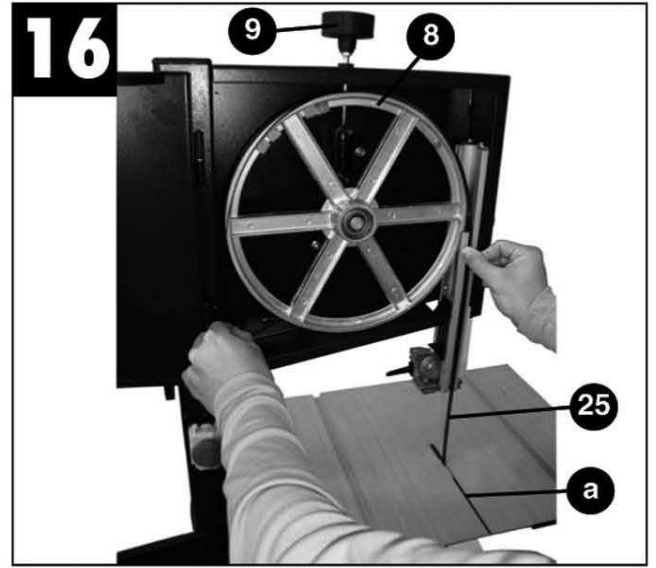
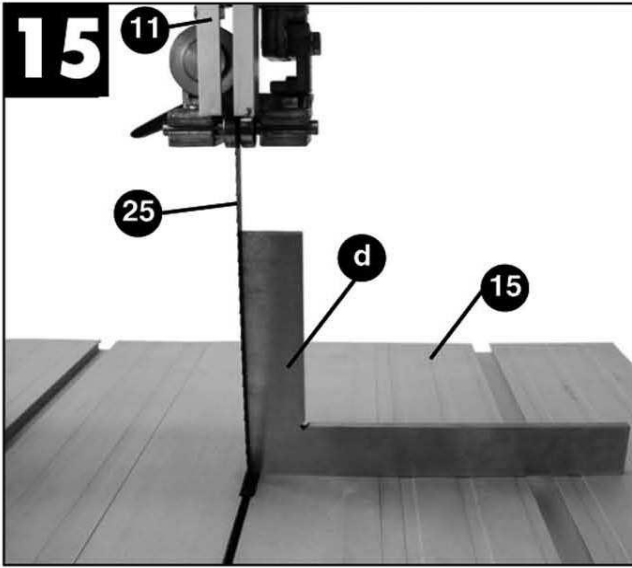

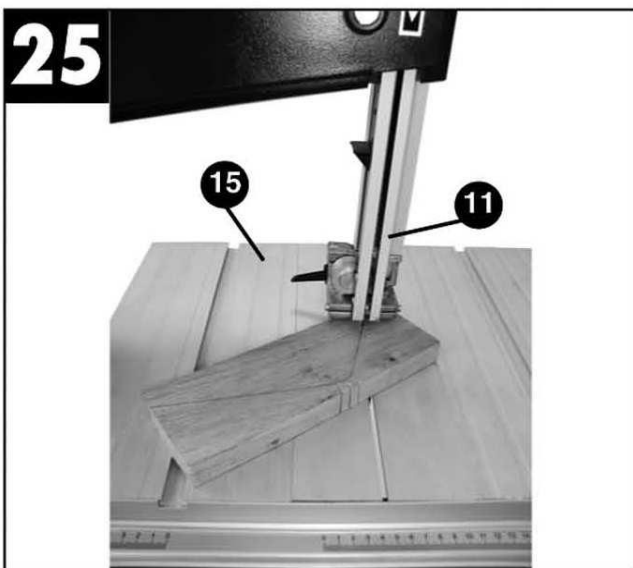
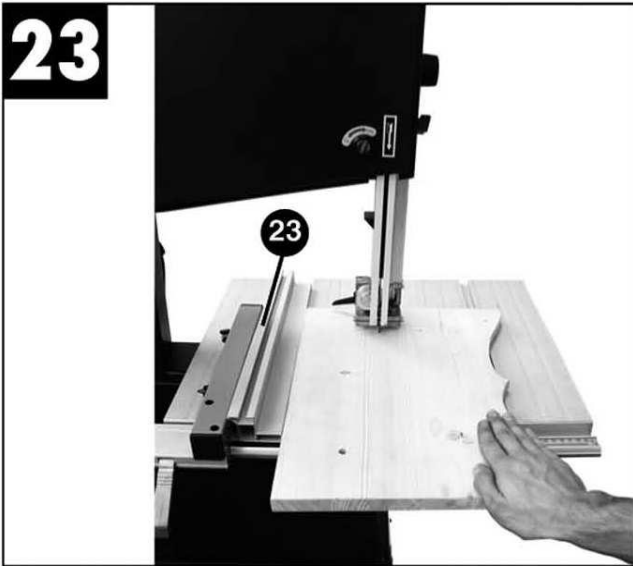
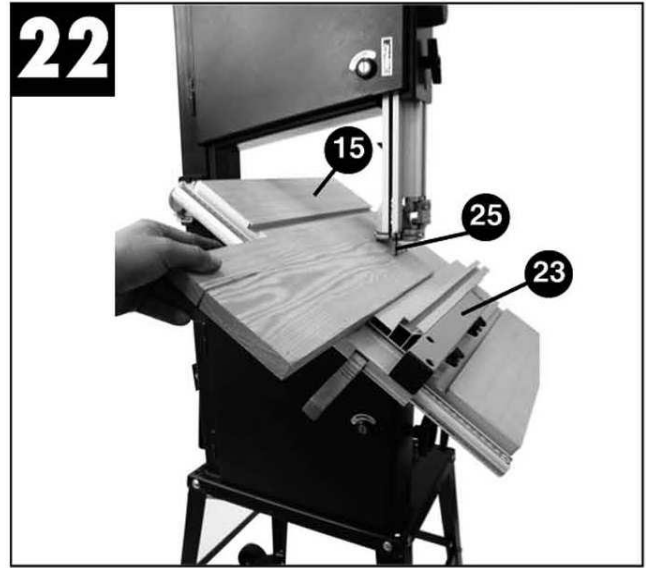
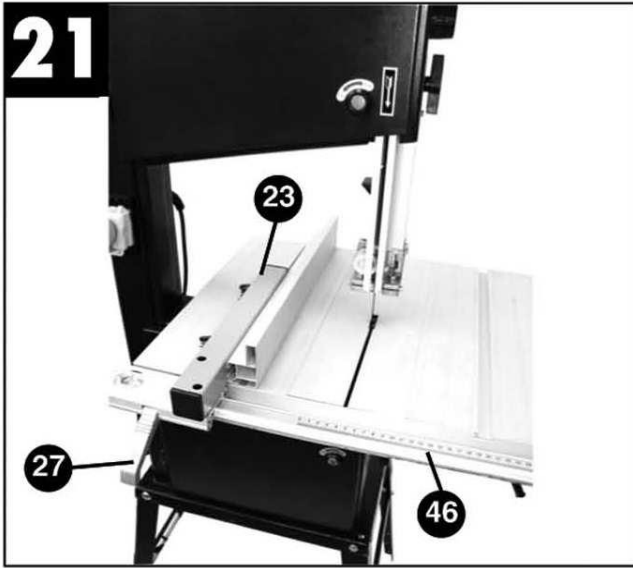

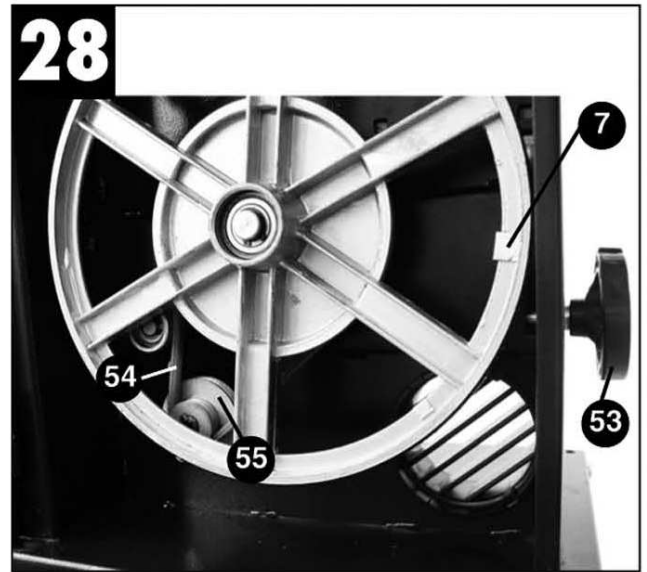

1. LAYOUT

- 1) On/Off Switch
- 2) Chain bar
- 3) Rubber tires
- 4) Hand wheel
- 5) Base plate
- 6) Dust extraction connector
- 7) Lower blade pulley
- 8) Upper blade pulley
- 9) Tightening screw
- 11) Upper blade guide
- 12) Side cover
- 13) Cover fastener
- 14) Retaining screw for upper blade pulley
- 15) Machine table
- 16) Dial scale for tilt angle
- 17) Table insert
- 18) Fixing handles for table
- 19) Adjustable handle for blade guide
- 20) Fixing handle for blade guide
- 21) Legs
- 22) Setting screw for upper blade pulley
- 23) Parallel stop
- 24) Machine frame
- 25) Blade

2. ITEMS SUPPLIED

- Bandsaw
- Machine table
- Push stick
- Parallel stop
- Base frame
- Blade

3. PROPER USE

The bandsaw is intended for the slitting and cross-cutting of timber or wood-like workpieces. Round materials may only be cut with suitable holding devices.

The machine is to be used only for its prescribed purpose.

Any other use is deemed to be a case of misuse. The user/operator and not the manufacturer will be held liable for damage

and/or injuries of any kind that result from such misuse. The machine is to be operated only with suitable saw blades. To use the machine properly you must also observe the safety regulations, the assembly instructions and the operating instructions to be found in this manual.

All persons who use and service the machine have to be acquainted with this manual and must be informed about the machine's potential hazard.

It is also imperative to observe the accident prevention regulations in force in your area.

The same applies for the general rules of health and safety at work.

HOLZMANN will not be liable for any changes made to the machine nor for any damage resulting from such changes.

Even when the machine is used as prescribed it is still impossible to eliminate certain residual risk factors. The following hazards may arise in connection with the machine's construction and design:

- Damage to hearing if ear-muffs are not used as necessary.
- Harmful emissions of wood dust when used in closed rooms.
- Contact with the blade in the uncovered cutting zone.
- Injuries (cuts) when changing the blade.
- Injury from catapulted workpieces or parts of workpieces.
- Crushed fingers.
- Kickback.
- Tilting of the workpiece due to inadequate support.
- Touching the blade.
- Catapulting of pieces of timber and workpieces.

4. IMPORTANT INFORMATION

SAFETY INFORMATION

CAUTION! Whenever you use electric tools it is imperative to take basic safety precautions in order to reduce the risk of fire, electric shock and personal injury. Essential safety precautions include:

- Keep your work area tidy! An untidy work area may cause accidents.

- Check the working conditions. Do not expose your bandsaw to rain. Never use it in damp or wet locations.
Make sure there is good lighting.
Do not use the bandsaw near flammable liquids or gases.
- Guard against electric shock! Avoid body contact with earthed components.
- Keep other persons away.
Do not allow other persons, particularly children, to touch the machine or the cable. Keep them away from your work area.
- Store tools in a safe place. When tools are not in use they should be stored in a dry, locked room out of children`s reach.
- Do not overload your machine. Your bandsaw works better and safer when used within their quoted capacity range.
- Use a machine with insufficient power for a job at hand. Never use your bandsaw for on jobs for which it was not intended.
- Wear suitable work clothes! Do not wear loose clothing or jewellery as they might get caught in moving parts. Wear a hair net if you have long hair.
- Use personal safety equipment: earmuffs, safety goggles, dust mask when working on dusty jobs.
- Connect the machine to a vacuum extraction system!
- Do not use the cable for purposes for which it is not designed.
- Avoid abnormal working postures! Make sure you stand squarely and keep balance at all times.
- Always pull out the power plug:
When the machine is not being used, plug it out.
- Remove adjusting keys, wrenches and other tools from the working table after use.
- Always stay focused when working. Reduce distortion sources in your working environment.
- Check the ON/OFF Switch periodically.
- Have repairs carried out only by a qualified electrician. Have your power connection checked by a qualified electrician.
- Wear safety gloves whenever you carry out any maintenance work on the blade.
- In the case of mitre cuts the parallel guide must be placed at the lower place of the working table to hold the workpiece.
- A dust collecting system with a minimum air velocity of 20m/min shall be connected to the bandsaw.
- Give this operation manual to every person who works with the machine.
- DO NOT USE THIS SAW TO CUT FIREWOOD.
- The machine is equipped with a safety switch to prevent it being switched on again accidentally after a power failure.
- Never dismantle the machine`s safety devices or render them infunfunctional.
- Let unreadable safety stickers be replaced immediately.
- Never cut workpieces that are too small to be guided securely by your hand or pushstick.
- Never remove loose splinters, chips or jammed pieces of wood when the saw blade is running.
- It is imperative to observe the accident prevention regulations in force in your country as well as all other generally recognized rules of safety.
- Position the blade guard so that it is approx. 3mm above the material you want to saw.
- Secure long workpieces against falling off at the end of the cut with a roller table.
- Make sure the blade guard is in its lowest position when the machine is being transported.
- Blades that are deformed or damaged have to be replaced immediately.
- Worn table inserts have to be replaced immediately.
- Never start the machine when the door protecting the blade is open.
- Do not touch the blade until it has come to a complete stop.
- IMPORTANT: THIS BANDSAW IS INTENDED ONLY FOR HOME AND DO-IT-YOURSELF HOBBY USE. THE MACHINE IS NOT DESIGNED FOR PROFESSIONAL USE.

5. TECHNICAL DATA HBS 300J

Voltage	230V/400V ~ 50Hz
Power	750W
Idle run speed n_o	1400 min⁻¹
Blade length	2240mm
Blade width	6-18mm
Blade speed	360/720 m/min
Cutting height 90°	170mm
Cutting height 45°	70mm
Table size	500 x 400mm
Tilting range	90° - 45°
Max. workpiece size	600 x 600mm
weight	83kg

Nose emission values:

L_{PA} sound pressure level 92,7dB(A)

L_{WA} sound power level 102,3dB(A)

6. BEFORE STARTING THE MACHINE

- Make sure the machine stands securely, i.e. bolt it to a workbench or solid base. Fixing holes are provided in the base plate for this purpose.
- The saw table must be correctly assembled.
- All covers and safety devices have to be properly fitted before the machine is switched on.
- It must be possible for the blade to run freely.
- When working with wood that has been processed before, watch out for foreign bodies such as nails or screws etc,
- Before you actuate the On/off switch, make sure that the saw blade is correctly fitted and that the machine`s moving parts run smoothly.
- Check that the voltage on the rating plate is the same as your supply voltage before you connect to the power supply.

7. ASSEMBLY

CAUTION! Pull out the power plug before carrying out any maintenance, assembly, resetting work on the machine!

7.1 Assembly of the sub-frame and wheels (Fig. 3-5/27)

- First attach the legs (21) loosely to the base plate (5) of the machine using 2 screws for each leg. Use the round head M8x12 screws to do so.
- Screw the 2 long struts (41) and the 2 short struts (42) loosely to the legs (21). The doubled-over part of the struts must be at the top.
- Attach the rubber feet to the legs (21).
- Place the machine onto the legs
- Align the entire base frame and tighten all screws.
- Fasten the holder (29) for the push stock (28) as follows: Screw the lock nut onto the bolt (29) and then screw this into the housing until the push stick (28) can be hung up.

7.2 Assembling the saw table (Figures 6-9)

- Slacken the wing nuts (45) on the underside of the saw table (15) and remove the chain bar (2) from the saw table.
- Lead the blade through the slot (a) in the machine table and place the machine table on the table guide so that the clamping screw (47) fits through the mounting (48).
- Screw the saw table tight with the wing nut (18).
- Place the chain bar (2) onto the saw table (15) so that the screw heads (50) slide into the guide slots (51).
- Check that the blade (25) runs freely and does not touch the saw blade.
- To remove the saw blade guard, proceed in reverse order.

7.3 Tensioning the blade

- **CAUTION!** Remove the tension from the blade if the bandsaw is not going to be used for some time. Be sure to re-tension the blade before you start the machine.
- Turn the tightening screw (9) for tensioning the blade (25) in a clockwise direction.
- The correct blade tension can be checked by applying pressure to the side of the blade with your finger, somewhere in the middle between the two blade pulleys (7+8). You should only be able to bend the blade (25) very slightly (approx. 1-2mm).
- **CAUTION!** The blade may break if the tension is too high. **BEWARE IF INJURY!** If the tension is too low, the powered blade pulley (7) will spin while the blade does not move.

7.4 Adjusting the blade

- Undo the fasteners (13) and open the side cover (12).
- Turn the upper blade pulley (8) slowly in a clockwise direction. The blade (25) should run centrally on the blade pulley (8). If it does not, the angle at which the upper blade pulley (8) tilts must be adjusted.
- If the blade (25) runs more towards the rear of the blade pulley (8), i.e. towards the machine housing (24), the setting screw (22) must be turned in an anticlockwise direction. Then turn the blade pulley (8) slowly with the other hand to check the position of the blade.
- If the blade (25) runs towards the front edge of the belt pulley (8), the setting screw (22) must be turned in a clockwise direction.
- After adjusting the upper blade pulley (8), check the position of the blade (25) on the lower blade pulley (7). Again, the blade (25) should run in the middle of the blade pulley (7). When adjusting the upper blade pulley you have to turn it several times until the adjustment has an effect on the position of the blade on the lower blade pulley.

- When adjustment has been completed, close the side cover (12) again and secure it with the fasteners (13).

7.5 Adjusting the blade guide (Fig. 11-13)

Whenever you change the blade you must reset both the support bearings (30+31) and the guide pins (28+29).

7.5.1 Upper support bearing (Fig. 11)

- Undo the screw (33).
- Move the support bearing (30) s that it is almost touching the blade (25). There should be a gap of approx. 0,5mm.
- Re-tighten the screw.

7.5.2 Setting the lower support bearing (31)

- Disassemble the saw blade (15).
- Adjust in the same way that the upper support bearing was adjusted.
- The blade (25) is only supported by the support bearings (30+31) during cutting. During idle run the blade should not touch the ball bearings.

7.5.3 Setting the upper guide bearings (Figure 11)

- Undo the screw (35).
- Move the mount (36) of the guide bearings (28) so that there is a gap of approx. 1mm between the front edge of the guide bearings (28) and the gullet of the blade in front.
- Re-tighten the screw (35)
- **CAUTION!** The blade will be rendered useless if the teeth touch the guide bearings while the blade is running.
- Undo the screws (37)
- Move the two guide bearings (28) towards the blade so that there is a gap of approx. 0,5mm between the guide bearings (28) and the blade (25).
- Re-tighten the screws (37).

- Turn the upper blade pulley (8) several times in a clockwise direction.
- Check the setting of the guide bearings (28) again and re-adjust if necessary.

7.5.4 Setting the lower guide bearings (29) (Fig. 12/13)

- Disassemble the saw table (15) (see 7.2)
- Undo the screw (40)
- Move the mount of the guide pins (29) so that there is a gap of approx. 1mm between the front edge of the pins (29) and the gullet of the blade in front.
- Re-tighten the screw (40).
- **CAUTION!** The blade will be rendered useless if the teeth touch the guide pins while the blade is running.
- Undo the screws (38).
- Move the guide pins (29) towards the blade so that there is a gap of max. 0,5mm between the guide pins (29) and the blade (25). (The blade must not jam).
- Re-tighten the Allen screws (38).
- Turn the lower blade pulley (7) several times in a clockwise direction.
- Check the setting of the guide pins (29) again and re-adjust if necessary.

7.6 Adjusting the upper blade guide (11) (Fig. 2/14)

- Undo the fixing handle (20).
- Turn the adjustment wheel (19) to lower the blade guide (11) as close as possible to the workpiece to be cut (the gap should be approx. 2-3mm).
- Re-tighten the fixing handle (20).
- Check the setting before each cut and re-adjust if necessary.

7.7 Adjusting the saw table (15) to 90° (8/15)

- Move the upper blade guide (11) to the top.
- Undo the fixing handles (18).
- Set the angle (d) between the blade (25) and the table (15).

- Tilt the table (15) by turning it so that the angle between it and the blade (25) is precisely 90°.
- Re-tighten the fixing handles (18).
- Undo the screw (52) of the pointer of the dial scale (16), set the pointer to exactly 0° and tighten the screw (52) again.

7.8 Blade selection

The blade supplied with the bandsaw is designed for all-purpose use. When you select a blade you should have regard to the following criteria:

- Use a narrow blade to cut tighter radii than you can with a wider blade.
- Wide blades are used to saw straight cuts. This is particularly important in cutting wood because the blade has a tendency to follow the grain of the wood and thereby deviate easily from the cutting line.
- Finely toothed blades provide smoother cuts but are slower than coarse blades.

IMPORTANT: Never use warped or lacerated blades!

7.9 Replacing the blade (Figure 16)

- Move the blade guide (11) into a position approximately half way between the table (15) and the machine frame (24).
- Undo the fasteners (13) and open the side cover (12).
- Remove the chain bar (2).
- Turn the tightening screw (9) anti-clockwise to remove the tension from the blade (25).
- Remove the blade (25) from the blade pulleys (7,8) and take out through the slot in the table (15).
- Fit the new blade (25), aligned centrally on the blade pulleys (7,8).
- The teeth of the blade (25) must point downwards in the direction of the table.
- Tension the blade (25) (see 7.2)
- Close the side cover (12) again.
- Mount the web panel (4) again.

7.10 Changing the rubber tires on the blade pulleys (Fig. 17)

After a certain time the rubber tires (3) on the blade pulleys (7,8) will get worn by the sharp teeth of the blades and must be replaced.

- Open the side cover (12).
- Remove the blade (25) (see 7.7)
- Lift the edge of the tire (3) with a small screwdriver (f) and remove it from the blade pulley (8).
- Repeat for the lower blade pulley (7).
- Fit the new rubber tire (3), mount the blade (25) and close the side cover (12) again.

7.11 Changing the table insert (Fig. 18)

To prevent increased likelihood of injury the table insert (17) should be changed whenever it is worn or damaged.

- Dismantle the saw table (15) (see 7.2).
- Push out the worn table insert (17).
- Fit the replacement table insert by following the above in reverse.

7.12 Extractor port

The bandsaw is equipped with an 100mm extractor socket (6) for extracting sawdust and chips.

7.13 Adjusting the blade speed (Fig. 28)

The bandsaw can be operated at two blade speeds. To change the position proceed as follows:

- Slacken the drive belt (54) by turning the hand wheel (4) in an anticlockwise direction.
- Move the belt to the desired position on the belt pulley (55) and the lower blade pulley (7). The blade speeds are indicated on the inside of the side cover.
- Tension the drive belt (54) again by turning the hand wheel (4) in a clockwise direction. Important: Drive belts must not be tensioned too much!

8. OPERATION

8.1 ON/OFF switch (Fig. 19)

- To turn the saw on, press the green button (g).
- To turn the saw off again, press the red button (h).

Your bandsaw has a switch with undervoltage release. After a power failure you must reactivate the switch

8.2 Parallel stop (Fig. 20/21)

The parallel stop is used as a guide in slitting.

- Place the parallel stop (23) onto the chain bar (2) on the left or right and set the desired dimension.
- Clamp the parallel stop in the desired position by pressing the clamping lever (27)
- The chain bar can be used for thinner workpieces as shown in Figure 20 and for thicker workpieces as shown in Figure 21.

8.3 Angular cuts (Figure 8/22)

To enable you to perform angular cuts parallel to the blade (25), the table (15) can be tilted forwards between 0° -45°.

- Undo the fixing handle (18).
- Tilt the saw table (15) forward until required angle value has been set on the man scale (16).
- Re-tighten the fixing handle (18).
- Important: When the table (15) is tilted, place the parallel stop (23) to the right of the blade (25) looking in the direction in which you are working, on the side pointing downwards. (provided the workpiece is wide enough) in order to stop the workpiece from slipping off.

9. OPERATION ADVICES

Important! After every new adjustment we recommend you to make a trial cut in order to check the new settings.

- For all cutting operations it is important to position the blade guide (11) as close as possible to the workpiece.
- Always guide the workpiece with both hands, holding it flat on the table (15) in order to prevent the blade (25) from jamming.
- Feed the workpiece at a uniform speed that enables the blade to cut through the material without difficulty and without blocking.
- Always aim at making a complete cut in one pass rather than in a stop-and-go operation requiring the workpiece to be withdrawn. If you have to withdraw the workpiece, switch off the bandsaw first and wait for the blade (25) to stop before freeing the workpiece.
- The workpiece must always be guided by the longer side during cutting.

Important! When handling narrower workpieces, it is essential to use a push stick. The push stick (28) must always be kept close at hand at then hook(29) provided for that purpose on the side of the saw (Fig. 27).

9.1 Longitudinal cuts

Longitudinal cutting (also known as slitting) is when you use the saw to cut along the grain of the wood.

- Place the parallel stop (23) to the left of the blade (25), as far as possible, for the width required.
- Lower the blade guide (11) down to the workpiece.
- Switch the saw on.
- Press the edge of the workpiece with your right hand to hold it securely against the parallel stop (23) and flat on the table (15).
- Guide the workpiece along the parallel stop (23) and through the blade (25) at a uniform speed.

- Important: Long workpieces must be secured against falling off the table at the end of the cut-

9.2 Freehanded cuts (Figure 25)

One of the most outstanding features of a bandsaw is the ease with which it allows you to make curved cuts and radii.

- Lower the blade guide (11) down to the workpiece.
- Switch on the saw.
- Hold the workpiece securely on the table (15) and guide slowly through the blade (25).
- Freehanded cuts should be made at low feed speed so that you can guide the blade (25) along the required line.
- It often pays to first cut off surplus curves and corners up to about 6mm from the cutting line.
- In the case of curves which are too tight for the blade to cut correctly, it can help to make a series of close-lying cuts at right angles to the curved line. When you saw the radius the material simply will drop off.

10. MAINTENANCE

Important! Pull out the power plug first.

Remove the dust and dirt regularly from the machine. Cleaning is best carried out with a fine brush or a cloth.

Never use caustic agents to clean plastic parts.

11. ORDERING SPARE PARTS

Please provide the following information on all orders for spare parts:

- Model/type of the machine
- Date of acquisition
- Serial number of the machine
- Spare part(s) marked on exploded drawing
- Required spare part numbers listed additionally.

12 KONFORMITÄTSERKLÄRUNG / CERTIFICATE OF CONFORMITY

	Inverkehrbringer / Distributor HOLZMANN MASCHINEN® AUSTRIA Schörgenhuber GmbH A-4170 Haslach, Marktplatz 4 Tel.: +43/7289/71562-0; Fax.: +43/7289/71562-4 www.holzmann-maschinen.at
Bezeichnung / Name	
Holzbandsäge HBS 300J	
Type(n) / Model(s)	
HOLZMANN HBS 300J (JFB12), 220-240V, 50Hz, 750W, IP 20;	
EG-Richtlinie(n) / EC-Directive(s)	
98/37/EG Maschinenrichtlinie / Machinery Directive 2004/108/EC Richtlinie elektromagn. Verträglichkeit / EMC directive	
Berichtsnummer(n) / Test Report Number(s)	
704030800911-03 708880800911-02	
Registrierungsnummer(n) / Registration Number(s)	
M6T 09 12 44390 540 E8N 09 03 44390 451	
getestet nach / tested according to	
Art. 8(2), 8(2)c EN55014-1:2006, EN55014-2/A1:2001, EN61000-3-2:2006, EN61000-3-3/A2:2005	
Ausstellungsdatum / Issuing Date	
03.12.2009 / 2009-12-03 02.04.2009 / 2009-04-02	
Ausstellungsbehörde / Issuing Authority	
TÜV SÜD Product Service GmbH ♦ Zertifizierstelle ♦ Ridlerstrasse 65 ♦ 80339 München ♦ DE TÜV SÜD Product Service GmbH ♦ Zertifizierstelle ♦ Ridlerstrasse 65 ♦ 80339 München ♦ DE	

Hiermit erklären wir, dass genannte(n) Maschine(n) den oben genannten Sicherheits- und Gesundheitsrichtlinien der EG entsprechen. Diese Erklärung verliert ihre Gültigkeit, wenn Veränderungen an der Maschine vorgenommen werden, die nicht mit uns abgestimmt wurden.

Hereby we declare that the mentioned machines fulfil the above stated EC-Directives. Any manipulation of the machines not authorized by us renders this document invalid.



Haslach, 10.02.2012	Klaus Schörgenhuber, CEO 
Ort/place, Datum/date	
Unterschrift / sign	