

JET

719-A
719-AS

MORTISER

Original:
GB
Operating Instructions

Translations:
D
Gebrauchsanleitung

F
Mode d'emploi

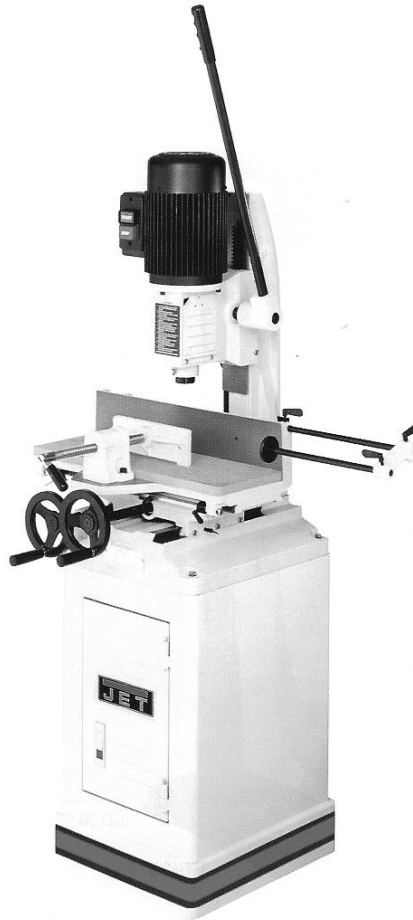

Walter Meier (Tool) AG
Tämperlistrasse 5
CH-8117 Fällanden
Switzerland
Phone +41 44 806 47 48
Fax +41 44 806 47 58
jetinfo.eu@waltermeier.com
www.jettools.com



CE-Conformity Declaration

Product: Mortiser

719A

Stock Number: 1791263M

719AS

Stock Number: 708572KM

Brand: JET

Manufacturer:

Walter Meier (Tool) AG, Tämperlistrasse 5, CH-8117 Fällanden, Switzerland

On our own responsibility we hereby declare that this product complies
with the regulations

- * 2006/42/EC Machinery Directive
- * 2004/108/EC EMC Directive (Electro Magnetic Compatibility)
- * 2006/95/EC Low Voltage Directive
- * 2002/95/EC RoHS Directive (Reduction of Hazardous Substances)

designed in consideration of the standards

** EN ISO 12100-1, EN ISO 12100-2, EN ISO 13857, EN 349, EN 953,
EN 60204-1, EN ISO 11202, EN 55014-1, EN 55014-2, EN ISO 14121-1

Technical file compiled by: Hansjörg Brunner, Product Management



2011-01-25 Eduard Schärer, General Manager

Walter Meier (Tool) AG, Tämperlistrasse 5, CH-8117 Fällanden, Switzerland

GB - ENGLISH

Operating Instructions

Dear Customer,

Many thanks for the confidence you have shown in us with the purchase of your new JET-machine. This manual has been prepared for the owner and operators of a JET 719-A mortiser to promote safety during installation, operation and maintenance procedures. Please read and understand the information contained in these operating instructions and the accompanying documents. To obtain maximum life and efficiency from your machine, and to use the machine safely, read this manual thoroughly and follow instructions carefully.

...Table of Contents

1. Declaration of conformity

2. JET Warranty

3. Safety

Authorized use

General safety notes

Remaining hazards

4. Machine specifications

Technical data

Noise emission

Contents of delivery

5. Transport and start up

Transport and installation

Assembly

Mains connection

Dust collection

Starting operation

6. Machine operation

7. Setup and adjustments

Installing chisel and bit

Sharpening chisel and bit

8. Maintenance and inspection

9. Trouble shooting

10. Available accessories

1. Declaration of conformity

On our own responsibility we hereby declare that this product complies with the regulations* listed on page 2. Designed in consideration with the standards**.

2. JET Group Warranty

The JET Group makes every effort to assure that its products meet high quality and durability standards and warrants to the original retail consumer/purchaser of our products that each product be free from defects in materials and workmanship as follows:

2 YEAR LIMITED WARRANTY ON ALL PRODUCTS UNLESS SPECIFIED OTHERWISE.

This Warranty does not apply to defects due to directly or indirectly misuse, abuse, negligence or accidents, normal wear-and-tear, repair or alterations outside our facilities, or to a lack of maintenance.

The Jet group limits all implied warranties to the period specified above, from the date the product was purchased at retail.

To take advantage of this warranty, the product or part must be returned for examination, postage prepaid, to an authorized repair station designated by our office.

Proof of purchase date and an explanation of the complaint must accompany the merchandise.

If our inspection discloses a defect, we will either repair or replace the product, or refund the purchase price if we cannot readily and quickly provide a repair or replacement, if you are willing to accept a refund.

We will return repaired product or replacement at JET'S expense, but if it is determined there is no defect, or that the defect resulted from causes not within the scope of JET'S warranty, then the user must bear the cost of storing and returning the product.

The JET Group reserves the right to make alterations to parts, fittings, and accessory equipment which they may deem necessary for any reason whatsoever.

3. Safety

3.1 Authorized use

This mortiser is designed for mortising wood and similar materials only. Machining of other materials is not permitted and may be carried out in specific cases only after consulting with the manufacturer.

The proper use also includes compliance with the operating and maintenance instructions given in this manual.

The machine must be operated only by persons familiar with its operation and maintenance and who are familiar with its hazards.

The required minimum age must be observed.

The machine must only be used in a technically perfect condition.

When working on the machine, all safety mechanisms and covers must be mounted.

In addition to the safety requirements contained in these operating instructions and your country's applicable regulations, you should observe the generally recognized technical rules concerning the operation of woodworking machines.

Any other use exceeds authorization. In the event of unauthorized use of the machine, the manufacturer renounces all liability and the responsibility is transferred exclusively to the operator.

3.2 General safety notes

Woodworking machines can be dangerous if not used properly. Therefore the appropriate general technical rules as well as the following notes must be observed.

Read and understand the entire instruction manual before attempting assembly or operation.

Keep this operating instruction close by the machine, protected from dirt and humidity, and pass it over to the new owner if you part with the tool.

No changes to the machine may be made.

Daily inspect the function and existence of the safety appliances before you start the machine. Do not attempt operation in this case, protect the machine by unplugging the power cord.

Remove all loose clothing and confine long hair.

Before operating the machine, remove tie, rings, watches, other jewellery, and roll up sleeves above the elbows.

Wear safety shoes; never wear leisure shoes or sandals.

Always wear the approved working outfit.

Do **not** wear gloves.

Wear goggles when working

Install the machine so that there is sufficient space for safe operation and workpiece handling.

Keep work area well lit.

The machine is designed to operate in closed rooms and must be bolted stable on firm and levelled table surface or on the supplied cabinet stand.

Make sure that the power cord does not impede work and cause people to trip.

Keep the floor around the machine clean and free of scrap material, oil and grease.

Stay alert!

Give your work undivided attention. Use common sense. Do not operate the machine when you are tired.

Do not operate the machine under the influence of drugs, alcohol or any medication. Be aware that medication can change your behaviour.

Never reach into the machine while it is operating or running down.

Never leave a running machine unattended. Before you leave the workplace switch off the machine.

Keep children and visitors a safe distance from the work area.

Do not operate the electric tool near inflammable liquids or gases. Observe the fire fighting and fire alert options, for example the fire extinguisher operation and place.

Do not use the machine in a dump environment and do not expose it to rain.

Before machining, remove any nails and other foreign bodies from the workpiece.

Work only with well sharpened tools.

Machine only stock which rests securely on the table.

Always close the chuck cover before you start the machine.

Specifications regarding the maximum or minimum size of the workpiece must be observed.

Do not remove chips and workpiece parts until the machine is at a standstill.

Do not stand on the machine.

Connection and repair work on the electrical installation may be carried out by a qualified electrician only.

Have a damaged or worn power cord replaced immediately.

Make all machine adjustments or maintenance with the machine unplugged from the power source.

3.3 Remaining hazards

When using the machine according to regulations some remaining hazards may still exist.

The rotating drill bit can cause injury.

Thrown workpieces and workpiece parts can lead to injury.

Dust and noise can be health hazards. Be sure to wear personal protection gear such as safety goggles and dust mask. Use a suitable dust collection system.

The use of incorrect mains supply or a damaged power cord can lead to injuries caused by electricity.

4. Machine specifications

4.1 Technical data

Motor speed	1450 rpm
Drill chuck capacity	13mm
Chisel capacity	25 x 25mm
Chisel bushings	5/8", 3/4", 13/16", 1"
Head stroke	200mm
Fence size	90 x 520mm
Chisel centre to fence max	100mm
Table size	180 x 520mm
Table movement long-ways	400mm
Table movement cross-ways	100mm
Maximum vertical distance table to chisel bushing	295mm
Net weight	125 kg
Mains	230V ~1/N/PE 50Hz
Output power	0,75 kW (1 HP) S1
Reference current	6 A
Extension cord (H07RN-F):	3x1,5 ²
Installation fuse protection	10A

4.2 Noise emission

Acoustic pressure level (EN 11202):

Idling	67,8 dB (A)
In operation	77,5 dB (A)

The specified values are emission levels and are not necessarily to be seen as safe operating levels.

As workplace conditions vary, this information is intended to allow the user to make a better estimation of the hazards and risks involved only.

4.3 Content of delivery

Cabinet stand
13mm drill chuck
Chuck key
Spindle extension
5/8" (15,87mm) chisel bushing
3/4" (19,05mm) chisel bushing
13/16" (20,64mm) chisel bushing
1" (25,4mm) chisel bushing
2 handwheel handles
MDF table
Operating handle
work stop
Operating tools
Assembly kit
Operating manual
Spare parts list.

5. Transport and start up

5.1 Transport and installation

The machine is designed to operate in closed rooms and must be bolted on a firm and levelled table surface or on the original cabinet stand.

5.2 Assembly

If you notice transport damage while unpacking, notify your supplier immediately. Do not operate the machine!

Dispose of the packing in an environmentally friendly manner.

Clean all rust protected surfaces with a mild solvent.

Screw the handle (A, Fig1) into the pinion shaft and tighten.

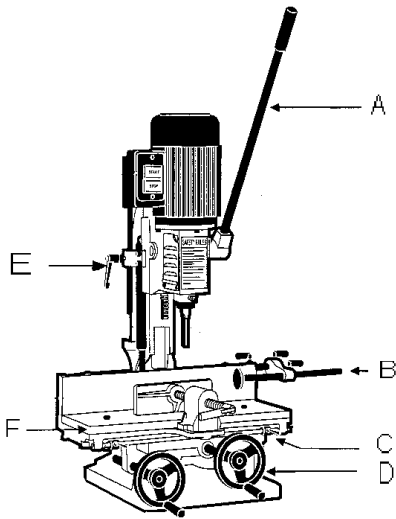

Fig 1

Use the handle to raise the machine head to the up position. The handle is spring loaded and can be repositioned by pulling the handle away from the head, and turned to the desired angle.

Attach the MDF table (F, Fig1) to the base using two screws.

Attach the work stop (B, Fig1).

The work stop can be mounted on either end of the table.

Attach the handles to the handwheels (D, Fig1).

Adjust the depth stop (E, Fig1) and the table stops (C, Fig1) according to the work to be performed.

5.3 Mains connection

Mains connection and any extension cords used must comply with applicable regulations.

The mains voltage must comply with the information on the machine licence plate.

The mains connection must have a 10 A surge-proof fuse.

Only use power cords marked H07RN-F

Connections and repairs to the electrical equipment may only be carried out by qualified electricians.

5.4 Dust collection

Use a suitable dust collection and filtration system to avoid a high dust concentration in the air.

Dust the machine down after each use and as necessary.

5.5 Starting operation

You can start the machine with the green on button. The red button on the main switch stops the machine.

6. Machine operation

Set the depth stop rod (A, Fig2) to the required depth of cut.

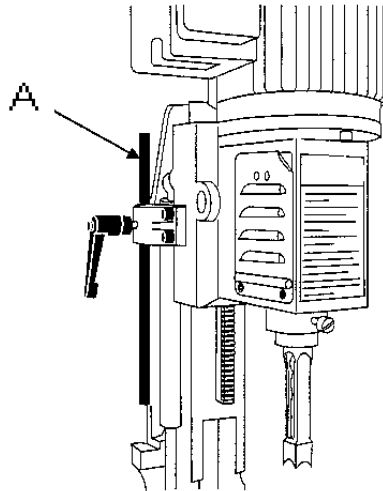

Fig 2

Adjust the work stop (B, Fig1) to suit the workpiece length.

Place the workpiece on the table and clamp the vice (A, Fig3).

The vice has a quick-release function; one full turn to the left will disengage the spindle.

Use the left handwheel to move the table forward and backward to suit the position of the mortise on the workpiece.

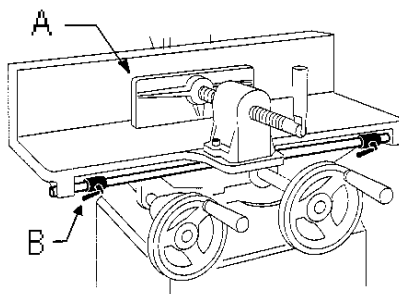

Fig 3

Adjust the table stops (B, Fig3), according to the length of cut required, then tighten the thumb screws.

Turn on the machine and feed chisel and bit steadily into the workpiece by pulling down the operating handle.

NOTE:

The rate of feed must be fast enough to prevent burning at the tip of the drill bit, but not so fast as to cause the machine to stall. The different rates of feed for different woods must be learned by experience.

After the first cut, the workpiece is moved. The direction of movement must allow the chips to clear freely (Fig4).

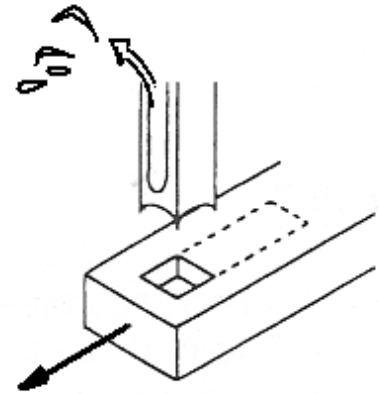

Fig 4

When cutting deep mortises, make the cut in several stages of approx. 25mm each, to allow chips to clear.

To prevent breakout at the back of the workpiece when cutting through mortises, use a piece of scrap material under the workpiece as support.

Warning:

Always keep your hands well clear of the rotating bit.

Always close the chuck cover before you start the machine.

Support long workpieces with helping roller stands.

7. Setup and adjustments

General note:

Setup and adjustment work may only be carried out after the machine is protected against accidental starting by pulling the mains plug.

7.1 Installing chisel and bit

Disconnect the machine from the power source (unplug).

Open the chuck access doors on both sides of the head.

Insert the chisel bushing (3, Fig5) with the hole facing forward into the head.

Insert chisel and bit together.

Tighten the screw (2, Fig5) just enough to hold the chisel (4, Fig5) in place.

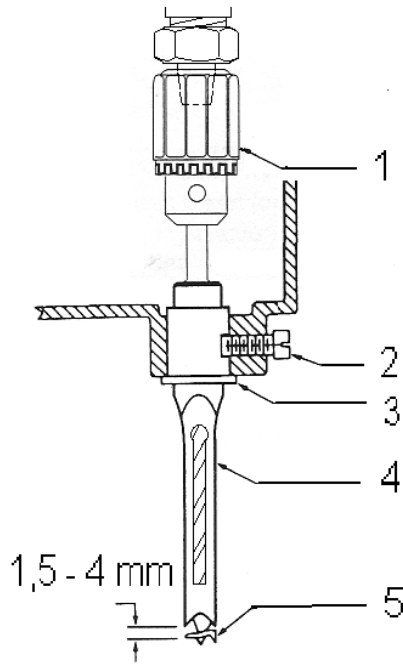

Fig 5

NOTE:

The slot in the chisel should face to the right or left side only. The opening will allow chips to escape during operation.

Push the chisel up as far as possible into the head. Then lower the chisel 1,5 to 4mm, depending on the type of wood being worked. Tighten the screw to hold the chisel in place.

Push the bit up through the chisel opening as far as it will go. Lock the drill bit in place with the chuck key.

Loosen the screw and push the chisel up against the bushing and tighten the screw. This should provide the proper distance between the points of the chisel and the bit.

NOTE: The chisel should be adjusted parallel. Use the workpiece as a gauge (Fig 6).

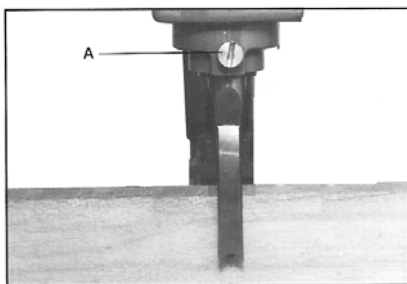

Fig 6

Close the chuck access doors before starting the machine.

Using bits with shorter shanks:

It will be necessary to attach the spindle extension. Place the supplied 32mm open spanner on the chuck release nut and use the chuck key to hold the chuck. Force off the chuck with the chuck release nut. Attach the spindle extension to the chuck and reinstall.

7.2 Sharpening chisel and bit

The chisel and bit should be kept sharp for best performance.

Sharpen the bit by using a small file, following the original shape of the bit.

File the inside edge of the spur (A, Fig7), the sides of the centre point (B, Fig7) and the cutting edge inwards toward the flute of the bit (C, Fig7)

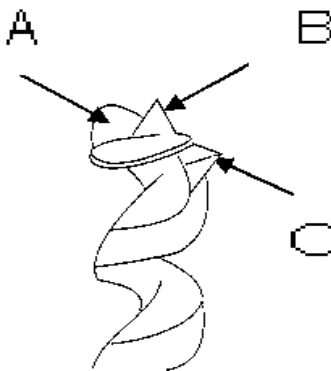

Fig 7

Do not file the outside edges of the spur as this will affect the diameter of the bit.

Sharpen the chisel on the cutting edge inside only.

8. Maintenance and inspection

General notes:

Maintenance, cleaning and repair work may only be carried out after the machine is protected against accidental starting by pulling the mains plug.

The mortise requires only minor maintenance, such as lubrication, routine adjustments and sharpening of chisel and bit.

Clean the machine regularly.

Defective safety devices must be replaced immediately.

Repair and maintenance work on the electrical system may only be carried out by a qualified electrician.

9. Trouble shooting

Motor doesn't start

- *No electricity- check mains and fuse.
- *Defective switch, motor or cord- consult an electrician.

Chisel clogged with chips

- *Clearance chisel to bit not enough- set bit 1,5 to 4mm below chisel.
- *chips cannot clear the chisel- observe chisel slot and working order.

Burned Wood

- *Feed too slow- increase feedrate.
- *Worn chisel or bit- sharpen chisel and bit.

10. Available accessories

Stock number 6285526
6,35 mm chisel and bit

Stock number 6285527
8 mm chisel and bit

Stock number 6285528
9,5 mm chisel and bit

Stock number 6285529
12,7 mm chisel and bit

Stock number 6292447
15,87 mm chisel and bit

Stock number 6292448
19 mm chisel and bit