

# JET

**JPT-260**

**PLANER & THICKNESSER**

JPT-260-M.....10000289M.....1~230V, 50Hz

JPT-260-T.....10000289T.....3~400V, 50Hz

## **PARTS LIST ERSATZTEILLISTE LISTE DE PIECES**

**Walter Meier (Tool) AG**

Tämperlistrasse 5

CH-8117 Fällanden

Switzerland

Phone +41 44 806 47 48

Fax +41 44 806 47 58

[jetinfo.eu@waltermeier.com](mailto:jetinfo.eu@waltermeier.com)

[www.jettools.com](http://www.jettools.com)



P-10000289M/T

2011-04

# JPT-260 Cutter Block Guard and Outfeed Table Assembly

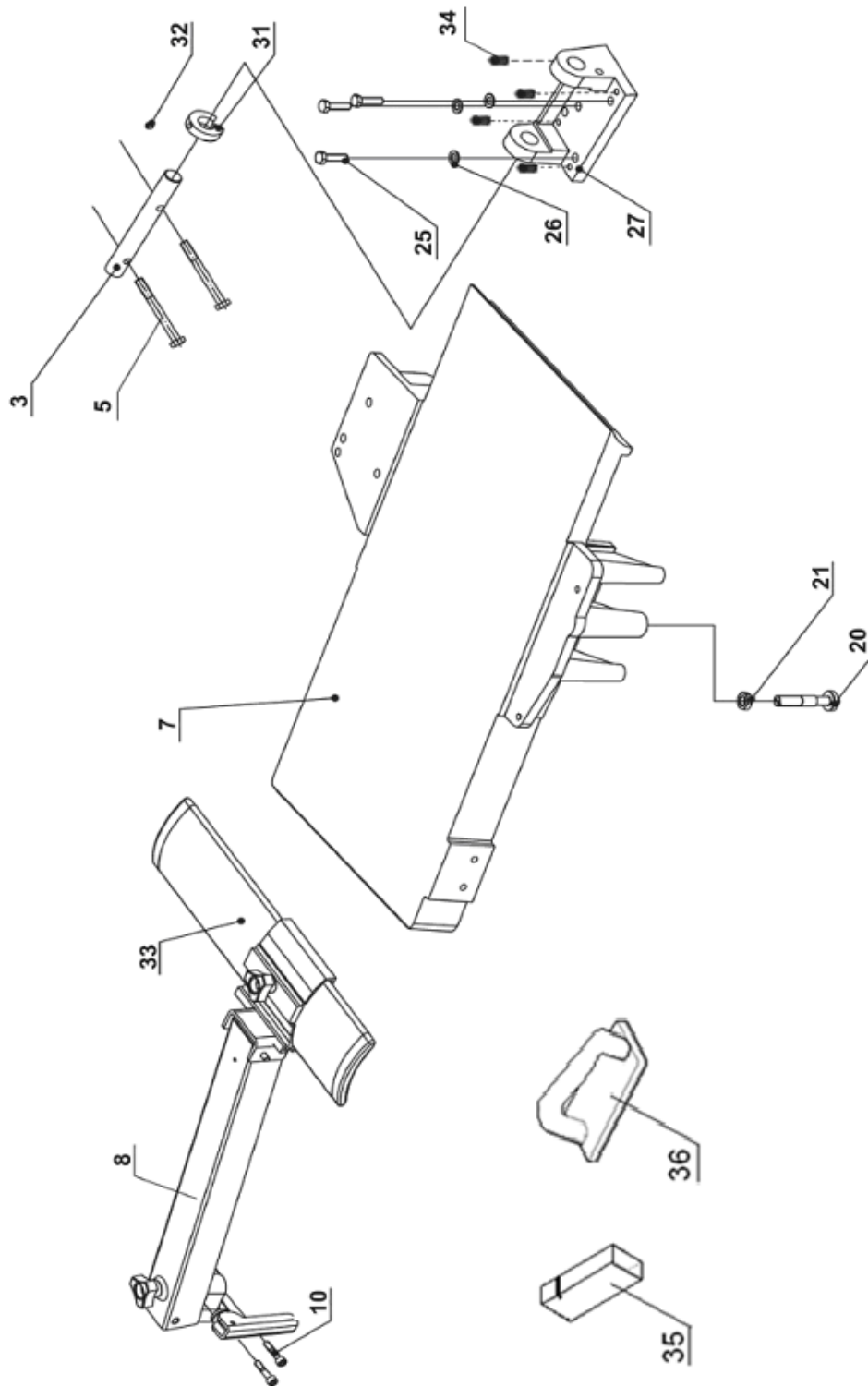

## JPT-260 Cutter Block Guard and Outfeed Table Assembly

Index No.	Part No.	Description	Size	Qty
3.....	JPT310-003 .....	Outfeed table bracket shaft .....		1
5.....	JPT260-005 .....	Hex. Socket cap screw .....	M8X75 .....	2
7.....	JPT260-007 .....	Outfeed table .....		1
8.....	JPT310-008 .....	Cutterblock guard assembly .....		1
10.....	JPT310-010 .....	Hex. Socket cap screw .....	M6X30 .....	2
20.....	JPT310-020 .....	Table locking shaft.....		2
21.....	JPT310-021 .....	Hex. Nut.....	M12.....	2
25.....	JPT310-025 .....	Hex. Bolt .....	M8X30 .....	6
26.....	JPT310-026 .....	Washer .....	M8.....	6
27.....	JPT310-027 .....	Outfeed table support.....		2
31.....	JPT310-031 .....	Big cam wheel for safty switch .....		1
32.....	JPT310-032 .....	Hex. Socket set screw .....	M5X10 .....	1
33.....	JPT260-033 .....	Cutterblock guard profile/plastic end covers.....		1
34.....	JPT310-034 .....	Grub screw .....	M8.....	4
35.....	JPT310-035 .....	Knife gauge .....		1
36.....	JPT310-036 .....	Push block .....		1

# JPT-260 Cutter Block Assembly

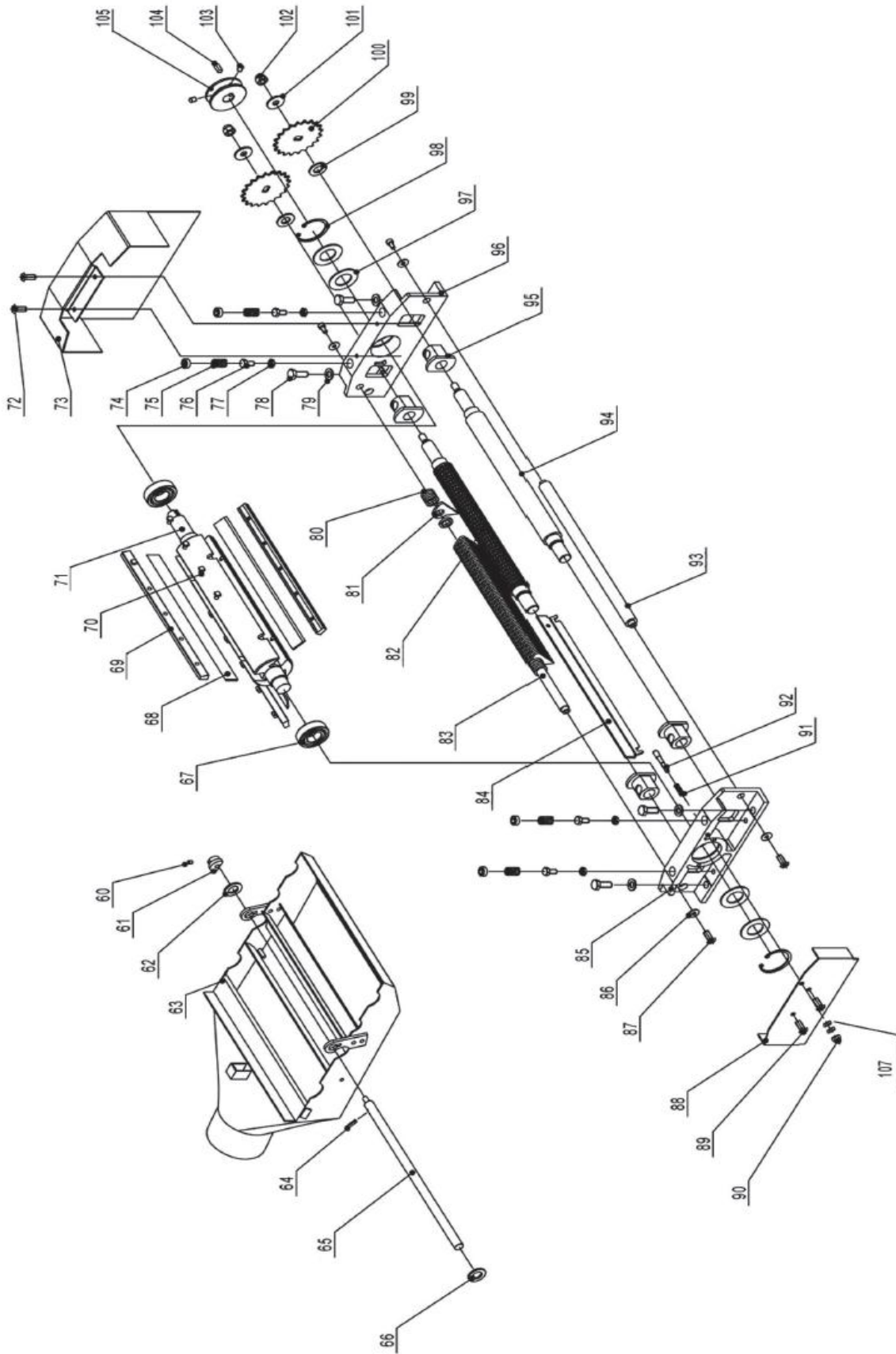

## JPT-260 Cutter Block Assembly

Index No.	Part No.	Description	Size	Qty
60	JPT310-032	Hex. Socket set screw	M5X10	1
61	JPT310-061	Small cam wheel for safty switch		1
62	JPT310-062	Washer	H16	2
63	JPT260-063	Dust collector assembly		1
64	JPT310-064	Pin roll	N5X18	1
65	JPT260-065	Shaft		1
66	JPT310-066	Washer	H16	2
67	JPT310-067	Bearing BRG6205-ZZCM		2
68	JPT260-068	Knife		3
69	JPT260-069	Knife locking bar		3
70	JPT310-070	Special screw for locking bar		15
71	JPT260-071	Cutter block		1
72	JPT310-072	Pan head screw	M6X12	4
73	JPT310-073	Belt cover		1
74	JPT310-074	Screw		4
75	JPT310-075	Spring		4
76	JPT310-076	Hex. bolt	M8X16	4
77	JPT310-077	Hex. nut	M8	4
78	JPT310-078	Hex. bolt	M10X25	4
79	JPT310-079	Washer	H10	4
80	JPT310-080	Adjusting washer		48
81	JPT310-081	Anti-kickback finger		38
82	JPT260-082	Infeed roller		1
83	JPT260-083	Anti-kickback shaft		1
84	JPT260-084	Cutterblock cover		1
85	JPT310-085	Cutterblock bracket-right		1
86	JPT310-086	Washer	M6	4
87	JPT310-087	Hex. Socket cap screw	M6X12	4
88	JPT310-088	Cutterblock bracket cover		1
89	JPT310-089	Pan head screw	M6X12	2
90	JPT310-090	Cap nut	M6	1
91	JPT310-091	Spring		1
92	JPT310-092	Pin stop for Dust collector		1
93	JPT260-093	Support rod		1
94	JPT260-094	Outfeed rubber roller		1
95	JPT310-095	Tube (powder steel bushing)		4
96	JPT310-096	Cutterblock bracket-left		1
97	JPT310-097	Wave washer	D52	2
98	JPT310-098	Retaining ring	CLP52	2
99	JPT310-099	Washer		2
100	JPT310-100	Drive chain sprocket		1
101	JPT310-101	Washer	WSH10	2
102	JPT310-102	Lock nut	M10	2
103	JPT260-103	Hex. Socket set screw	M8X6	2
104	JPT310-104	Key	PLN6X16	1
105	JPT260-105	Spindle pulley		1
106	JPT260-106	Washer	D52	2
107	JPT260-107	Nut	M6	2
	JPT310-110	Knife adjust screw (not shown)	M6x20 DIN 7991	6

# JPT-260 Base Assembly

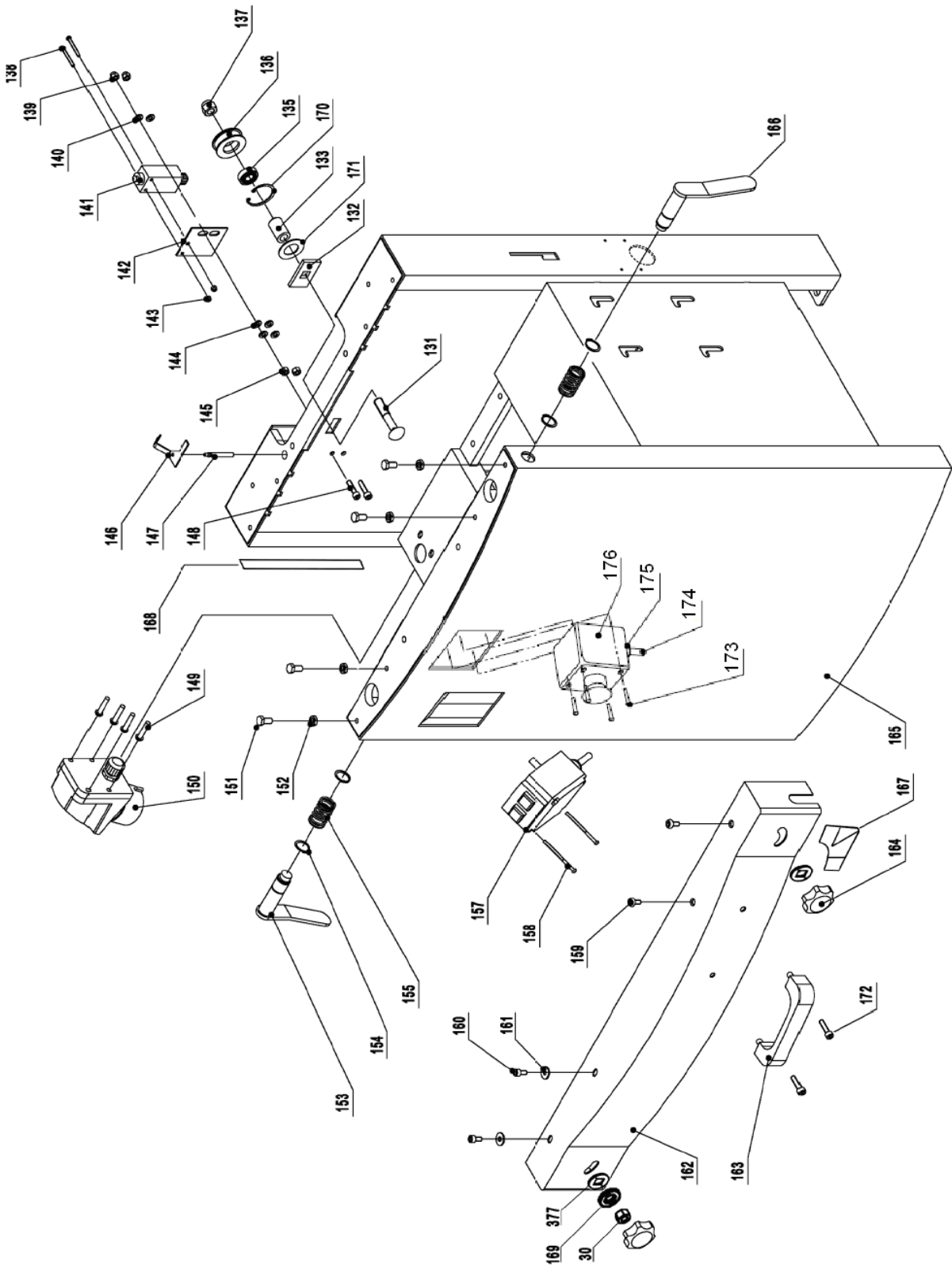

## JPT-260 Base Assembly

Index No.	Part No.	Description	Size	Qty
131	JPT310-131	Carriage bolt	N12X65	1
132	JPT310-132	Square washer		1
133	JPT310-133	Tube		1
135	JPT310-135	Bearing	BRG80101	1
136	JPT310-136	Chain tension wheel		1
	JPT310-136A	Chain tension wheel Assembly (131-137, 170, 171)		1
137	JPT310-137	Lock nut	M12	1
138	JPT310-138	Pan head screw	M4X35	2
139	JPT310-139	Lock nut	M6	2
140	JPT310-140	Washer	H6	10
141	JPT310-141	Safety switch		1
142	JPT310-142	Safety switch bracket		1
143	JPT310-143	Lock nut	M4	2
144	JPT310-144	Washer	H6	4
145	JPT310-145	Hex. Nut	M6	2
146	JPT310-146	Safety switch rocker		1
147	JPT310-147	Safety switch rocker shaft		1
148	JPT310-148	Hex. Socket cap screw	M6X25	2
149	JPT310-149	Pan head screw	M4X16	4
150	JPT310-150E	Plug 230/50/1		1
	JPT310-150AE	Plug 400/50/1		1
151	JPT310-151	Special bolt		4
152	JPT310-152	Hex. Nut	M8	4
153	JPT310-153	Lock handle for outfeed table		1
154	JPT310-154	Retaining ring	CLP20	4
155	JPT310-155	Spring		2
156	JPT310-156	Direction label		1
157	JPT310-157E	Switch 230/50(60)/1		1
	JPT310-157AE	Switch 400/50/1		1
158	JPT310-158	Pan head screw	N4X60	2
159	JPT310-159	Pan head screw	M6X16	2
160	JPT310-160	Pan head screw	M6X12	2
161	JPT310-161	Washer	H6	7
162	JPT260-162	Front cover		1
163	JPT310-163	Handle		1
164	JPT310-164	Lock knob		4
165	JPT260-165	Cabinet		1
166	JPT310-166	Lock handle for infeed table		1
167	JPT310-167	Infeed scale		1
168	JPT310-168	Thickness scale		1
169	JPT310-169	Washer	H8	2
170	JPT310-170	Retaining ring		1
171	JPT310-171	Washer	H12	1
172	JPT310-172	Hex socket head screw	M8X20	2
173	JPT310-173	Screw	M4X10	4
174	JPT310-174	Cable for safety switch		1
175	JPT310-175	Strain relief		1
176	JPT310-176	E-Stop Button		1

# JPT-260 Infeed Table Assembly

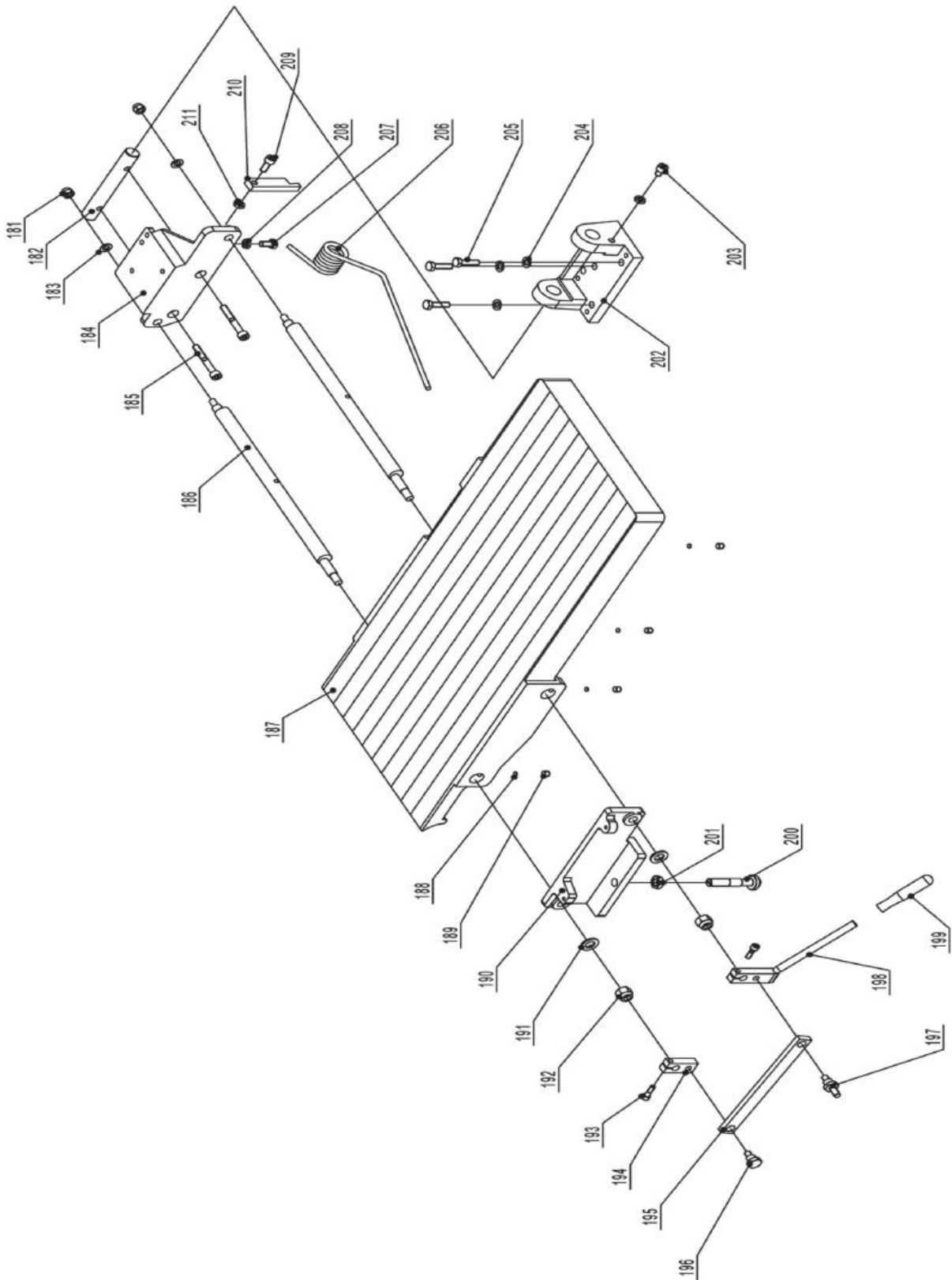



## JPT-260 Infeed Table Assembly

Index No.	Part No.	Description	Size	Qty
181	JPT310-181	Lock nut	M8	2
182	JPT310-182	Outfeed table bracket shaft		1
183	JPT310-183	Washer		2
184	JPT310-184	Infeed table bracket right		1
185	JPT310-185	Hex. Socket cap screw	M8X75	2
186	JPT260-186	Eccentric shaft		2
187	JPT260-187	Infeed table		1
188	JPT310-188	Plastic disc	D6	4
189	JPT310-189	Hex socket set screw	M8X10	4
190	JPT310-190	Infeed table bracket left		1
191	JPT310-191	Washer	H12	2
192	JPT310-192	Lock nut	M12	2
193	JPT310-193	Hex. Socket cap screw	M6X20	4
194	JPT310-194	Eccentric shaft clamp		1
195	JPT310-195	Eccentric shaft bracket		1
196	JPT310-196	Special screw		1
197	JPT310-197	Special screw		1
198	JPT310-198	Adjusting handle		2
199	JPT310-199	Knob		1
200	JPT310-200	Table locking shaft		1
201	JPT310-201	Hex. Nut	M12	1
202	JPT310-202	Infeed table support		2
203	JPT310-203	Hex. Socket cap screw	M8X16	1
204	JPT310-204	Washer	H8	3
205	JPT310-205	Hex. bolt	M8X30	3
206	JPT310-206	Spring		1
207	JPT310-207	Hex. bolt	M8X16	1
208	JPT310-208	Hex. nut	M8	1
209	JPT310-209	Hex. Socket cap screw	M8X40	1
210	JPT310-210	Table stopper		1
211	JPT310-211	Hex. Nut	M8	1

JPT-260 Drive and Motor Assembly

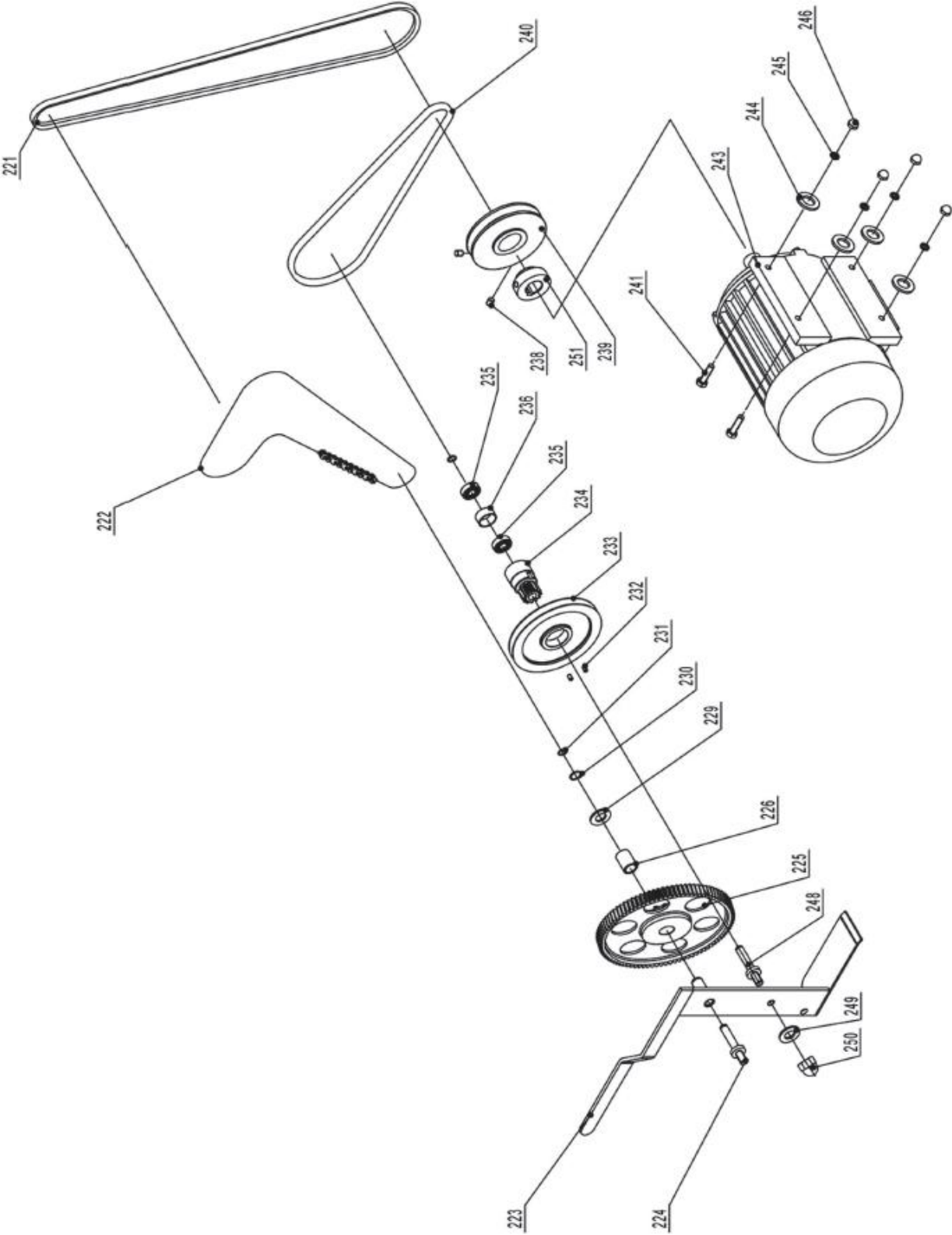

## JPT-260 Drive and Motor Assembly

Index No.	Part No.	Description	Size	Qty
221	JPT260-221	V-belt for cutterblock 50Hz	Z1200	1
	JPT260-221SAE	V-belt for cutterblock 60Hz		1
222	JPT310-222	Drive chain		1
223	JPT310-223	Cam wheel bracket		1
224	JPT310-224	Cam wheel shaft		1
225	JPT310-225A	Plastic gear wheel assembly		1
226	JPT310-226	Tube		1
229	JPT310-229	Washer		1
230	JPT310-230	Retaining ring	CLP15	1
231	JPT310-231	Retaining ring	CLP10	2
232	JPT310-232	Hex. Socket set screw	M5X10	2
233	JPT260-233	V-belt pulley for feed roller		1
234	JPT310-234	Cam wheel		1
235	JPT310-235	Bearing	BRG80100	2
236	JPT310-236	Spacer bearing		1
238	JPT260-238	Hex. Socket set screw	M8X12	2
239	JPT260-239	Big motor pulley 50Hz		1
	JPT260-239SAE	Big motor pulley 60Hz		1
240	JPT260-240	Flat belt for feed roller		1
241	JPT310-241	Hex. Bolt	M8X25	4
243	JPT260-243E	Motor 230/50/1		1
	JPT260-243SAE	Motor 230/60/1		1
	JPT260-243AE	Motor 400/50/1		1
244	JPT310-244	Washer	H8	4
245	JPT310-245	Spring washer	H8	4
246	JPT310-246	Cap hex. Nut	M8	4
247	JPT260-247	Capacitor 230/50/1 (not shown)		1
247	JPT260-247	Capacitor 230/60/1 (not shown)		1
248	JPT310-248	Shaft		1
249	JPT310-249	Spring washer	H10	1
250	JPT310-250	Hex nut	M10	1
251	JPT260-251	Small motor pulley 50Hz		1
	JPT260-251	Small motor pulley 60Hz		1

# JPT-260 Thickness Table Assembly

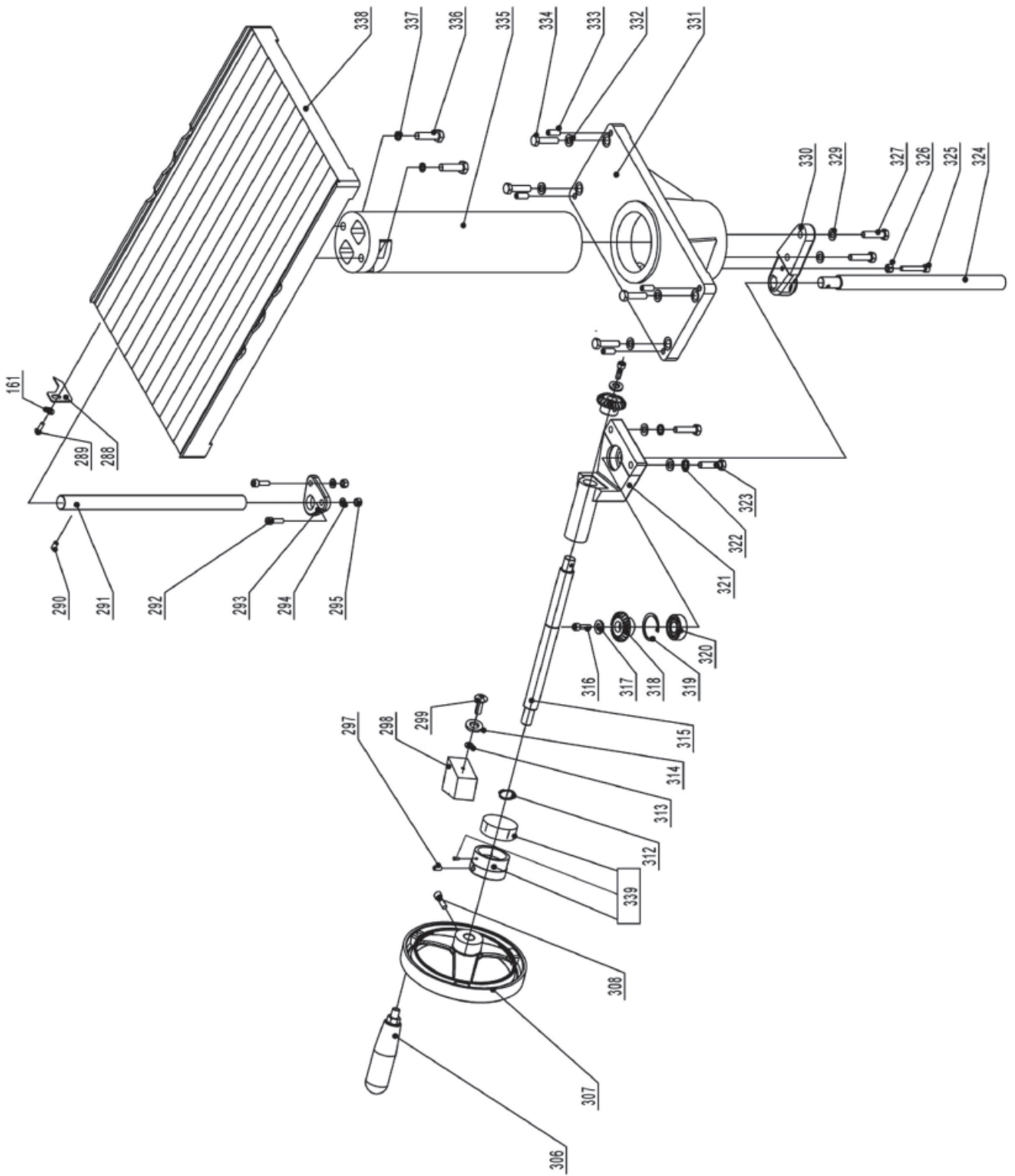

## JPT-260 Thickness Table Assembly

Index No.	Part No.	Description	Size	Qty
288	JPT310-288	Indicator		1
289	JPT310-289	Screw	M6X12	1
290	JPT310-290	Hex. Socket set screw	M8X12	1
291	JPT310-291	Thickness table guide bar		1
292	JPT310-292	Hex. Socket cap screw	M6X20	2
293	JPT310-293	Guide bar bracket		1
294	JPT310-294	Washer	H6	2
295	JPT310-295	Hex. Nut	M6	2
297	JPT310-297	Hex socket set screw	M8X12	1
298	JPT310-298	Indicator seat		1
299	JPT310-299	Screw	M6X20	2
306	JPT310-306	Crank handle		1
307	JPT260-307	Crank handwheel		1
308	JPT310-308	Hex. Socket cap screw	M6X20	1
312	JPT310-312	Retaining ring	CLP20	1
313	JPT310-313	Retaining ring	CLP35	1
314	JPT310-314	Washer		1
315	JPT310-315	Crank bar		1
316	JPT310-316	Pan head screw	M6X12	2
317	JPT310-317	Washer	M6	2
318	JPT310-318	Bevel gear		1
319	JPT310-319	Retaining ring	CLP35	1
320	JPT310-320	Bearing	BRG80202	1
321	JPT310-321	Bevel gear bracket		1
322	JPT310-322	Washer	H8	8
323	JPT310-323	Hex. bolt	M8X35	8
324	JPT310-324	Thread rod		1
325	JPT310-325	Hex. bolt	M6X40	1
326	JPT310-326	Hex. nut	M6	1
327	JPT310-327	Hex. bolt	M8X35	2
329	JPT310-329	Washer	H8	2
330	JPT310-330	Thread rod bracket		1
331	JPT260-331	Column support		1
332	JPT310-332	Washer		4
333	JPT310-333	Hex. Socket set screw	M8X20	5
334	JPT310-334	Screw		4
335	JPT310-335	Column		1
336	JPT310-336	Hex. bolt	M10X35	2
337	JPT310-337	Spring washer	H10	2
338	JPT260-338	Thickness table		1
339	JPT310-339	Scale ring assembly		1

# JPT-260 Working Fence Assembly

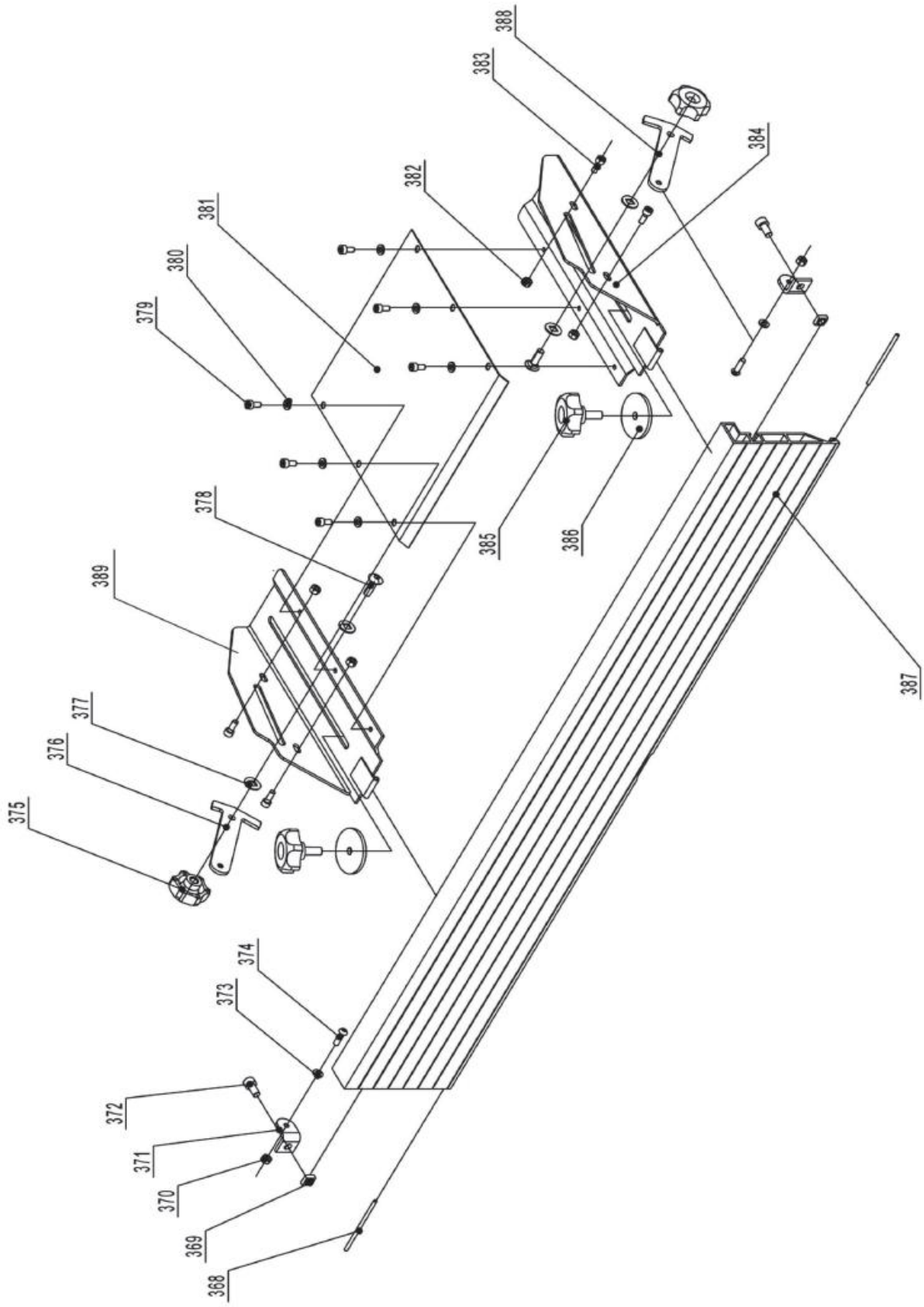

## JPT-260 Working Fence Assembly

Index No.	Part No.	Description	Size	Qty
368	JPT310-368	Pin for hinge		1
369	JPT310-369	Square nut	M8	2
370	JPT310-370	Lock nut	M6	6
371	JPT310-371	Fence mounting bracket		2
372	JPT310-372	Hex. bolt	M8X16	2
373	JPT310-373	Washer		2
374	JPT310-374	Hex. Socket cap screw	M6X16	2
375	JPT310-375	Lock knob		2
376	JPT310-376	Fence support-right		1
377	JPT310-377	Nylon washer		10
378	JPT310-378	Carriage bolt	M8X25	2
379	JPT310-379	Pan head screw	M6X12	6
380	JPT310-380	Washer	H6	6
381	JPT310-381	Cutterblock cover		1
382	JPT310-382	Lock nut	M6	4
383	JPT310-383	Hex. Socket cap screw	M6X12	4
384	JPT310-384	Fence bracket-left		1
385	JPT260-385	Lock handle		2
386	JPT310-386	Special washer		2
387	JPT260-387	Fence		1
388	JPT310-388	Fence support-left		1
389	JPT310-389	Fence bracket-right		1
390	JPT260-390	Fence scale		1
391	JPT260-391	Complete fence assembly (368-390)		1

# JPT-260-M

## 10000289M

	colour of strands	Litzenfarben	couleur des cordons
BK	black	schwarz	noir
WH	white	weiß	blanc
BU	blue	blau	bleu
YE	yellow	gelb	jaune
RD	red	rot	rouge
BN	brown	braun	brun
GY	grey	grau	gris
GNYE	green-yellow	grün-gelb	vert-jaune
OG	orange	orange	orange
VT	violet	violett	violet

	meaning of symbol	Bedeutung der Zeichen	interprétation
M	motor	Motor	moteur
S	switch	Schalter	interrupteur
C	condenser	Kondensator	condensateur
F	fuse	Sicherung	fusible
RS	reversing switch	Drehrichtungsschalter	commu. droite/gauche
CS	centrifugal switch	Fliehkraftschalter	déclencheur centrifuge
OL	overload cut-off	Überlastschuttschalter	déclencheur surcharge
LS1	limit switch	Positionsendschalter	micro
LS2	E-stop	Not-Aus Taster	arret d'urgence

1~230V, 50Hz

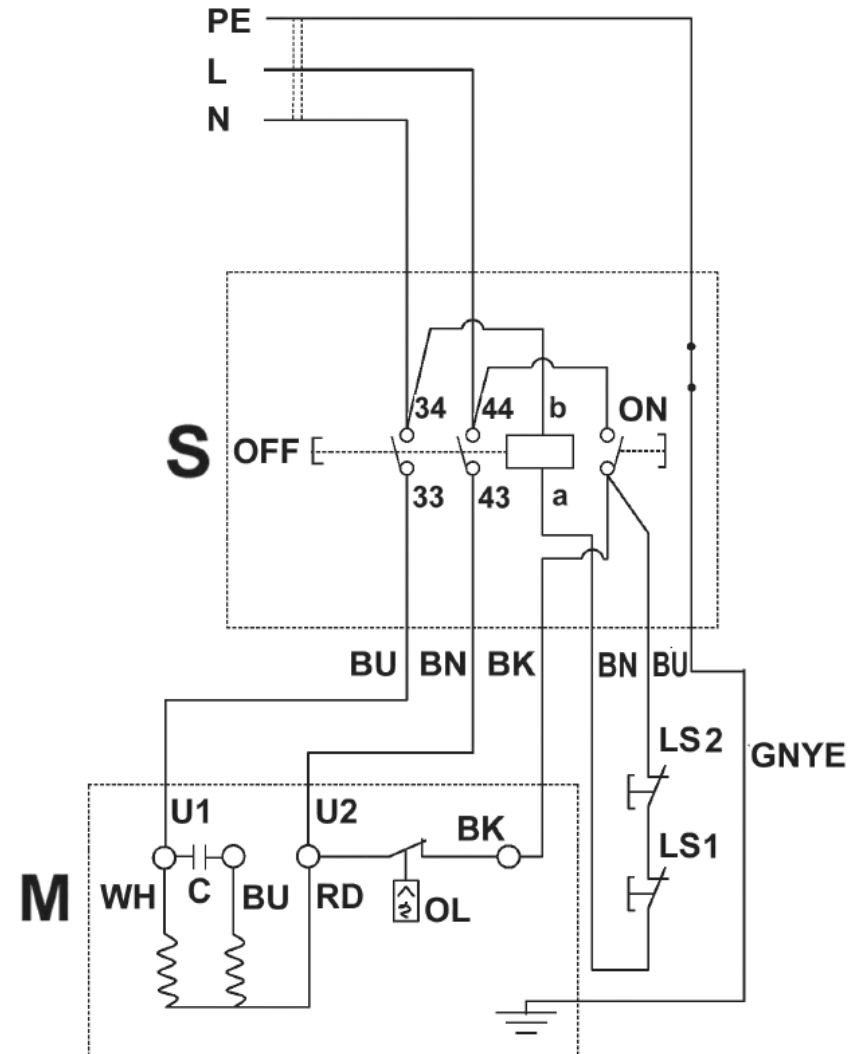



# JPT-260-T

10000289T

	colour of strands	Litzenfarben	couleur des cordons
BK	black	schwarz	noir
WH	white	weiß	blanc
BU	blue	blau	bleu
YE	yellow	gelb	jaune
RD	red	rot	rouge
BN	brown	braun	brun
GY	grey	grau	gris
GNYE	green-yellow	grün-gelb	vert-jaune
OG	orange	orange	orange
VT	violet	violett	violet

	meaning of symbol	Bedeutung der Zeichen	interprétation
M	motor	Motor	moteur
S	switch	Schalter	interrupteur
C	condenser	Kondensator	condensateur
F	fuse	Sicherung	fusible
RS	reversing switch	Drehrichtungsschalter	commu. droite/gauche
CS	centrifugal switch	Fliehkraftschalter	déclencheur centrifuge
OL	overload cut-off	Überlastschuttschalter	déclencheur surcharge
LS1	Limit switch	Positionsendschalter	micro
LS2	E-stop	Not-Aus Taster	arret d'urgence

3~400V, 50Hz

