

JET

JPT-310

PLANER & THICKNESSER

JPT-310-M.....10000290M....1~230V, 50Hz

JPT-310-T.....10000290T.....3~400V, 50Hz

PARTS LIST ERSATZTEILLISTE LISTE DE PIECES

Walter Meier (Tool) AG

Tämperlistrasse 5

CH-8117 Fällanden

Switzerland

Phone +41 44 806 47 48

Fax +41 44 806 47 58

jetinfo.eu@waltermeier.com

www.jettools.com



P-10000290M/T

2011-04

JPT-310 Cutter Block Guard and Outfeed Assembly

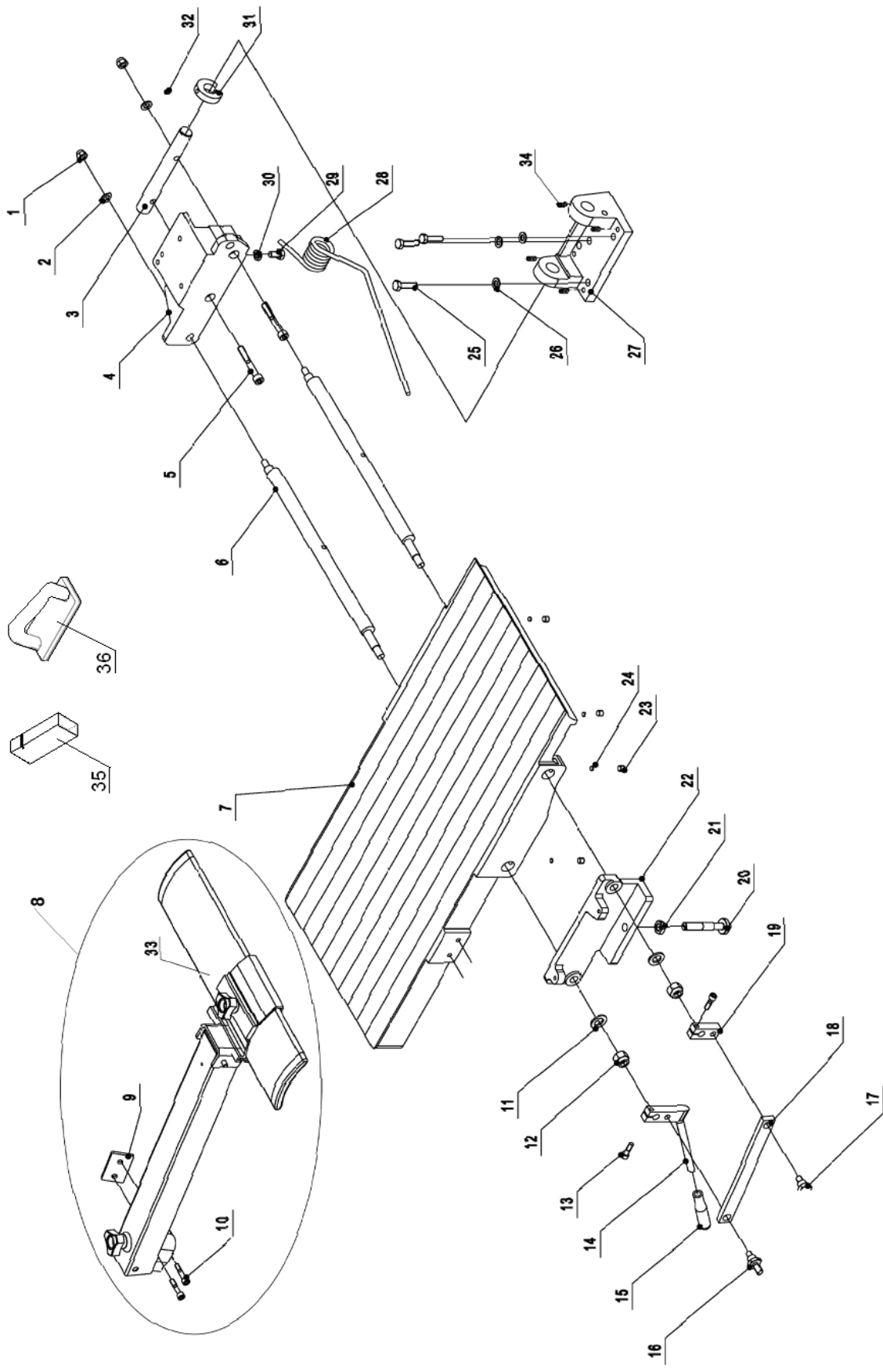

JPT-310 Cutter Block Guard and Outfeed Assembly

Index No.	Part No.	Description	Size	Qty
1	JPT310-001	Lock nut	M8	4
2	JPT310-002	Washer		4
3	JPT310-003	Outfeed table bracket shaft		1
4	JPT310-004	Outfeed table bracket right		1
5	JPT310-005	Hex. Socket cap screw	M8X60	4
6	JPT310-006	Eccentric shaft		4
7	JPT310-007	Outfeed/Infeed Table		2
8	JPT310-008	Cutterblock guard assembly		1
9	JPT310-009	Cutterblock guard bracket		1
10	JPT310-243	Hex. Socket cap screw	M6X30	2
11	JPT310-011	Washer	H12	4
12	JPT310-012	Lock nut	M12	4
13	JPT310-013	Hex. Socket cap screw	M6X20	4
14	JPT310-014	Adjusting handle		2
15	JPT310-015	Knob		2
16	JPT310-016	Special screw		2
17	JPT310-017	Special screw		2
18	JPT310-018	Eccentric shaft bracket		2
19	JPT310-019	Eccentric shaft clamp		2
20	JPT310-020	Table locking shaft		2
21	JPT310-021	Hex. Nut	M12	2
22	JPT310-022	Outfeed table bracket left		1
23	JPT310-023	Hex. Socket set screw	M8X10	8
24	JPT310-024	Plastic disc	D6	8
25	JPT310-025	Hex. Bolt	M8X30	6
26	JPT310-026	Washer	H8	6
27	JPT310-027	Outfeed table support		2
28	JPT310-028	Spring		2
29	JPT310-029	Hex. bolt	M8X16	2
30	JPT310-030	Hex. nut	M8	3
31	JPT310-031	Big cam wheel for safty switch		1
32	JPT310-032	Hex. Socket set screw	M5X10	1
33	JPT310-033	Cutterblock guard profile w/cap		1
34	JPT310-034	Grub screw	M8	8
35	JPT310-035	Knife gauge		1
36	JPT310-036	Push block		1

JPT-310 Cutter Block assembly

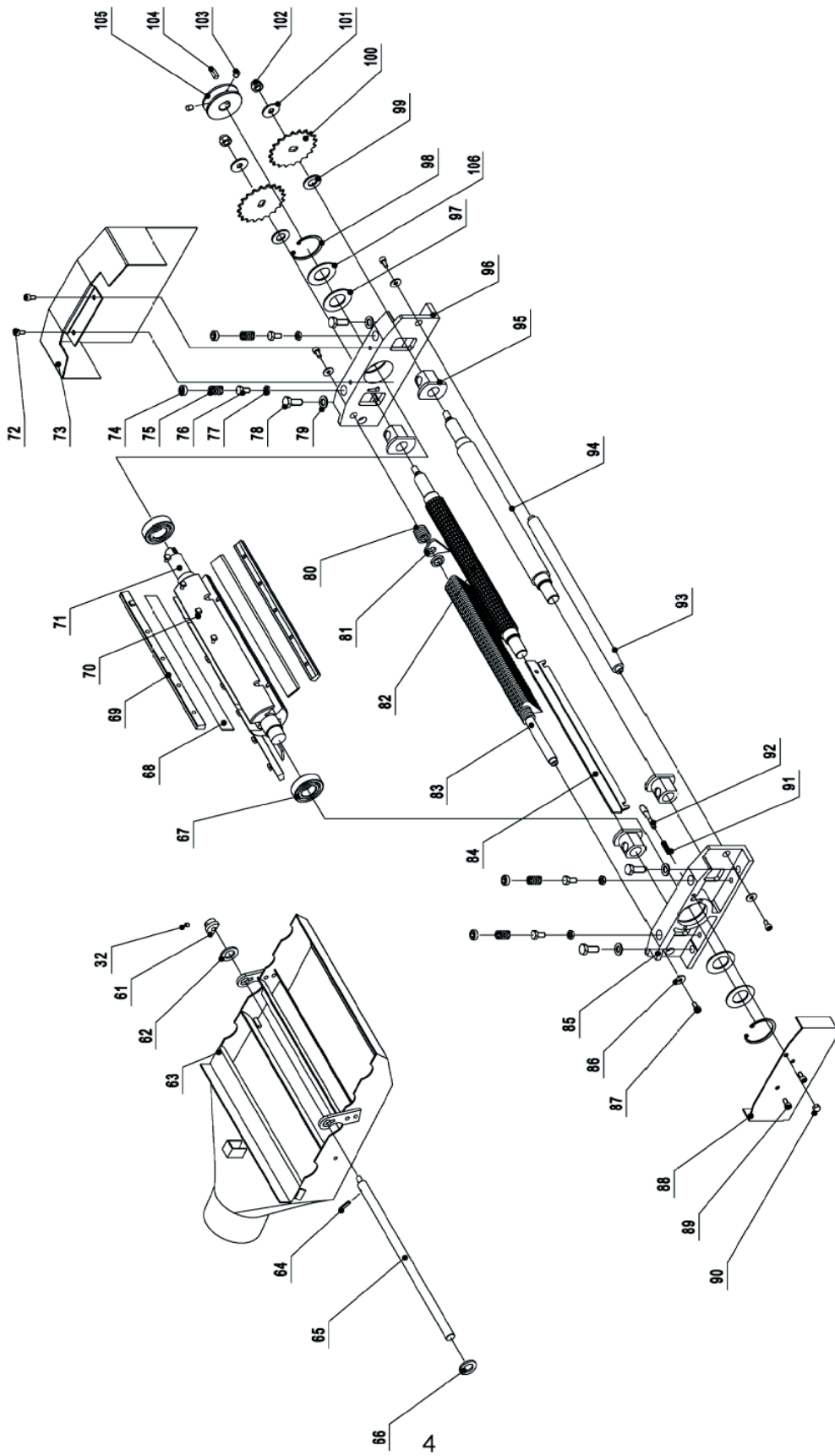

JPT-310 Cutter Block assembly

Index No.	Part No.	Description	Size	Qty
61	JPT310-061	Small cam wheel for safty switch		1
62	JPT310-062	Washer	H16	2
63	JPT310-063	Dust collector assembly		1
64	JPT310-064	Pin roll	N5X18	1
65	JPT310-065	Shaft		1
66	JPT310-066	Washer	H16	2
67	JPT310-067	Bearing BRG6205-ZZCM		2
68	JPT310-068	Knife		3
69	JPT310-069	Knife locking bar		3
70	JPT310-070	Special screw for locking bar		15
71	JPT310-071	Cutter block		1
	JPT310-071CBA	Cutter block complete assembly (68, 69, 70, 71)		
72	JPT310-072	Pan head screw	M6X12	4
73	JPT310-073	Belt cover		1
74	JPT310-074	Screw		4
75	JPT310-075	Spring		4
76	JPT310-076	Hex. bolt	M8X16	4
77	JPT310-077	Hex. nut	M8	4
78	JPT310-078	Hex. bolt	M10X25	4
79	JPT310-079	Washer	H10	4
80	JPT310-080	Adjusting washer		48
81	JPT310-081	Anti-kickback finger		38
82	JPT310-082	Infeed roller		1
83	JPT310-083	Anti-kickback shaft		1
84	JPT310-084	Cutterblock cover		1
85	JPT310-085	Cutterblock bracket-right		1
86	JPT310-086	Washer	M6	4
87	JPT310-087	Hex. Socket cap screw	M6X12	4
88	JPT310-088	Cutterblock bracket cover		1
89	JPT310-089	Pan head screw	M6X12	2
90	JPT310-090	Cap nut	M6	1
91	JPT310-091	Spring		1
92	JPT310-092	Pin stop for Dust collector		1
93	JPT310-093	Support rod		1
94	JPT310-094	Outfeed roller		1
95	JPT310-095	Tube (Powder Metal Bushing)		4
96	JPT310-096	Cutterblock bracket-left		1
97	JPT310-097	Wave washer	D52	2
98	JPT310-098	Retaining ring	CLP52	2
99	JPT310-099	Washer		2
100	JPT310-100	Drive chain sprocket		2
101	JPT310-101	Washer	WSH10	2
102	JPT310-102	Lock nut	M10	2
103	JPT310-103	Hex. Socket set screw	M8X6	2
104	JPT310-104	Key	PLN6X16	1
105	JPT310-105	Spindle pulley		1
106	JPT310-106	Washer	D52	2
	JPT310-110	Knife adjust screw (not shown)	M6x20 DIN 7991	6

JPT-310 Base Assembly

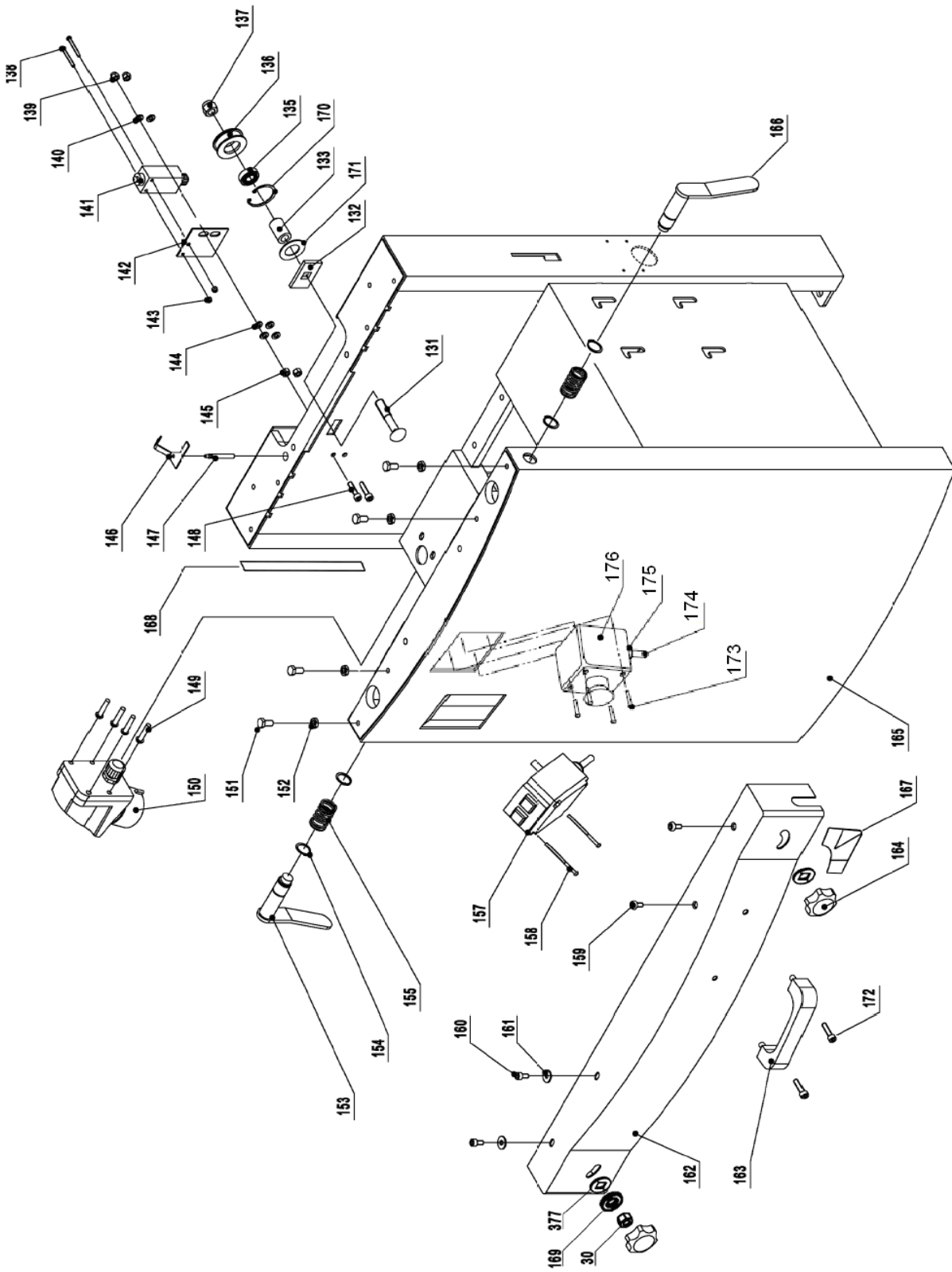

JPT-310 Base Assembly

Index No.	Part No.	Description	Size	Qty
131	JPT310-131	Carriage bolt	M12X65	1
132	JPT310-132	Square washer		1
133	JPT310-133	Tube		1
135	JPT310-135	Bearing	BRG80101	1
136	JPT310-136	Chain wheel		1
	JPT310-136A	Chain tension wheel assembly (131-137, 170, 171)		1
137	JPT310-137	Lock nut	M12	1
138	JPT310-138	Pan head screw	M4X35	2
139	JPT310-139	Lock nut	M6	2
140	JPT310-140	Washer	H6	10
141	JPT310-141	Safety switch		1
142	JPT310-142	Safety switch bracket		1
143	JPT310-143	Lock nut	M4	2
144	JPT310-144	Washer	H6	4
145	JPT310-145	Hex. Nut	M6	2
146	JPT310-146	Safety switch rocker		1
147	JPT310-147	Safety switch rocker shaft		1
148	JPT310-148	Hex. Socket cap screw	M6X25	2
149	JPT310-149	Pan head screw	M4X16	4
150	JPT310-150E	Plug 230/50/1		1
	JPT310-150AE	Plug 400/50/1		1
151	JPT310-151	Special bolt		4
152	JPT310-152	Hex. Nut	M8	4
153	JPT310-153	Lock handle for outfeed table		1
154	JPT310-154	Retaining ring	CLP20	4
155	JPT310-155	Spring		2
156	JPT310-156	Direction label		1
157	JPT310-157E	Switch 230/50(60)/1		1
	JPT310-157AE	Switch 400/50/1		1
158	JPT310-158	Pan head screw	N4X60	2
159	JPT310-159	Pan head screw	M6X16	2
160	JPT310-160	Pan head screw	M6X12	2
161	JPT310-161	Washer	H6	7
162	JPT310-162	Front cover		1
163	JPT310-163	Handle		1
164	JPT310-164	Lock knob		4
165	JPT310-165	Cabinet		1
	JPT310-165CC	Cabinet Cover (not shown)		1
166	JPT310-166	Lock handle for infeed table		1
167	JPT310-167	Infeed scale		1
168	JPT310-168	Thickness scale		1
169	JPT310-169	Washer	H8	2
170	JPT310-170	Retaining ring		1
171	JPT310-171	Washer	H12	1
172	JPT310-172	Hex socket head screw	M8X20	2
173	JPT310-173	Screw	M4X10	4
174	JPT310-174	Cable for safety switch		1
175	JPT310-175	Strain relief		1
176	JPT310-176	E-Stop Button		1

JPT-310 Infeed Table Assembly

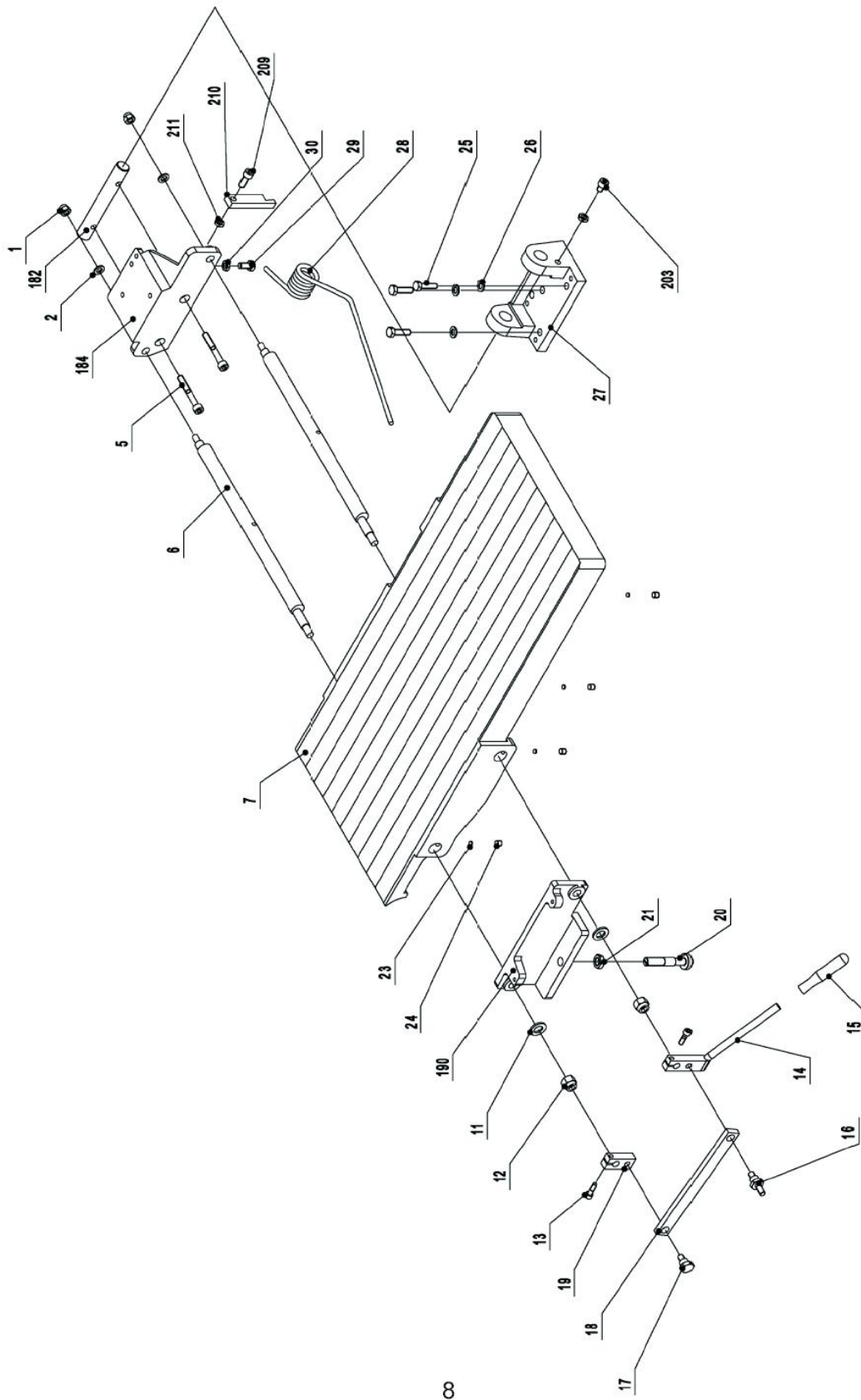

JPT-310 Infeed Table Assembly

Index No.	Part No.	Description	Size	Qty
184	JPT310-184	Infeed table bracket right	M8X60	2
190	JPT310-190	Infeed table bracket left		1
203	JPT310-203	Hex. Socket cap screw	M8X16	1
209	JPT310-209	Hex. Socket cap screw	M8X40	1
210	JPT310-210	Table stopper		1
211	JPT310-211	Hex. Nut	M8	3

JPT-310 Drive and Motor Assembly

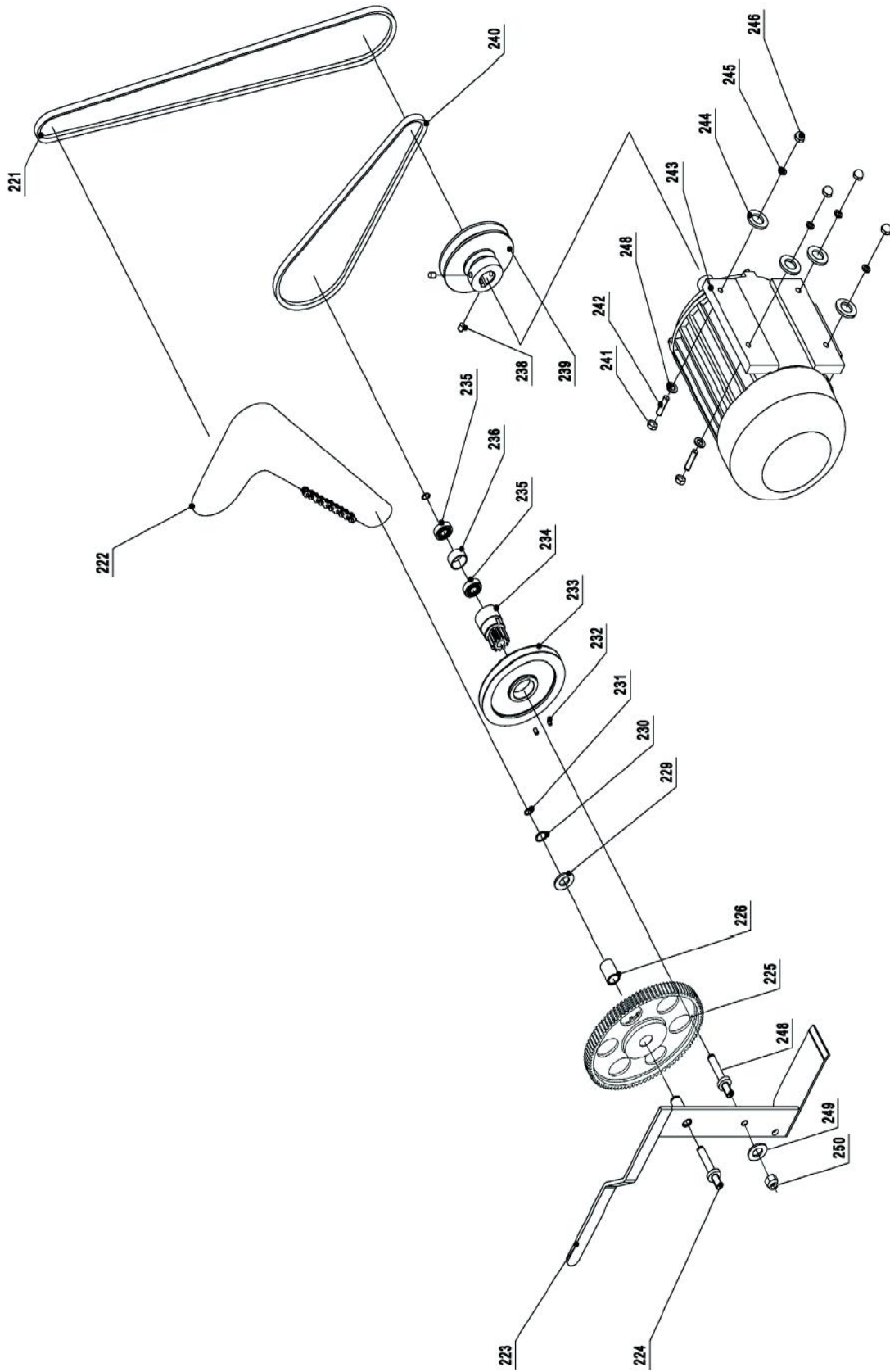

JPT-310 Drive and Motor Assembly

Index No.	Part No.	Description	Size	Qty
221	JPT310-221	V-belt for cutterblock 50Hz	A1194	1
	JPT310-221SAE	V-belt for cutterblock 60Hz		1
222	JPT310-222	Drive chain		1
223	JPT310-223	Cam wheel bracket		1
224	JPT310-224	Cam wheel shaft		1
225	JPT310-225A	Plastic Gear wheel assembly		1
226	JPT310-226	Tube (Bushing)		1
229	JPT310-229	Washer		1
230	JPT310-230	Retaining ring	CLP15	1
231	JPT310-231	Retaining ring	CLP10	2
232	JPT310-232	Hex. Socket set screw	M5X10	2
233	JPT310-233	V-belt pulley for feed roller		1
234	JPT310-234	Cam wheel		1
235	JPT310-235	Bearing	BRG80100	2
236	JPT310-236	Spacer bearing		1
238	JPT310-238	Hex. Socket set screw	M8X12	2
239	JPT310-239	Motor pulley 50Hz		1
	JPT310-239SAE	Motor pulley 60Hz		1
240	JPT310-240	V-belt for feed roller	A770	1
241	JPT310-241	Hex. Bolt	M8X25	4
242	JPT310-242	Washer	H8	4
243	JPT310-010E	Motor 230/50/1		1
	JPT310-010SAE	Motor 230/60/1		1
	JPT310-010AE	Motor 400/50/3		1
244	JPT310-244	Washer	H8	4
245	JPT310-245	Spring washer	H8	4
246	JPT310-246	Cap hex. Nut	M8	4
247	JPT310-247	Capacitor 230/50/1 (not shown)	60 μ F/450VAC	1
247	JPT310-247	Capacitor 230/60/1 (not shown)		1
248	JPT310-248	Shaft		1
249	JPT310-249	Spring washer	H10	1
250	JPT310-250	Hex nut	M10	1

JPT-310 Thickness Table Assembly

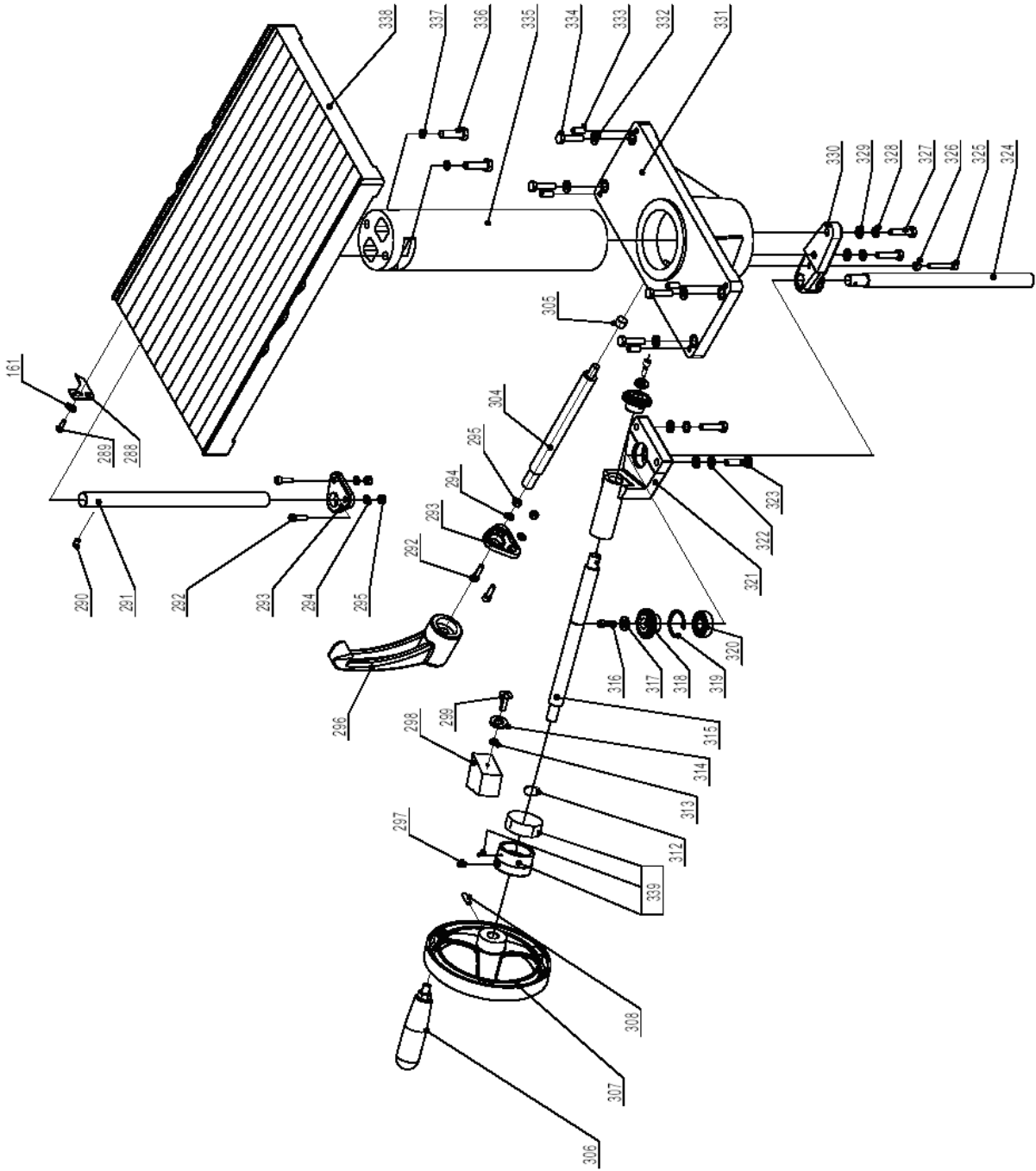

JPT-310 Thickness Table Assembly

Index No.	Part No.	Description	Size	Qty
288	JPT310-288	Indicator		1
289	JPT310-289	Screw	M6X12	1
290	JPT310-290	Hex. Socket set screw	M8X12	1
291	JPT310-291	Thickness table guide bar		1
292	JPT310-292	Hex. Socket cap screw	M6X20	2
293	JPT310-293	Guide bar bracket		2
294	JPT310-294	Washer	H6	2
295	JPT310-295	Hex. Nut	M6	2
296	JPT310-296	Lock handle		1
297	JPT310-297	Hex socket set screw	M8X12	1
298	JPT310-298	Indicator seat		1
299	JPT310-299	Screw	M6X20	2
304	JPT310-304	Locking bar		1
305	JPT310-305	Locking shoe		1
306	JPT310-306	Crank handle		1
307	JPT260-307	Crank handwheel		1
308	JPT260-308	Hex. Socket cap screw	M8X10	1
312	JPT310-312	Retaining ring	CLP20	1
313	JPT310-313	Retaining ring	CLP35	1
314	JPT310-314	Washer		1
315	JPT310-315	Crank bar		1
316	JPT310-316	Pan head screw	M6X12	2
317	JPT310-317	Washer	M6	2
318	JPT310-318	Bevel gear		1
319	JPT310-319	Retaining ring	CLP35	1
320	JPT310-320	Bearing	BRG80202	1
321	JPT310-321	Bevel gear bracket		1
322	JPT310-322	Washer	H8	8
323	JPT310-323	Hex. bolt	M8X35	8
324	JPT310-324	Thread rod		1
325	JPT310-325	Hex. bolt	M6X40	1
326	JPT310-326	Hex. nut	M6	1
327	JPT310-327	Hex. bolt	M8X35	2
329	JPT310-329	Washer	H8	2
330	JPT310-330	Thread rod bracket		1
331	JPT310-331	Column support		1
333	JPT310-333	Hex. Socket set screw	M8X20	5
335	JPT310-335	Column		1
336	JPT310-336	Hex. bolt	M10X35	2
337	JPT310-337	Spring washer	H10	2
338	JPT310-338	Thickness table		1
339	JPT310-339	Scale ring assembly		1
	6285917	Push Block (not shown)		1
	54A-T71E	Knife Gauge (not shown)		1

JPT-310 Working Fence Assembly

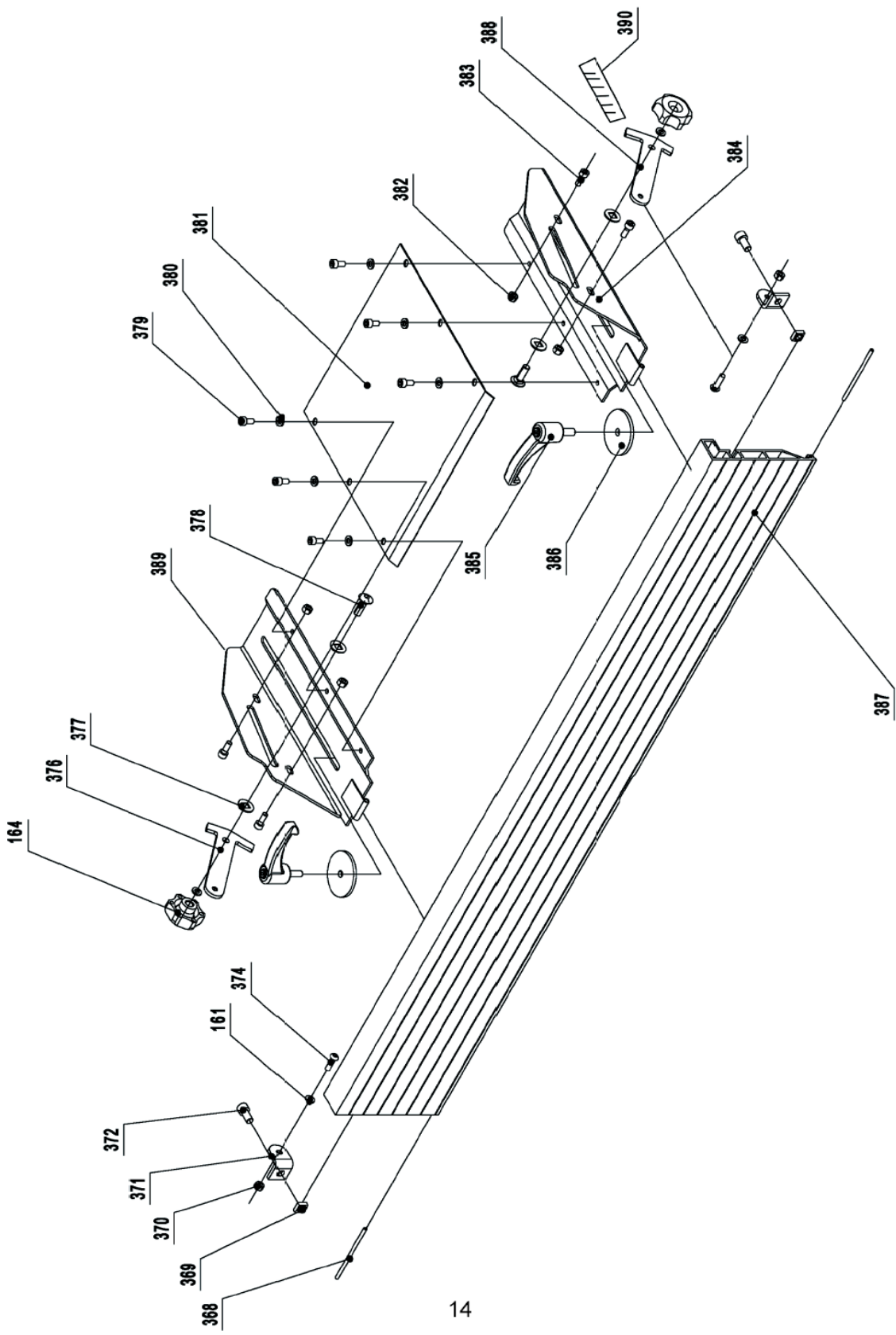

JPT-310 Working Fence Assembly

Index No.	Part No.	Description	Size	Qty
368	JPT310-368	Pin for hinge		1
369	JPT310-369	Square nut	M8	2
370	JPT310-370	Lock nut	M6	6
371	JPT310-371	Fence mounting bracket		2
372	JPT310-372	Hex. bolt	M8X16	2
374	JPT310-374	Hex. Socket cap screw	M6X16	2
376	JPT310-376	Fence support-right		1
377	JPT310-377	Nylon washer		10
378	JPT310-378	Carriage bolt	M8X25	2
379	JPT310-379	Pan head sscrew	M6X12	6
380	JPT310-380	Washer	H6	6
381	JPT310-381	Cutterblock cover		1
382	JPT310-382	Lock nut	M6	4
383	JPT310-383	Hex. Socket cap screw	M6X12	4
384	JPT310-384	Fence bracket-left		1
385	JPT310-385	Lock handle		2
386	JPT310-386	Special washer		2
387	JPT310-387	Fence		1
388	JPT310-388	Fence support-left		1
389	JPT310-389	Fence bracket-right		1
390	JPT310-390	Fence scale	M	1
391	JPT310-391	Complete fence assembly (368-390)		1

JPT-310-M

10000290M

	colour of strands	Litzenfarben	couleur des cordons
BK	black	schwarz	noir
WH	white	weiß	blanc
BU	blue	blau	bleu
YE	yellow	gelb	jaune
RD	red	rot	rouge
BN	brown	braun	brun
GY	grey	grau	gris
GNYE	green-yellow	grün-gelb	vert-jaune
OG	orange	orange	orange
VT	violet	violett	violet

	meaning of symbol	Bedeutung der Zeichen	interprétation
M	motor	Motor	moteur
S	switch	Schalter	interrupteur
C	condenser	Kondensator	condensateur
F	fuse	Sicherung	fusible
RS	reversing switch	Drehrichtungsschalter	commu. droite/gauche
CS	centrifugal switch	Fliehkraftschalter	déclencheur centrifuge
OL	overload cut-off	Überlastschuttschalter	déclencheur surcharge
LS1	limit switch	Positionsendschalter	micro
LS2	E-stop	Not-Aus Taster	arret d'urgence

1~230V, 50Hz

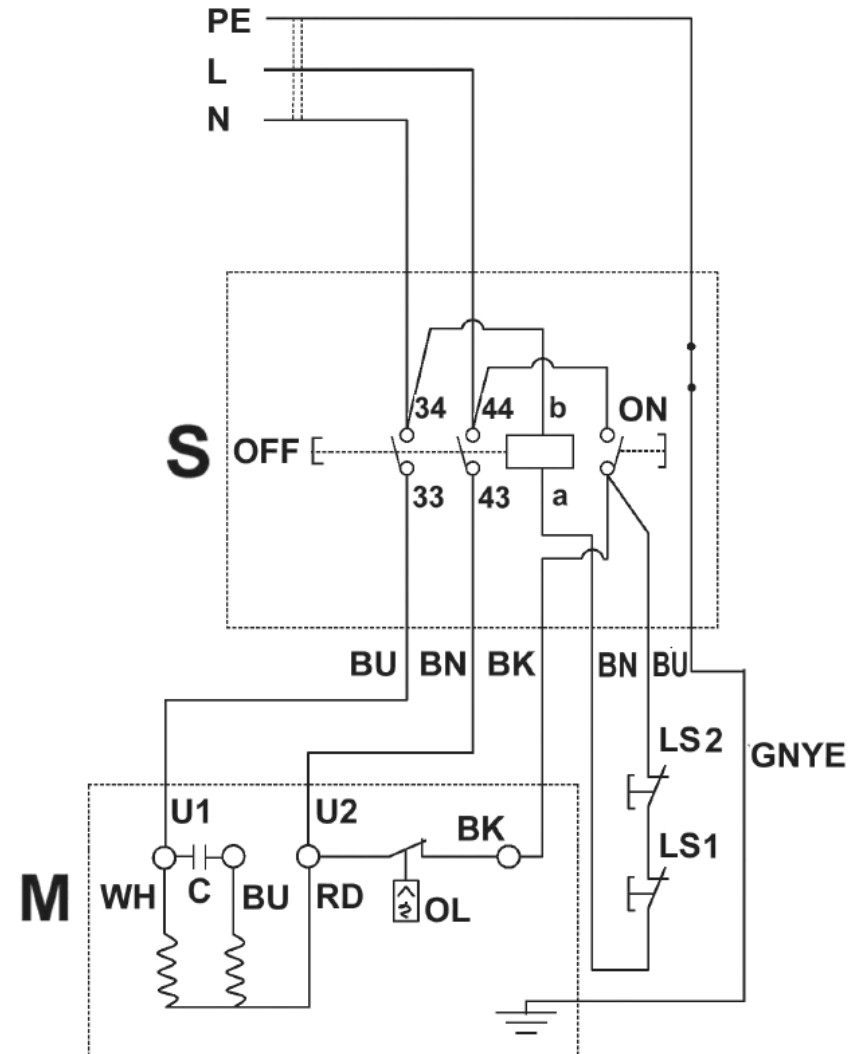

JPT-310-T

10000290T

	colour of strands	Litzenfarben	couleur des cordons
BK	black	schwarz	noir
WH	white	weiß	blanc
BU	blue	blau	bleu
YE	yellow	gelb	jaune
RD	red	rot	rouge
BN	brown	braun	brun
GY	grey	grau	gris
GNYE	green-yellow	grün-gelb	vert-jaune
OG	orange	orange	orange
VT	violet	violett	violet

	meaning of symbol	Bedeutung der Zeichen	interprétation
M	motor	Motor	moteur
S	switch	Schalter	interrupteur
C	condenser	Kondensator	condensateur
F	fuse	Sicherung	fusible
RS	reversing switch	Drehrichtungsschalter	commu. droite/gauche
CS	centrifugal switch	Fliehkraftschalter	déclencheur centrifuge
OL	overload cut-off	Überlastschuttschalter	déclencheur surcharge
LS1	Limit switch	Positionsendschalter	micro
LS2	E-stop	Not-Aus Taster	arret d'urgence

3~400V, 50Hz

