

JET

**JWL-1015
JWL-1015VS**

Wood Lathe

**JWL-1015-M.....719100M..1~230V,50Hz
JWL-1015VS-M..719110M..1~230V,50Hz**

PARTS LIST

JPW (Tool) AG
Tämperlistr. 5
CH-8117 Fällanden
Switzerland
Phone +41 44 806 47 48
Fax +41 44 806 47 58



www.jettools.com

P-719100M 2014 - 01

JWL-1015 Lathe – Exploded View

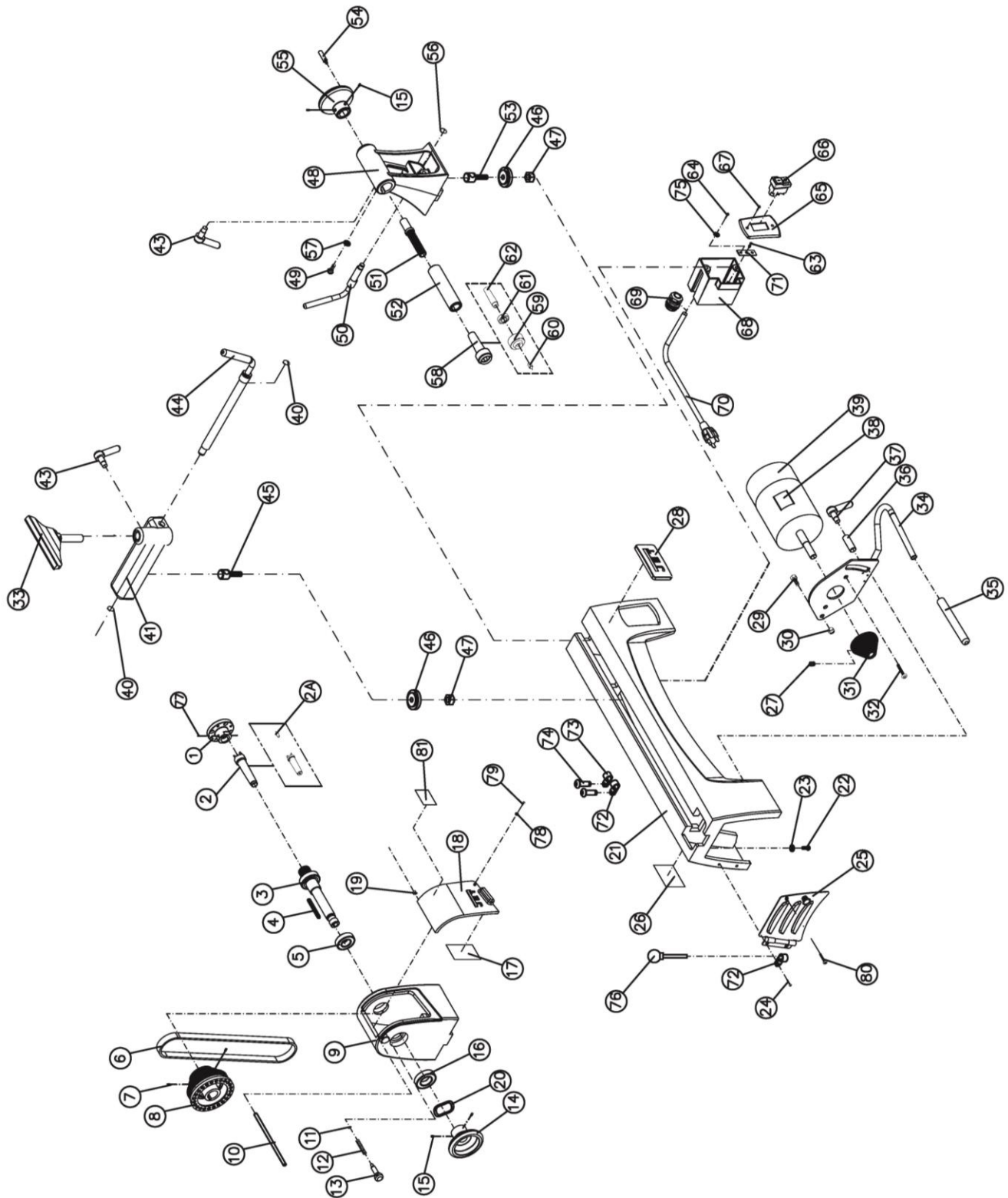

JWL-1015 Lathe – Parts List

Index No	Part No	Description	Size	Qty
	JWL1015-HAE	Headstock Assembly (<i>includes #3 thru #20,#81</i>)		1
1	6294736E	Faceplate	3", M33	1
2	JWL1642-102	Spur Center	MT2	1
2A	JML-3A	Center Point for Spur Center		1
3	JWL1015-103E	Spindle	M33x3.5mm	1
4	JML-5	Key	5x25mm	1
5	BB-6005VV	Ball Bearing	6005VV	1
6	JML-20	V-Belt	240J	1
7	TS-0267041	Socket Set Screw	1/4"-20x3/8"	2
8	JWL1015-108	Spindle Pulley		1
9	JWL1015-109E	Headstock		1
10	JWL1015-110	Pin		1
11	JML1014-187	C-Ring	STW-9	1
12	JML1014-188	Spring		1
13	JML1014-189	Index Pin		1
14	JWL1221VS-123	Handwheel		1
15	TS-0267021	Set Screw	1/4"-20x1/4"	4
16	BB-6004VV	Ball Bearing	6204VV	1
17	JWL1015-117E	Speed Label		1
18	JWL1015-118E	Pulley Access Door		1
19	JWL1015-119	Spring		1
20	JML-8	Wave Washer		1
21	JWL1015-121E	Bed		1
22	TS-0207061	Socket Head Cap Screw	1/4"-20x1"	4
23	TS-0720071	Lock Washer	1/4"	4
24	JWL1015-124	Socket Head Button Screw	#10-24x1/4"	2
25	JWL1015-125E	Motor Access Door		1
26	JWL1015-126E	I.D Label		1
27	TS-0267041	Socket Set Screw	1/4"-20x3/8"	2
28	JET-92	JET Logo with 3M Adhesive	92x38mm	1
29	TS-0051051	Hex Cap Screw	5/16"-18x1"	1
30	TS-0640081	Nylon Lock Hex Nut	5/16"-18	1
31	JML-28	Motor Pulley		1
32	JWL1015-132	Socket Head Flat Screw	1/4"-20x1/2"	2
33	JML-42	Tool Rest	6"	1
34	JWL1015-134	Motor Bracket		1
35	JWL1221VS-266	Rubber Cover		1
36	JWL1015-136	Bushing		1
37	JWL1015-137	Lock Handle Assembly, Motor Plate		1
38	JWL1015-138E	Motor Label		1
39	JWL1015-139E	Motor (Included #38)	1/2HP, 1Ph, 115V	1
	JML-35-1E	Capacitor (not shown)	12uf,400 VAC	1
	JML-35-2E	Capacitor Cover (not shown)		1
	JML-35-3	Motor Fan Cover (not shown)		1
	JWL1015-TBA	Toolrest Base Assembly (<i>includes #40 thru #47</i>)		2
40	JML-9	C-Ring	STW-12	2
41	JWL1015-141	Tool Rest Body		1
43	JML-59A	Lock Handle Assembly	5/16"-18x3/4"	2
44	JML-50	Eccentric Locking Rod		1
45	JML-43	Bolt		1
46	JML-44	Clamp		2
47	JML-81	Clamp Nut		2
	JWL1015-TA	Tailstock Assembly (<i>includes #15,43,46 thru #57</i>)		1
48	JWL1015-148	Tailstock		1
49	TS-0255031	Socket Head Button Screw	5/16"-18x5/8"	1
50	JML-58	Eccentric Rod, Tailstock		1
51	JWL1015-151	Lead Screw		1
52	JML-55	Quill		1
53	JML-64	Bolt		1
54	JWL1221VS-222	Handle		1

Index No	Part No	Description	Size	Qty
55	JWL1221VS-223	Handwheel		1
56	JML-63	C-Ring	STW-10	1
57	TS-0680031	Flat Washer	5/16"	1
58	708331	Live Center Assembly (<i>includes #59 thru #62</i>)		1
59	JML-52	Live Center Head		1
60	JML-52A	Center Point for Live Center		1
61	BB-6002ZZ	Ball Bearing	6002ZZ	1
62	JML-54	Live Center Shaft		1
63	JWL1015-163	Tapping Screw	M3.5x6mm	1
64	TS-1533032	Pan Head Screw	M5x10	2
65	JWL1015-165E	Switch Cover		1
66	JML-65E	On-Off Switch		1
67	TS-081C052	Pan Head Screw	#10-24x3/4"	2
68	JWL1015-168	Switch Box		1
69	JML-70E	Strain Relief		2
70	JWL1015-170E	Power Cord		1
71	JWL1015-171	Ground Plate		1
72	JWL1015-172	Clamp	5/16"	2
73	JWL1221VS-276	Clamp	1/2"	1
74	TS-081C022	Pan Head Screw	#10-24x3/8"	2
75	TS-0733041	External Tooth Lock Washer	1/4"	2
76	JML-11	Knockout Rod		1
77	6295796	Nylon Insert Socket Set Screw	1/4-20x3/8"	2
78	JWL1221VS-136E	O-Ring		1
79	TS-081C042	Screw	#10-24x5/8"	1
80	TS-081C022	Pan Head Screw	#10-24x3/8"	1
81	JWL1221VS-137E	Warning Label		1

JWL-1015VS Lathe – Exploded View

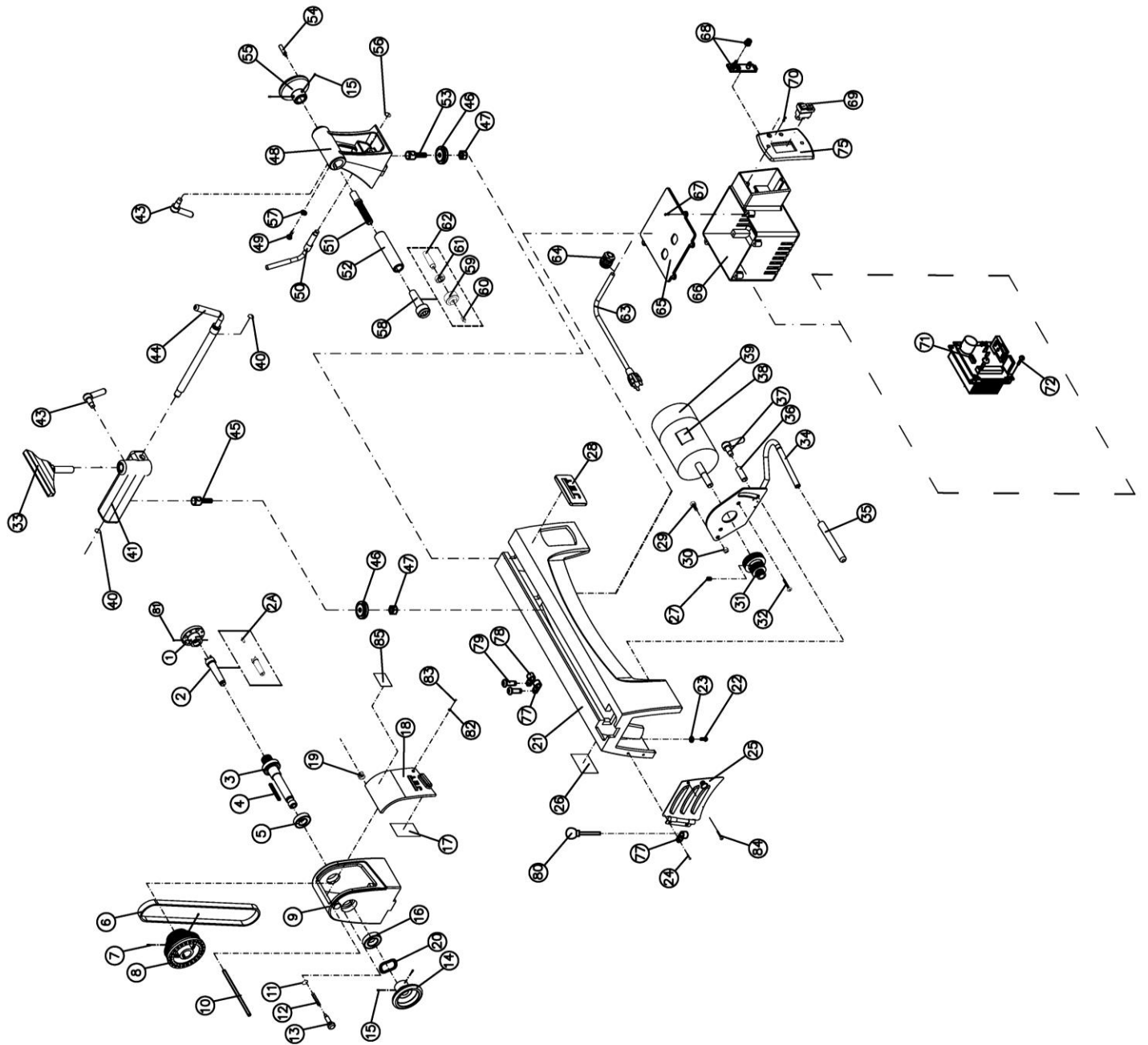

JWL-1015VS Lathe – Parts List

Index No	Part No	Description	Size	Qty
	JWL1015VS-HAE	Headstock Assembly (<i>includes #3 thru #2 & #85</i>)		1
1	JML-2	Faceplate	3"	1
2	JML-3	Spur Center	MT2	1
2A	JML-3A	Center Point for Spur Center		1
3	JWL1015-103E	Spindle	M33x3.5mm	1
4	JML-5	Key	5x25mm	1
5	BB-6005VV	Ball Bearing	6005VV	1
6	JML-20	V-Belt	240J	1
7	TS-0267041	Socket Set Screw	1/4"-20x3/8"	2
8	JWL1015VS-108	Spindle Pulley		1
9	JWL1015-109E	Headstock		1
10	JWL1015-110	Pin		1
11	JML1014-187	C-Ring	STW-9	1
12	JML1014-188	Spring		1
13	JML1014-189	Index Pin		1
14	JWL1221VS-123	Handwheel		1
15	TS-0267021	Set Screw	1/4"-20x1/4"	4
16	BB-6004VV	Ball Bearing	6204VV	1
17	JWL1015VS-117E	Speed Label		1
18	JWL1015-118E	Pulley Access Door		1
19	JWL1015-119	Spring		1
20	JML-8	Wave Washer		1
21	JWL1015-121E	Bed		1
22	TS-0207061	Socket Head Cap Screw	1/4"-20x1"	4
23	TS-0720071	Lock Washer	1/4"	4
24	JWL1015-124	Socket Head Button Screw	#10-24x1/4"	2
25	JWL1015-125E	Motor Access Door		1
26	JWL1015VS-126E	I.D Label		1
27	TS-0267041	Socket Set Screw	1/4"-20x3/8"	2
28	JET-92	JET Logo with 3M Adhesive	92x38mm	1
29	TS-0051051	Hex Cap Screw	5/16"-18x1"	1
30	TS-0640081	Nylon Lock Hex Nut	5/16"-18	1
31	JWL1015VS-131	Motor Pulley		1
32	TS-0254021	Socket Head Button Screw	1/4"-20x1/2"	2
33	JML-42	Tool Rest	6"	1
34	JWL1015-134	Motor Bracket		1
35	JWL1221VS-266	Rubber Cover		1
36	JWL1015-136	Bushing		1
37	JWL1015-137	Lock Handle Assembly, Motor Plate		1
38	JWL1015VS-138E	Motor Label		1
39	JWL1015VS-139E	Motor	1/2 HP	1
	JWL1015VS-MCB	Motor Carbon Brush with Cap (not shown)		2
	JWL1015VS-MFC	Motor Fan Cover (not shown)		1
	JWL1015VS-MF	Motor Fan (not shown)		1
	JWL1015-TBA	Toolrest Base Assembly (<i>includes #40 thru #47</i>)		2
40	JML-9	C-Ring	STW-12	2
41	JWL1015-141	Tool Rest Body		1
43	JML-59A	Lock Handle Assembly	5/16"-18x3/4"	2
44	JML-50	Eccentric Locking Rod		1
45	JML-43	Bolt		1
46	JML-44	Clamp		2
47	JML-81	Clamp Nut		2
	JWL1015-TA	Tailstock Assembly (<i>includes #15,43,46 thru #57</i>)		1
48	JWL1015-148	Tailstock		1
49	TS-0255031	Socket Head Button Screw	5/16"-18x5/8"	1
50	JML-58	Eccentric Rod, Tailstock		1
51	JWL1015-151	Lead Screw		1
52	JML-55	Quill		1
53	JML-64	Bolt		1
54	JWL1221VS-222	Handle		1

Index No	Part No	Description	Size	Qty
55	JWL1221VS-223	Handwheel		1
56	JML-63	C-Ring	STW-10	1
57	TS-0680031	Flat Washer	5/16"	1
58	708331	Live Center Assembly (includes #59 thru #62)		1
59	JML-52	Live Center Head		1
60	JML-52A	Center Point for Live Center		1
61	BB-6002ZZ	Ball Bearing	6002ZZ	1
62	JML-54	Live Center Shaft		1
	JWL1015VS-CAE	Controller Assembly (includes #63 thru #75)		1
63	JWL1015VS-163E	Power Cord		1
64	JML-70E	Strain Relief		2
65	JWL1015VS-165E	Plate		1
66	JWL1015VS-166	Switch Cover		1
67	JWL1015VS-167	Tapping Screw	M3x12	4
68	JWL1015VS-168E	Control Potentiometer Assembly		1
69	JML-65E	On-Off Switch		1
70	JWL1015VS-170	Tapping Screw		2
71	JWL1015VS-171E	Circuit Board Assembly		1
72	JWL1221VS-302	Tapping Screw	M3x19	4
73	JWL1015VS-174	Connect Cord (VR to PC board; not shown)		1
74	JWL1221VS-324	Connect Cord (Power cord to PC board; not shown)		1
75	JWL1015VS-175E	Switch Cover		1
77	JWL1015-172	Clamp	5/16"	2
78	JWL1221VS-276	Clamp	1/2"	1
79	TS-081C022	Pan Head Screw	#10-24x3/8"	2
80	JML-11	Knockout Rod		
81	6295796	Nylon Insert Socket Set Screw	1/4-20x3/8"	2
82	JWL1221VS-136E	O-Ring		1
83	TS-081C042	Screw	#10-24x5/8"	1
84	TS-081C022	Pan Head Screw	#10-24x3/8"	1
85	JWL1221VS-137E	Warning Label		1

JWL-1015-M.....719100M....1~230V,50Hz

	colour of strands	Litzenfarben	couleur des cordons
BK	black	schwarz	noir
WH	white	weiß	blanc
BU	blue	blau	bleu
YE	yellow	gelb	jaune
RD	red	rot	rouge
BN	brown	braun	brun
GY	grey	grau	gris
GNYE	green-yellow	grün-gelb	vert-jaune
OG	orange	orange	orange
VT	violet	violett	violet

	meaning of symbol	Bedeutung der Zeichen	interprétation
M	motor	Motor	moteur
S	switch	Schalter	interrupteur
C	condenser	Kondensator	condensateur
E	electronic unit	Elektronik Einheit	unité électronique
F	fuse	Sicherung	fusible
RS	reversing switch	Drehrichtungsschalter	commu. droite/gauche
CS	centrifugal switch	Fliehkraftschalter	déclencheur centrifuge
OL	overload cut-off	Überlastschuttschalter	déclencheur surcharge
LS	limit switch	Positionsendschalter	micro

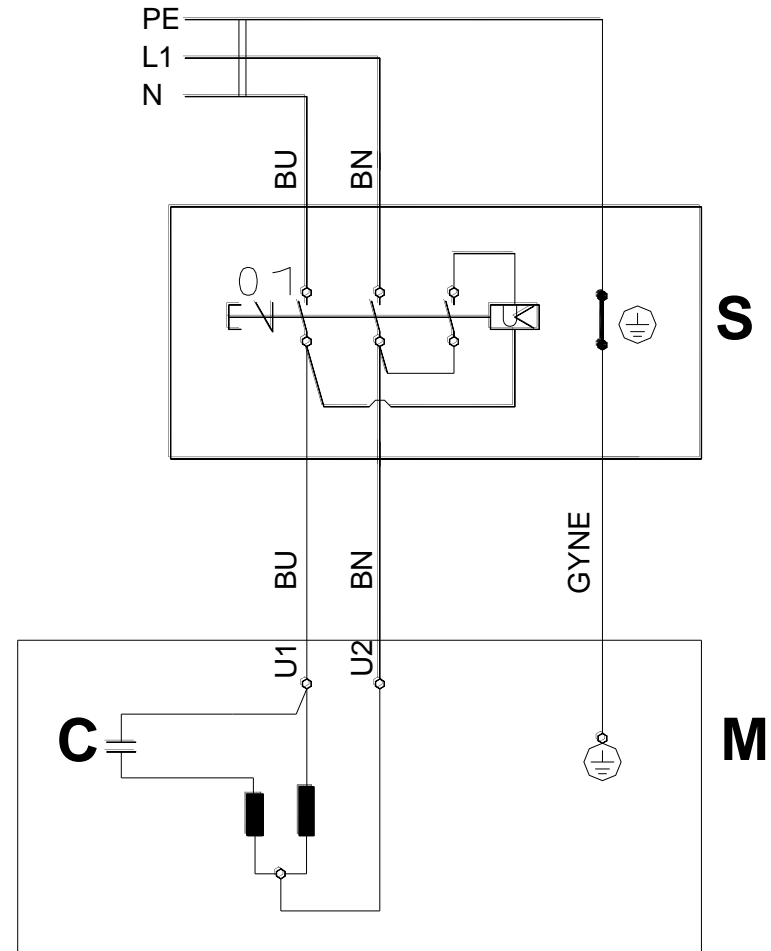

JWL-1015VS-M..719110M....1~230V,50Hz

	colour of strands	Litzenfarben	couleur des cordons
BK	black	schwarz	noir
WH	white	weiß	blanc
BU	blue	blau	bleu
YE	yellow	gelb	jaune
RD	red	rot	rouge
BN	brown	braun	brun
GY	grey	grau	gris
GNYE	green-yellow	grün-gelb	vert-jaune
OG	orange	orange	orange
VT	violet	violett	violet

	meaning of symbol	Bedeutung der Zeichen	interprétation
M	motor	Motor	moteur
S	switch	Schalter	interrupteur
C	condenser	Kondensator	condensateur
E	electronic unit	Elektronik Einheit	unité électronique
F	fuse	Sicherung	fusible
RS	reversing switch	Drehrichtungsschalter	commu. droite/gauche
CS	centrifugal switch	Fliehkraftschalter	déclencheur centrifuge
OL	overload cut-off	Überlastschuttschalter	déclencheur surcharge
LS	limit switch	Positionsendschalter	micro

