



# Precision Trak & Stop Kit

ITEM# KMS8000

## INSTRUCTION MANUAL

MANUEL D'INSTRUCTIONS

MANUAL DE INSTRUCCIONES

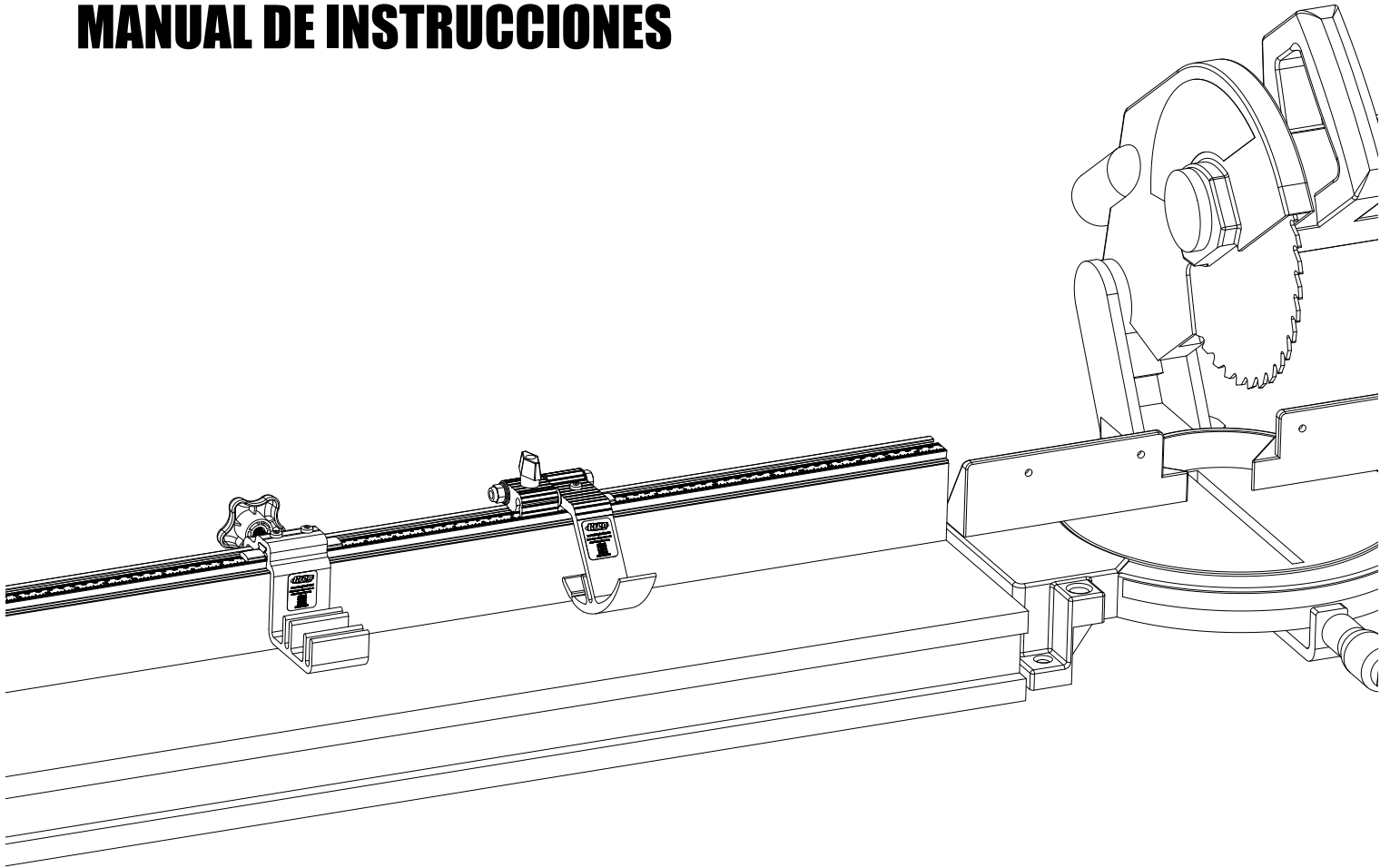

## 1. Top Trak

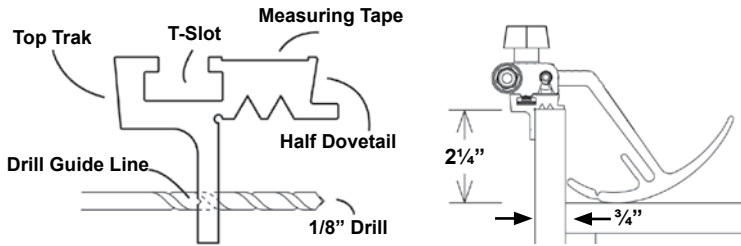

At the heart of the Precision Trak & Stop Kit is the Kreg Top Trak. Top Trak attaches to your 3/4" thick fence component such as melamine, plywood, or other suitable material. A recessed area on top of the track allows you to attach the Measuring Tape while the T-slot provides a means to guide and anchor the Swing Stop™. The Half Dovetail profile on the front and back of the track anchors the Production Stop. The fence component must be 3/4" x 2-1/4" for the Top Trak, Swing Stop™, and Production Stop to function properly. A groove in the rear of the track functions as a drill guide. Drill a 1/8" screw hole, 1" from each end, then space the remaining screw holes evenly between the outside holes for a total of 4 or 5 screws per each 2-foot section. To "connect" the 2-foot Top Trak pieces to form a 4-ft, 6-ft, or 8-ft section simply butt the adjoining pieces and mount in place.

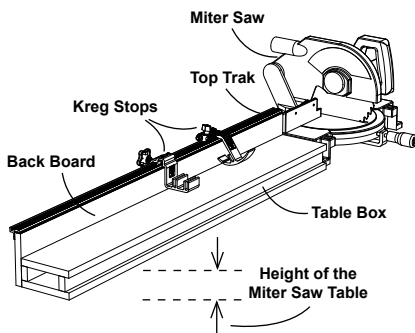

One of the most common applications for the Precision Trak & Stop Kit is combined with a miter saw. The table design, shown at left allows you to customize the table height for your saw. The table box height should be the same as the height of the miter saw table. Table boxes can be placed to the left or right of the miter saw and will support the material being cut as well as provide a mounting surface for the Top Trak.

The image below shows an expanded view of the end profile of the image above. The height of the back board should be the height of the table box PLUS 2-1/4". The example below shows a table box that is constructed using pocket hole joinery and pocket hole screws (sold separately). Although this is an effective method of construction for this application it is not the only method that may be utilized. The vertical members that are sized for the miter saw table height are attached to the table box top with pocket hole screws in 15-degree pocket holes. The bottom and the back are attached with pocket hole screws. If you want to learn more about pocket hole joinery consult your local Kreg dealer or visit us on the Web at [www.kregtool.com](http://www.kregtool.com).

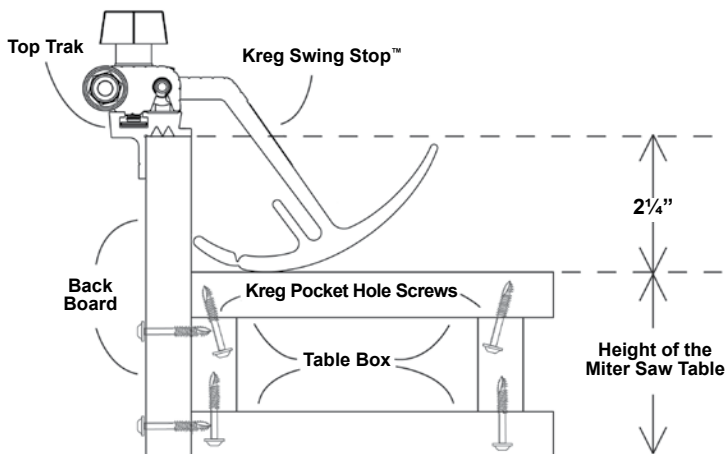

## 2. Production Stop

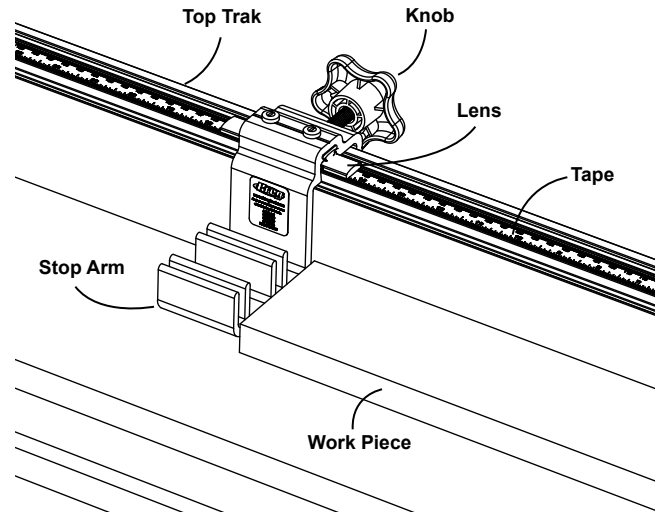

The Production Stop measures and records the distance between the end of the board and the saw blade, drill bit or router cutter. This allows you to easily cut multiple pieces of stock to the exact same length. Cutting numerous pieces to the exact length without measuring is easy. Gently press the end of the board opposite the blade against the side of the stop arm as shown at left. The Production Stop can be secured anywhere along the Top Trak, easily lifted off the top of the track and repositioned on the opposite side of the blade. The Production Stop features two adjustable lens cursors that can be set independently to read accurately off of either side of the blade.

### ASSEMBLE THE STOP

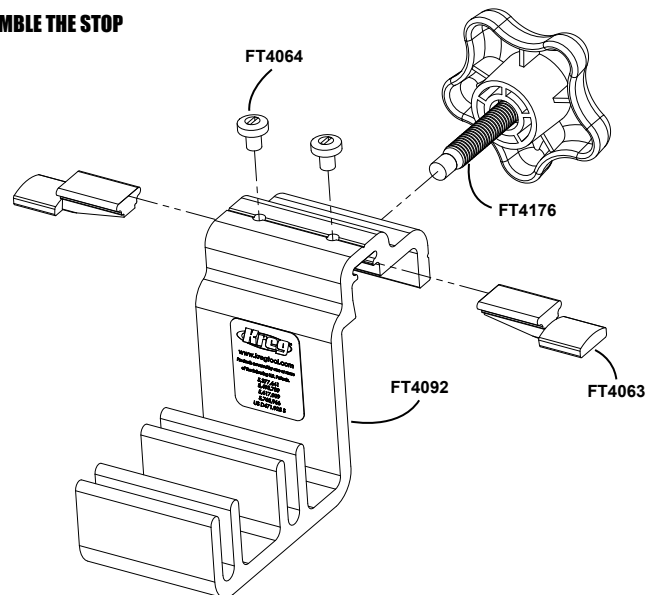

Part#	Qty.	Description
FT4092	1	Stop Arm
FT4063	2	Lens
FT4064	2	10-32 x 1/4" Nylon Screw
FT4176	1	Threaded Knob

\*Please see step 4. Measuring Tape for setting the cursor correctly on your stops.

## 3. Swing Stop™

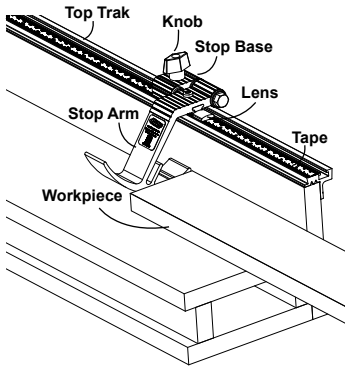

The Swing Stop™ measures and records the distance between the end of the board and the saw blade, drill bit or router cutter. This allows you to easily cut multiple pieces of stock to the exact same length. Cutting numerous pieces to the exact length without measuring is easy. Gently press the end of the board opposite the blade against the side of the stop arm as shown at left. The Swing Stop™ can be secured anywhere along the track. The Swing Stop™ arm can be assembled on either side of the Stop Base although it must be positioned between the Stop Base and the saw blade.

The curved Swing Stop™ arm is designed to rise automatically when a board is pushed against the front of the stop arm as shown at left. The Swing Stop™ arm rests on top of the work piece until the board underneath is removed. When the board is removed or moved to the side of the Swing Stop™ the Stop arm drops down and is again ready to be used as a stop.

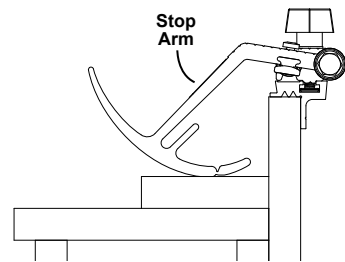

### ASSEMBLE THE STOP

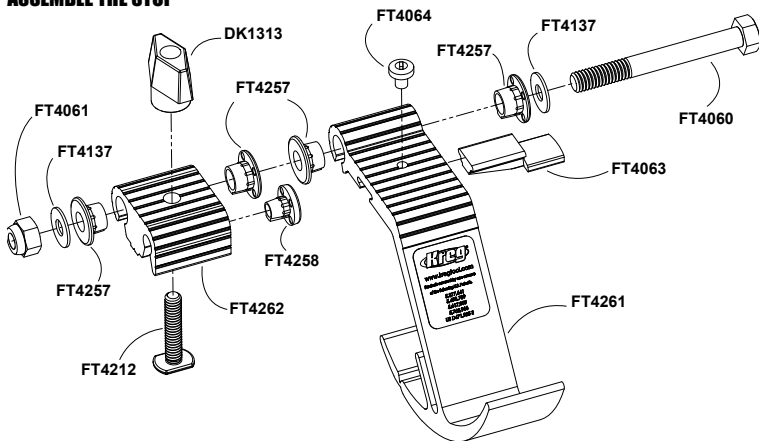

Part#	Qty.	Description
FT4261	1	<b>Swing Stop™ Arm</b> - Position on side of stop base nearest blade
FT4063	1	<b>Lens</b> - Allows precise adjustment of Swing Stop™
FT4061	1	<b>Nyloc Nut</b> - Won't work loose during use
FT4137	2	<b>Brass Washer</b> - Protects the Plastic Stop Bushing
FT4064	1	<b>Nylon Screw</b> - Used to calibrate lens zero position
DK1313	1	<b>Black T-Knob</b> - Tightens Swing Stop™ assembly in position
FT4060	1	<b>Hex Head Bolt</b> - Secures Swing Stop™ assembly
FT4262	1	<b>Stop Base</b> - Anchors assembly to aluminum trak
FT4212	1	<b>T-Bolt</b> - Slides in T-Slot of aluminum trak
FT4257	4	<b>Plastic Stop Bushing</b> - Allows for smooth operation
FT4258	1	<b>Plastic Support Button</b> - Allows for smooth operation

\*Please see **step 4. Measuring Tape** for setting the cursor correctly on your stops.

## 4. Measuring Tape

### Locate the Measure Tape

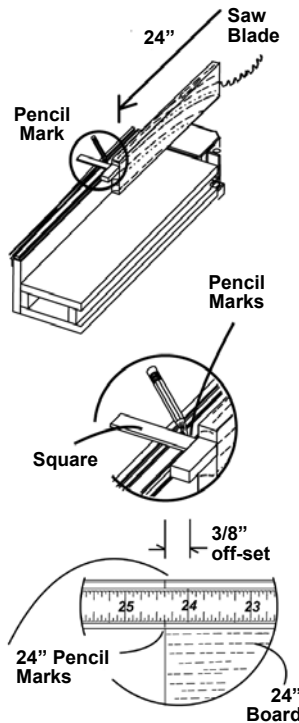

1. Cut a straight 3/4" thick piece of material exactly 24" long by 3" wide.

2. Turn the board on edge and place the board with one end against the teeth of the saw blade as shown at left.

3. Use a square or similar layout tool to place a pencil mark across the top of the fence onto the Top Trak on either side of the indentation for the Self Adhesive Measuring Tape. Butt the square against the reference board so that the pencil marks will be exactly 24" from the blade as shown. If you have placed Top Trak on both sides of the blade repeat the same process for the other side of the blade.

4. **Align the 24-3/8" mark of the Self Adhesive Measuring Tape to the pencil mark** and adhere the Tape to the indentation along the length of the Top Trak. Cutoff excess tape with scissors.

**Note:** Placing the Tape is much easier if you slice the backing of the Measuring Tape under the 24" mark and fold over to expose only a short amount of the adhesive.

### About the Lens

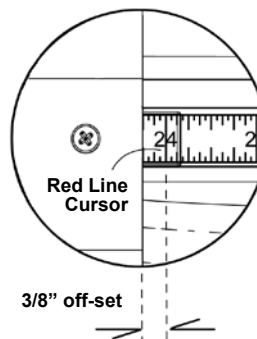

Both the Production Stop and the Swing Stop™ feature an adjustable lens cursor similar to the lens on a quality table saw rip fence.

The lens is a clear material except for a red line (cursor) on the bottom of the lens as shown at left. The red line cursor makes it easy to read the tape lines and fine-tune the stop when compensating for blade thickness variations or a tape that is not perfectly positioned.

**Note:** When placing the self-adhesive tape onto the track, the tape must be placed **3/8" CLOSER TO THE SAW BLADE** to allow the Lens to function properly.

### Set the Cursor

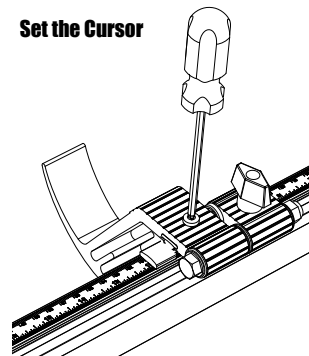

1. Adjust the cursor so it sits about 3/8" from the edge of the stop. The cursor set screw is on top of the stop arm.
2. Measure a piece of scrap wood. The exact length of this scrap is not important. A board about 24" works well because it gives you plenty of room to make some test cuts.
3. Set the stop so the cursor reads a length less than the length of the scrap piece.
4. Cut the scrap board to the new length and measure the cut board.
5. Without moving the stop loosen the cursor set screw and adjust it to read this exact measurement.