



Operating manual

Version 1.0.9

Grinding machine for burins and tools

OPTigrind[®]
GH 20T

Item no. 310 0125





Table of contents

1	Safety	
1.1	Representation Conventions	5
1.2	Safety instructions (warning notes).....	6
1.2.1	Classification of hazards	6
1.2.2	Other pictograms.....	7
1.3	Intended use	7
1.4	Possible dangers caused by the grinding machine for burins	8
1.5	Qualification of personnel	8
1.5.1	Target group.....	8
1.5.2	Authorized personnel	9
1.6	Operators positions.....	9
1.7	Safety measures during operation.....	10
1.8	Safety devices	10
1.9	Safety check	10
1.9.1	ON / Off - Switch	11
1.9.2	Spark protection.....	11
1.10	Personal protective equipment for special works	11
1.11	Safety during operation.....	11
1.12	Accident report.....	12
1.13	Electrical system.....	12
2	Technical data	
2.1	Electrical connection.....	13
2.2	Speed	13
2.3	Adjustable angle	13
2.4	Travels	13
2.5	Grinding wheels	13
2.6	Grinding devices	13
2.7	Collet seat.....	13
2.8	Dimensions	13
2.9	Environmental conditions.....	13
2.10	Emissions	13
2.11	Dimensions cup wheel.....	14
3	Assembly	
3.1	Scope of delivery	15
3.2	Storage	16
3.3	Installation and assembly	17
3.3.1	Requirements regarding the installation site	17
3.3.2	Electrical connection	17
3.3.3	Assembly.....	17
3.4	First commissioning	18
4	Operation	
4.1	Safety.....	19
4.2	Assembly and function.....	21
4.3	Handling the tool holder.....	22
4.4	Setting the shaft shoulder	23
4.5	Grinding angles.....	24
4.6	Assembling the devices	25
4.6.1	Grinding device for drill bit.....	25
4.6.2	Grinding device turning tool	26
4.6.3	Grinding device end mill.....	27
5	Maintenance	
5.1	Safety.....	28
5.1.1	Preparation.....	28
5.1.2	Restarting.....	28
5.2	Inspection and maintenance.....	29
5.2.1	Exchange of the abrasive wheel	29
5.3	Repair	30
5.3.1	Customer service technician	30
6	Ersatzteile - Spare parts	
6.1	Ersatzteilbestellung - Ordering spare parts	31
6.2	Hotline Ersatzteile - Spare parts Hotline	31
6.3	Service Hotline.....	31
6.4	Ersatzteilzeichnungen - Spare part drawings	32
6.5	Schaltplan - Wiring diagram.....	36



7 Annex

7.1	Copyright	37
7.2	Terminology/Glossary	37
7.3	Change information manual	37
7.4	Product follow-up	38
7.5	Liability claims for defects / warranty	38
7.6	Advice for disposal / Options of re-use	38
	7.6.1 Decommissioning	39
	7.6.2 Disposal of the packaging of the new machine	39
	7.6.3 Disposal of the used machine	39
	7.6.4 Disposal of electrical and electronic components	39
7.7	Disposal via municipal collecting points	40



Preface

Dear customer,

Thank you very much for purchasing a product made by OPTIMUM.

OPTIMUM metal working machines offer a maximum of quality, technically optimum solutions and convince by an outstanding price performance ratio. Continuous enhancements and product innovations guarantee state-of-the-art products and safety at any time.

Before commissioning the machine please thoroughly read these operating instructions and get familiar with the machine. Please also make sure that all persons operating the machine have read and understood the operating instructions beforehand.

Keep these operating instructions in a safe place nearby the machine.

Information

The operating instructions include indications for safety-relevant and proper installation, operation and maintenance of the machine. The continuous observance of all notes included in this manual guarantee the safety of persons and of the machine.

The manual determines the intended use of the machine and includes all necessary information for its economic operation as well as its long service life.

In the paragraph "Maintenance" all maintenance works and functional tests are described which the operator must perform in regular intervals.

The illustration and information included in the present manual can possibly deviate from the current state of construction of your machine. Being the manufacturer we are continuously seeking for improvements and renewal of the products. Therefore, changes might be performed without prior notice. The illustrations of the machine may be different from the illustrations in these instructions with regard to a few details. However, this does not have any influence on the operability of the machine.

Therefore, no claims may be derived from the indications and descriptions. Changes and errors are reserved!

Your suggestion with regard to these operating instructions are an important contribution to optimising our work which we offer to our customers. For any questions or suggestions for improvement, please do not hesitate to contact our service department.

If you have any further questions after reading these operating instructions and you are not able to solve your problem with a help of these operating instructions, please contact your specialised dealer or directly the company OPTIMUM.

Optimum Maschinen Germany GmbH

Dr.- Robert - Pflieger - Str. 26

D-96103 Hallstadt

Mail: info@optimum-maschinen.de

Internet: www.optimum-maschinen.com



1 Safety





1.1 Representation Conventions

 gives additional advices



 calls on you to act

 enumerations

This part of the operating instructions

-  explains the meaning and use of the warning notices included in these operating instructions,
-  defines the intended use of the grinding machine for burins,
-  points out the dangers that might arise for you or others if these instructions are not observed,
-  informs you about how to avoid dangers.

In addition to these operation instructions, please observe

-  the applicable laws and regulations,
-  the legal regulations for accident prevention.

When installing, operating, maintaining and repairing the grinding machine for burins it is necessary to observe the European standards

The still applicable country-specific regulations need to be applied for the not yet for the corresponding national country law implemented German standards.

If required it is necessary to take the corresponding measures to comply with the country-specific regulations before commissioning the grinding machine for burins.

Please keep this documentation always close to the grinding machine for burins.

INFORMATION

If you are unable to solve a problem using these operating instructions, please contact us for advice:

Optimum Maschinen Germany GmbH

Dr. Robert-Pfleger-Str. 26

D- 96103 Hallstadt





1.2 Safety instructions (warning notes)

1.2.1 Classification of hazards

We classify the safety instructions into different levels. The table below gives an overview of the classification of symbols (pictograms) and signal words for the specific danger and its (possible) consequences.

Pictogram	Signal word	Definition/Consequences
	DANGER!	Imminent danger that will cause severe injury or death to the staff.
	WARNING!	A danger that might cause severe injury to the staff or can lead to death.
	CAUTION!	Danger of unsafe procedure that might cause injury to the staff or property damages.
	ATTENTION!	Situation that could cause damage to the machine and products and other types of damage. No risk of injury to the staff.
	INFORMATION	Application tips and other important or useful information and notes. No dangerous or harmful consequences for the staff or objects.

In case of specific dangers, we replace the pictogram by





1.2.2 Other pictograms



Warning of flammable substances!



Disconnect the mains plug!



Activation forbidden!



Use protective glasses!



Use protective boots!



Contact address



Protect the environment!

1.3 Intended use

Use

The grinding machine for burins is designed and manufactured to be used in a non-explosive environment. The grinding machine for burins must only be used to manufacture single edge milling cutters, stamps and to regrind tools, cutting tools such as end milling cutters, drills, TIG welding electrodes, etc.

If the grinding machine for burins is used in any way other than described above, modified without the approval of the company Optimum Maschinen Germany GmbH or used in any other way then the grinding machine for burins is being used improperly.

We do not take any liability for damages caused by improper use.

We expressly point out that the guarantee or CE conformity will expire due to any constructive technical or procedural changes which had not been performed by the company Optimum Maschinen Germany GmbH.

It is also part of intended use that you

- observe the operating values and setting of the data grinding machine for burins,
- observe the operating instructions,
- observe the inspection and maintenance instructions.

📖 Technical data on page 13



1.4 Possible dangers caused by the grinding machine for burins

The grinding machine for burins is state-of-the-art.

Nevertheless, there is a residual risk as the grinding machine for burins operates with

- at high speeds,
- rotating parts,
- with an abrasive wheel (flying sparks)
- with electrical voltages and currents.

We have used construction resources and safety techniques to minimize the health risk for the staff resulting from these hazards.

If the grinding machine for burins is used and maintained by the staff who are not duly qualified, there may be a risk resulting from incorrect or unsuitable maintenance of the grinding machine for burins.

INFORMATION

All staff involved in assembly, commissioning, operation and maintenance, must

- be duly qualified,
- strictly follow these operating instructions.

In the event of intended use

- there may be a risk to the persons,
- there may be a risk to the grinding machine for burins and other material values,
- the correct function of the grinding machine for burins may be affected.

Always disconnect the mains plug from the socket before performing any cleaning or maintenance works.



1.5 Qualification of personnel

1.5.1 Target group

This manual is addressed to

- the operating companies,
- the operators,
- the staff for maintenance works.

Therefore, the warning notes refer to both, operation and maintenance staff of the grinding machine for burins.

Determine clearly and explicitly who will be responsible for the different activities on the machine (operation, maintenance and repair).

Unclear responsibilities constitute a safety risk!

The qualifications of the staff for the different tasks are mentioned below:

Operator

The operator is instructed by the operating company about the assigned tasks and possible risks in case of improper behaviour. Any tasks which need to be performed beyond the operation in the standard mode must only be performed by the operator if it is indicated in these instructions and if the operating company expressly commissioned the operator.

Electrical specialist

Due to his professional training, knowledge and experience as well as his knowledge of respective standards and regulations the electrical specialist is able to perform works on the electrical system and to recognise and avoid any possible dangers himself.



The electrical specialist is specially trained for the working environment in which he is working and knows the relevant standards and regulations.

Specialist staff

Due to its professional training, knowledge and experience as well as his knowledge of relevant regulations the specialist staff is able to perform the assigned tasks and to recognise and avoid any possible dangers himself.

Instructed persons

Instructed persons were instructed by the operating company about the assigned tasks and any possible risks in case of improper behaviour.

1.5.2 Authorized personnel

WARNING!

Incorrect use and maintenance of the grinding machine for burins constitutes a danger for the staff, objects and the environment.



Only authorized staff may operate the grinding machine for burins and tools!

Persons authorized to operate and maintain should be trained technical personnel and instructed by the ones who are working for the operating company and for the manufacturer.

The operating company must

- train the personnel,
- instruct the personnel in regular intervals (at least once a year) on
 - all safety standards that apply to the machine,
 - the operation,
 - accredited technical guidelines,
- check personnel's state of knowledge,
- document the trainings/instructions,
- require personnel to confirm participation in training/instructions by means of a signature,
- check whether the personnel is working safety- and risk-conscious and observe the operating instructions.

Obligations of the of the operating company,

The operator must

- have followed a training on the operation of the grinding machine for burins,
- know the function and performance,
- before taking the machine in operation
 - have read and understood the operating instructions,
 - be familiar with all safety devices and instructions.

Obligations of the operator

For work on the following parts there are additional requirements:

- Electrical parts or operating agents: shall only be performed by an electrician or under the guidance and supervision of an electrician.
- Before starting work on electrical parts or operating agents, following measures are to be performed in the following order.
 - ➔ Disconnect all poles.
 - ➔ Secure against switching on.
 - ➔ Check if the machine is zero potential.

Additional requirements regarding the qualification

1.6 Operators positions

The operator's position is in front of the grinding machine for burins.



INFORMATION

The mains plug of the grinding machine for burins must be freely accessible.



1.7 Safety measures during operation

CAUTION!

Risk by inhaling health hazardous dusts and fogs.

Depending on the materials which need to be treated and the agents which are used, dusts and fogs may be generated which endanger your health.

Make sure that the generated health hazardous dusts and fogs are safely sucked-off at the place of origin and that they are dissipated or filtered. To do so, use a suitable extraction unit.



CAUTION!

Risk of fire and explosion by using inflammable materials or cooling-lubricating agents.

Before processing inflammable materials (e.g. aluminium, magnesium) or using inflammable auxiliary materials (e.g. spirit) it is necessary to take additional preventive measures in order to safely avoid health risks.



1.8 Safety devices

Use the grinding machine for burins only with properly functioning safety devices.

Stop the grinding machine for burins immediately if there is a failure on the safety device or if it is not functioning for any reason. It is your responsibility!

If a safety device has been activated the grinding machine for burins must only be used if you

- have removed the cause of the failure,
- have verified that there is no danger resulting for the staff or objects.

WARNING!

If you bypass, remove or deactivate a safety device in any other way, you are endangering yourself and other staff working with the grinding machine for burins and tools.



The possible consequences are:

- extremely serious injuries by bursting of the abrasive wheel,
- injury of eyes due to flying sparks,
- injury of hands,
- a fatal electrocution.

WARNING!

The separating protective covers which are made available and delivered together with the machine are designed to reduce the risk of workpieces or fragments of tools or workpieces flying off at high speed - however, this cannot be completely avoided. Always work carefully and observe the limit values of your grinding process.



1.9 Safety check

Check the grinding machine for burins before each start-up or at least once per shift. Inform the person responsible immediately of any damage, defect or change in operating function.

Check all safety devices

- at the beginning of each shift (at continuous operation),
- once a week (with the machine in operation),
- after every maintenance and repair work.



Check that prohibition, warning and information signs and the labels on the grinding machine for burins

- are legible (clean them, if necessary),
- are complete (replace if necessary).

INFORMATION

Use the following table for organizing the checks.



General check		
Equipment	Check	OK
Protective covers	Mounted, firmly bolted and not damaged	
Signs, Markings	Installed and legible	
Date:	Checked by (signature):	

Functional test		
Equipment	Check	OK
ON-OFF switch	The grinding machine for burins must only be restarted after having disconnected and reconnected the mains plug if the ONswitch was pressed again.	
Date:	Checked by (signature):	

1.9.1 ON / Off - Switch

Switches the burin grinder On or Off..

1.9.2 Spark protection

The protective cover of the abrasive wheel reduces the number of flying sparks getting into your eyes during machining.

Use protective glasses!



1.10 Personal protective equipment for special works

Protect your face and eyes: wear a safety helmet with facial protection when performing works where your face and eyes are exposed to hazards.



Wear safety shoes when carrying the grinding machine for burins.



1.11 Safety during operation

We specially point out the specific dangers when working with and on the grinding machine for burins and tools.

WARNING!

Before switching on the grinding machine for burins, make sure that there are

- no dangers generated for persons,
- no objects are damaged.





WARNING!

Fire and explosion due to sparks.

- Do not operate the grinding machine for burins and tools nearby combustible or explosive material.



Avoid any risky working practices:

- Make sure that nobody is endangered by your work.
- Wear safety goggles.
- The instructions mentioned in these operating instructions have to be strictly observed during assembly, operation, maintenance and repair.
- Do not work on the grinding machine for burins, if your concentration is reduced, for example, because you are taking medication.
- Observe the accident prevention regulations issued by your Employers Liability Insurance Association or other competent supervisory authority, responsible for your company.
- Inform the supervisor about all endangerments or errors.

1.12 Accident report

Inform your superiors and Optimum Maschinen Germany GmbH immediately in the event of accidents, possible sources of danger and any actions which almost led to an accident (near misses).

There are many possible causes for "near misses".

The sooner they are notified, the faster the causes can be eliminated.

INFORMATION

We highlight specific dangers when performing works on the grinding machine for burins and tools in the description of that work.



1.13 Electrical system

🔌 Schaltplan - Wiring diagram on page 36

Have the machine and/or the electrical equipment checked regularly, at least every six months.

Immediately eliminate all defects such as loose connections, defective wires, etc.

A second person must be present during work on live components to disconnect the power in the event of an emergency.

Immediately disconnect the grinding machine for burins and tools if there are any anomalies in the power supply!



2 Technical data

The following information are the dimensions and indications of weight and the manufacturer's approved machine data.

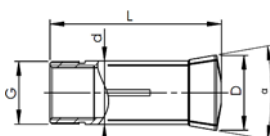
2.1 Electrical connection	
Motor power	3x400 V / 50Hz / 370 W
2.2 Speed	
Speed grinding disc, diamond disc	5000 min ⁻¹ at ~50Hz connection
Speed grinding disc, diamond disc	6000 min ⁻¹ at ~60Hz connection
Grinding speed	35 m/s (~50Hz) 42 m/s (~60Hz)
Motor speed	2750 min ⁻¹ (~50Hz) 3300 min ⁻¹ (~60Hz)
2.3 Adjustable angle	
Vertical / rear	0- 40°
Horizontal /taper grinding	0-180°
Negative	0- 52°
Setting positions rotation angle	22 x 15° (2 stop points assigned for regrinding drill)
	180°
2.4 Travels	
Travel tool holder	140mm
Fine adjustment range tool holder	18mm
Fine adjustment range length axis	6mm
Division scale infeed	0.01mm
2.5 Grinding wheels	
Corundum cup wheel	Ø100 x 50 x Ø20
Diamond cup wheel	Ø100 x 50 x Ø20
2.6 Grinding devices	
Single edge milling cutter	Up to Ø 12mm (Standard scope of delivery)
Turning tool	Up to 21mm x 21mm
Drill bit	Up to Ø 12mm
End mill cutter	Up to Ø 12mm (Standard scope of delivery)
2.7 Collet seat	
385E (5C) , DIN 6341	385E (5C) , DIN 6341 G = 26.45 x 1/24" d = 31.75 D = 37.5 L = 89 20°
	
2.8 Dimensions	
Height [mm]	340
Depth [mm]	450
Width [mm]	350
Net weight [kg]	50
2.9 Environmental conditions	
Temperature	5-35 °C
Humidity	25 - 80%

2.10 Emissions

The generation of noise (emission) emitted by the grinding machine for burins is 72 dB(A).
If the grinding machine for burins is installed in an area where various machines are in operation, the noise exposure (immission) on the operator of the grinding machine for burins at the working place may exceed 80 dB(A).



INFORMATION

This numerical value was measured on a new machine under proper operating conditions. Depending on the age respectively on the wear of the machine it is possible that the noise behaviour of the machine changes.

Furthermore, the factor of the noise emission is also depending on manufacturing influencing factors, e.g. speed, material and clamping conditions.



INFORMATION

The mentioned numerical value is the emission level and not necessarily a safe working level.

Though there is a dependency between the degree of the noise emission and the degree of the noise disturbance it is not possible to use it reliably to determine if further precaution measures are required or not.

The following factors influence the actual degree of the noise exposure of the operator:

- Characteristics of the working area, e.g. size or damping behaviour,
- Other noise sources, e.g. the number of machines,
- Other processes taking place in the proximity and the period of time during which the operator is exposed to the noise.

Furthermore, it is possible that the admissible exposure level might be different from country to country due to national regulations.

This information about the noise emission shall allow the operator of the machine to more easily evaluate the endangering and risks.



CAUTION!

Depending on the overall noise exposure and the basic limit values the machine operators has to wear an appropriate hearing protection.

We generally recommend to use a noise protection and a hearing protection.



2.11 Dimensions cup wheel

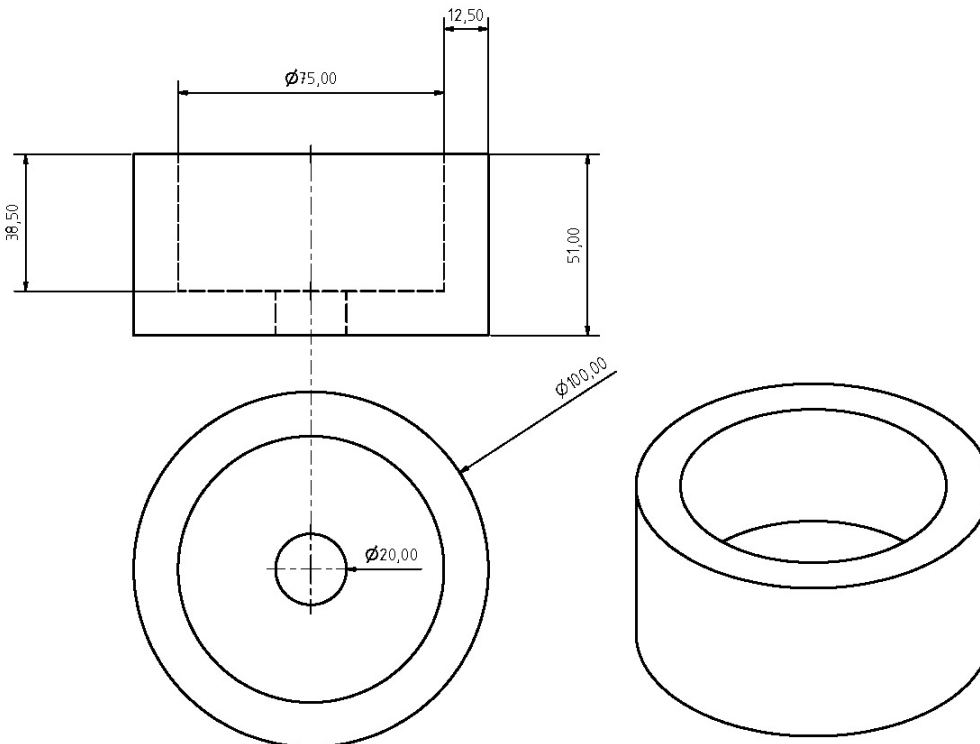



3 Assembly

3.1 Scope of delivery

When the machine is delivered, check immediately that the machine has not been damaged during transport and that all components are included. To do so take all parts out of the packaging and compare the parts with the figure below to be able to assign the individual parts.

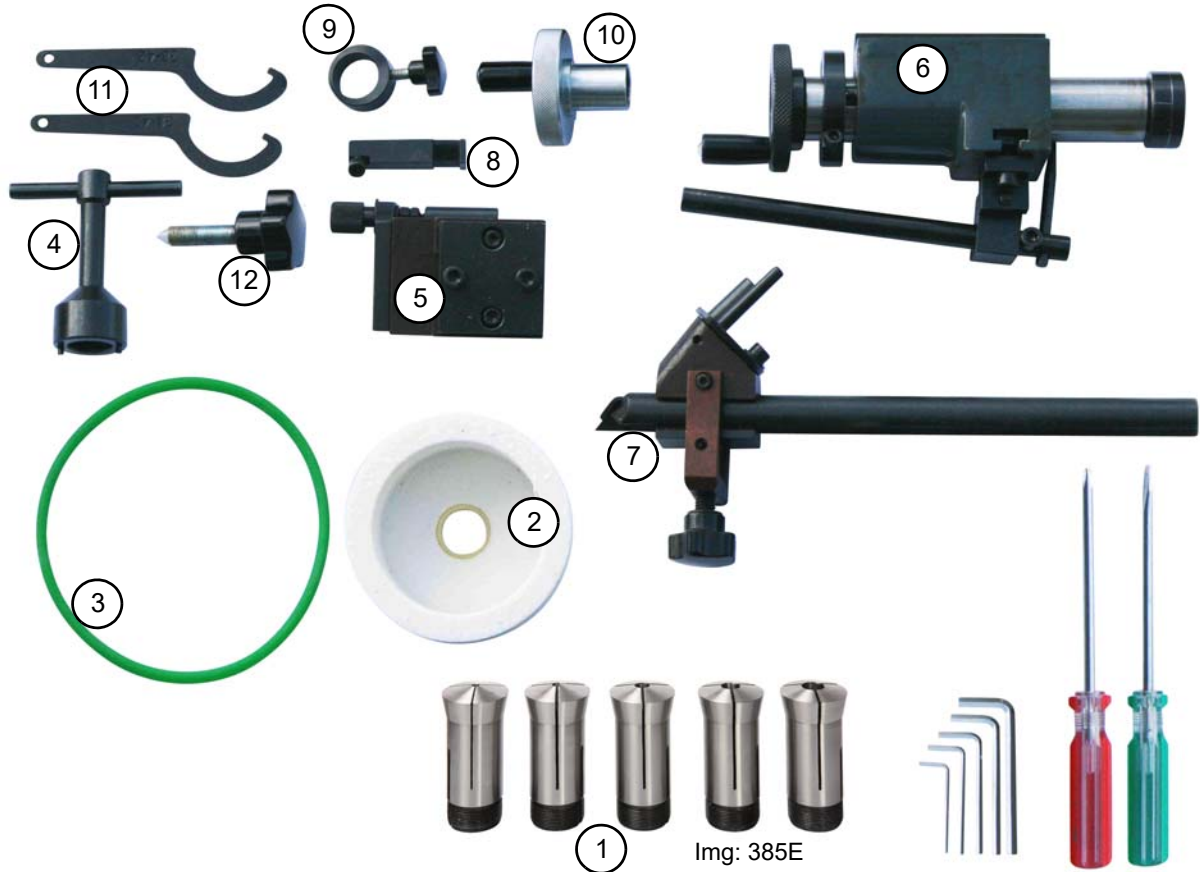

Img.3-1: Accessories

Figure No	Quantity	Description
1	5	Collets type 385E D=28 , L = 89 ; 20° DIN 6341 Size 4mm ; 6mm ; 8mm ; 10mm ; 12mm collets delivered with older machine models Collets type 355E D=28 , L = 123 ; 35° DIN 6341 Size 4mm ; 6mm ; 8mm ; 10mm ; 12mm
2	1	Corundum cup wheel Ø100 x 50 x Ø20 Diamond cup wheel Ø100 x 50 x Ø20 (mounted on the machine when delivered)
3	1	Spare round belt
4	1	Socket to mount the cup wheels
5	1	Device to regrind turning tools
6	1	Device to regrind end mills
7	1	Device to regrind twist drills
8	1	Clamping ring for the device twist drill
9	1	Clamping piece for the device twist drill
10	1	Crank to clamp the tool collet chuck
11	2	Hook wrench size 38 - 42 to reclamp the collet chuck seat

GH20T_GB_3_fm



3.2 Storage

ATTENTION!

In case of wrong and improper storage electrical and mechanical machine components might get damaged and destroyed.

Store packed and unpacked parts only under the intended environmental conditions.

Follow the instructions and information on the transport case.



- Fragile goods
(Goods require careful handling)



- Protect against moisture and humid environment
- ☞ Environmental conditions on page 13



- Prescribed position of the packing case
(Marking of the top surface - arrows pointing to the top)



- Maximum stacking height

Example: not stackable - do not stack a second packing case on top of the first one.



Consult Optimum Maschinen Germany GmbH if the machine and accessories are stored for more than three months or are stored under different environmental conditions than those given here. ☞ Information on page 5



3.3 Installation and assembly

3.3.1 Requirements regarding the installation site

INFORMATION

In order to attain good functionality and a high processing accuracy as well as a long durability of the machine the installation site should fulfil certain criteria.



Please observe the following points:

- The device must only be installed and operated in a dry and well-ventilated place.
- Avoid places nearby machines generating chips or dust.
- The installation site must be free from vibrations also at a distance of presses, planing machines, etc.
- Any parts sticking out such as stops, handles, etc. have to be secured by measures taken by the customer if necessary in order to avoid endangerment of persons.
- Provide sufficient space for the staff preparing and operating the machine and transporting the material.
- Also consider that the machine is accessible for setting and maintenance works.

Provide for sufficient illumination (Minimum value at the working place: 300 lux).
If the illuminance is too little make sure to provide additional illumination.

INFORMATION

The mains plug of the grinding machine for burins must be freely accessible.



3.3.2 Electrical connection

- ➔  Qualification of personnel on page 8
- ➔ Connect a CEE-400V-16A plug. We recommend you to use a CEE-400V-16A plug with pole switch since the rotating field might change when you connect the machine to another outlet.
- ➔ Make sure to switch to the correct rotation direction. The rotation direction arrow is found on the protective cover of the cup wheel.

3.3.3 Assembly

- ➔ Turn the handwheel for the shaft shoulder into the seat thread.

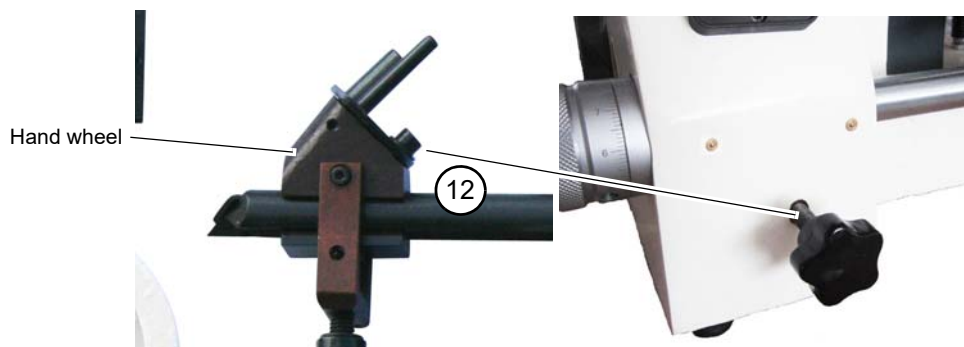

Img.3-2: Handwheel shaft shoulder



→ Plug the clamping piece and the clamping ring on the device.

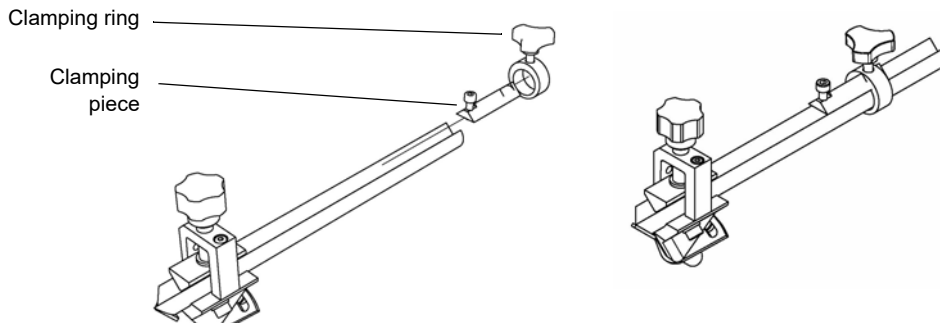

Img.3-3: Device drill bit

3.4 First commissioning

ATTENTION!

Before commissioning the machine check all screws, fixtures and the clamping lever and tighten up the screws if necessary!



CAUTION!

The cup wheel might get damaged during transportation.

Let the grinding machine for burins and tools run in for about 15 minutes before you start grinding.



☞ Personal protective equipment for special works on page 11.



4 Operation

This grinding machine is generally designed to grind a single edge milling cutters (burins) but it is also suitable to manufacture stamps, electrodes or round grinding parts and for regrinding of end mills on the face and on the diameter. With the workpiece holders available as accessories, blanks, cutters and drills can be ground.

By means of the versatile slewing and setting options all requirements are covered in order to grind a graver with any cutter shape (e.g. cylindrical, conical, centric and eccentric radii). Furthermore it is possible to create polygons (3- to 24- edge) on stamps and electrodes.

Unfortunately is a complete description of the manifold setting and regrinding options not possible. The possibilities with the grinding machine can be seen in a video.
<https://www.youtube.com/user/OptimumMaschinen>

4.1 Safety

Operate the grinding machine for burins only under the following conditions:

- The grinding machine for burins is in proper working order.
- The grinding machine for burins is used as intended.
- Follow the operating instructions.
- All safety devices are installed and activated.

All failures should be eliminated immediately. Stop the grinding machine for burins immediately in the event of any failure in operation and make sure that the grinding machine for burins can not be started up accidentally or without authorization.

Notify the person responsible immediately of any modification.

Safety during operation on page 11



Img.4-1: Grinding machine for burins and tools

GH20T_GB_4_fm

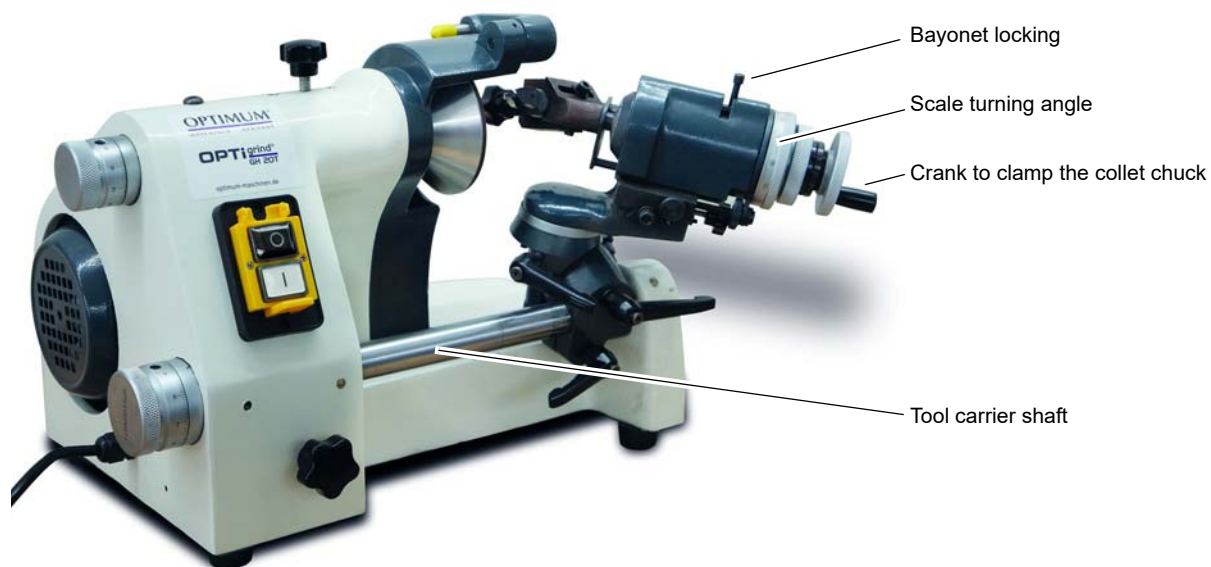



4.2 Assembly and function

- The driving pulley (14) seated on the motor is driven by a round belt (3) the pulley (19) and the spindle.
- Switch (Emergency-Stop switch) (15) to switch the machine on and off.
- Handwheel (17) for axial adjustment of the shaft for the tool holder (16).
- Handwheel (12) to set the stop of the shaft by means of the tool holder (16).
- Use the clamping lever (18) in order to clamp the shaft of the tool carrier (16).
- Handwheel (12) for fine setting of the cup wheel (2) by means of the clamping screw (21).
- Dressing diamond (24) to dress the cup wheel (2).

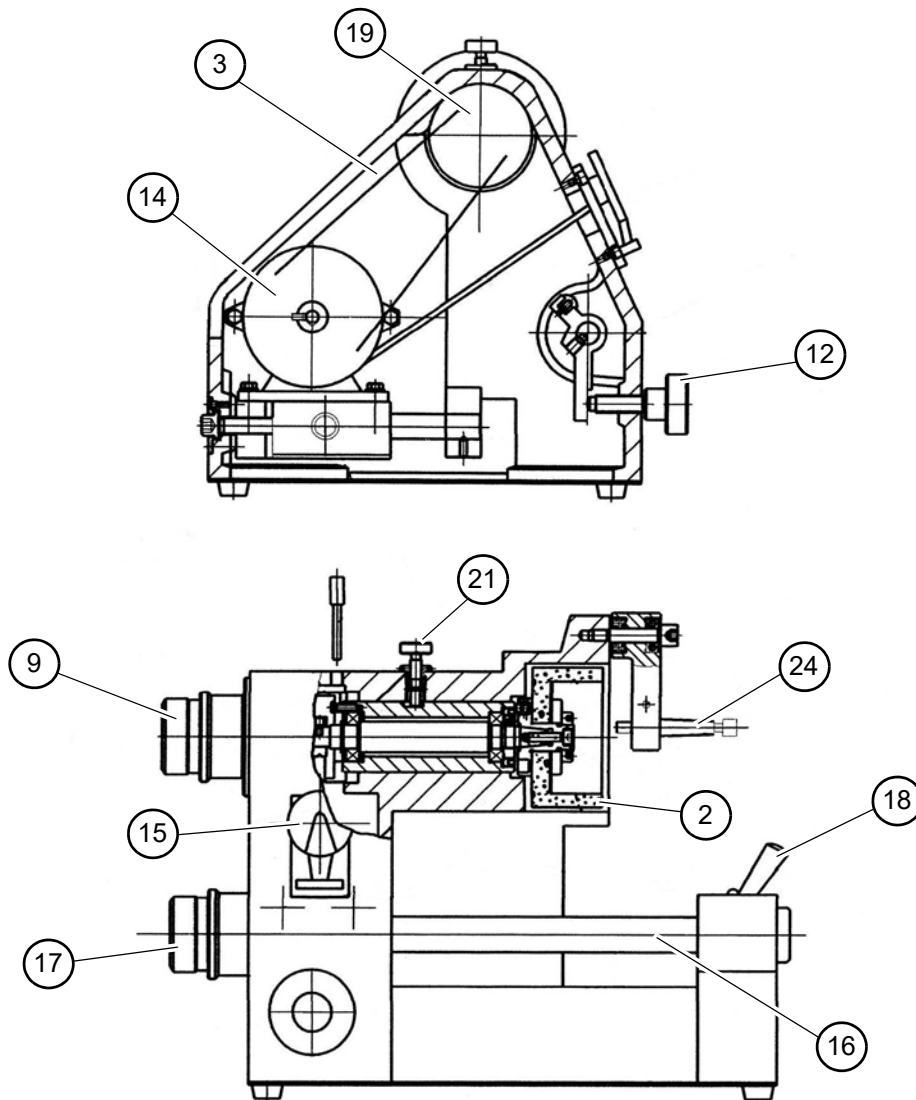

Img.4-2: Grinding machine for burins and tools



4.3 Handling the tool holder

The tool which needs to be machined is clamped in the collet chucks (30). The collet chucks are tightened by means of the crank (31).

The fine adjustment of the bushing (32) which is located in the collet chuck (30) is performed in axial direction using the knurled screw (33) on the carriage.

The division of the scale disc (34) is performed in steps of 15°. The bolt (35) which fixes the scale disc (34) is held by means of the bayonet locking (36). The scale disc (34) can be freely moved when the bayonet locking (36) is cammed in. It is possible to adjust the upper part of the support by means of the screw (37). Read the values from the scale (38) and from the vernier (39) for exact setting.

If both values of the scale (38) with (39) are set to 0 the grinding machine for burins is in the basic setting.

In order to turn the slewing arm (40) at an angle of up to 90° it is necessary to release the clamping lever (41).

It is possible to tilt the slewing arm (40) at an angle of up to 40° by means of an clamping lever (42). It is necessary to tighten the lever (43) in order to fix the tool holder on the shaft. The clamping lever (44) fixes the shaft.

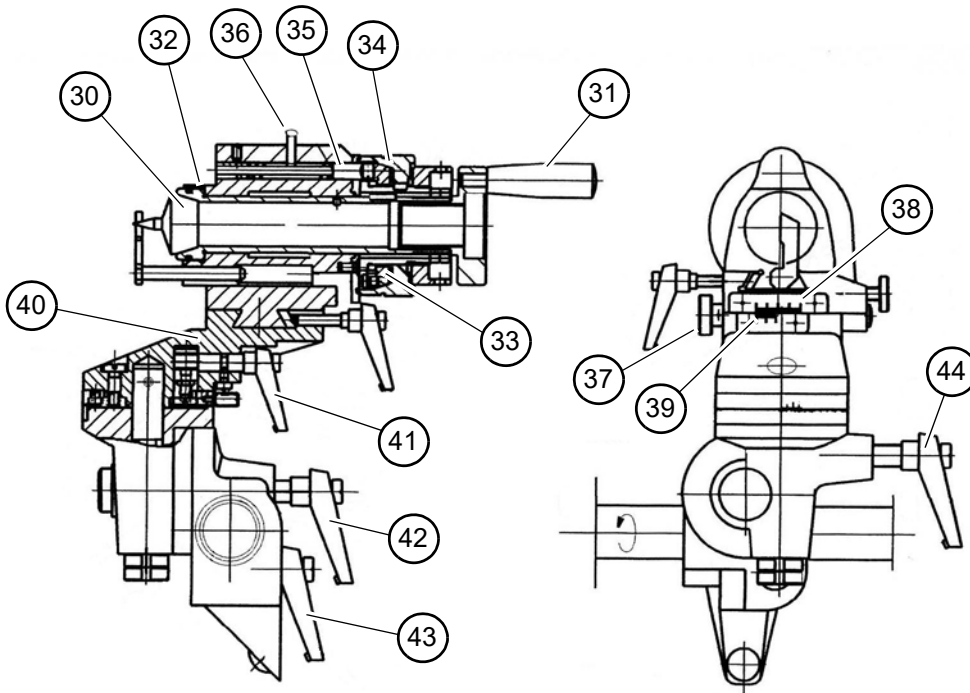

Img.4-3: Tool holder



4.4 Setting the shaft shoulder

Clamp the tool in the collet chuck (30) and release the lever (18) in order to be able to move the shaft (16).

The stop of the shaft (16) is set for the tool carrier by means of the handwheel (12). If the handwheel (12) is turned in the possible rotation movement of the shaft to the stop is being reduced. Clamp the clamping lever (44) in order to control the rotation movement.

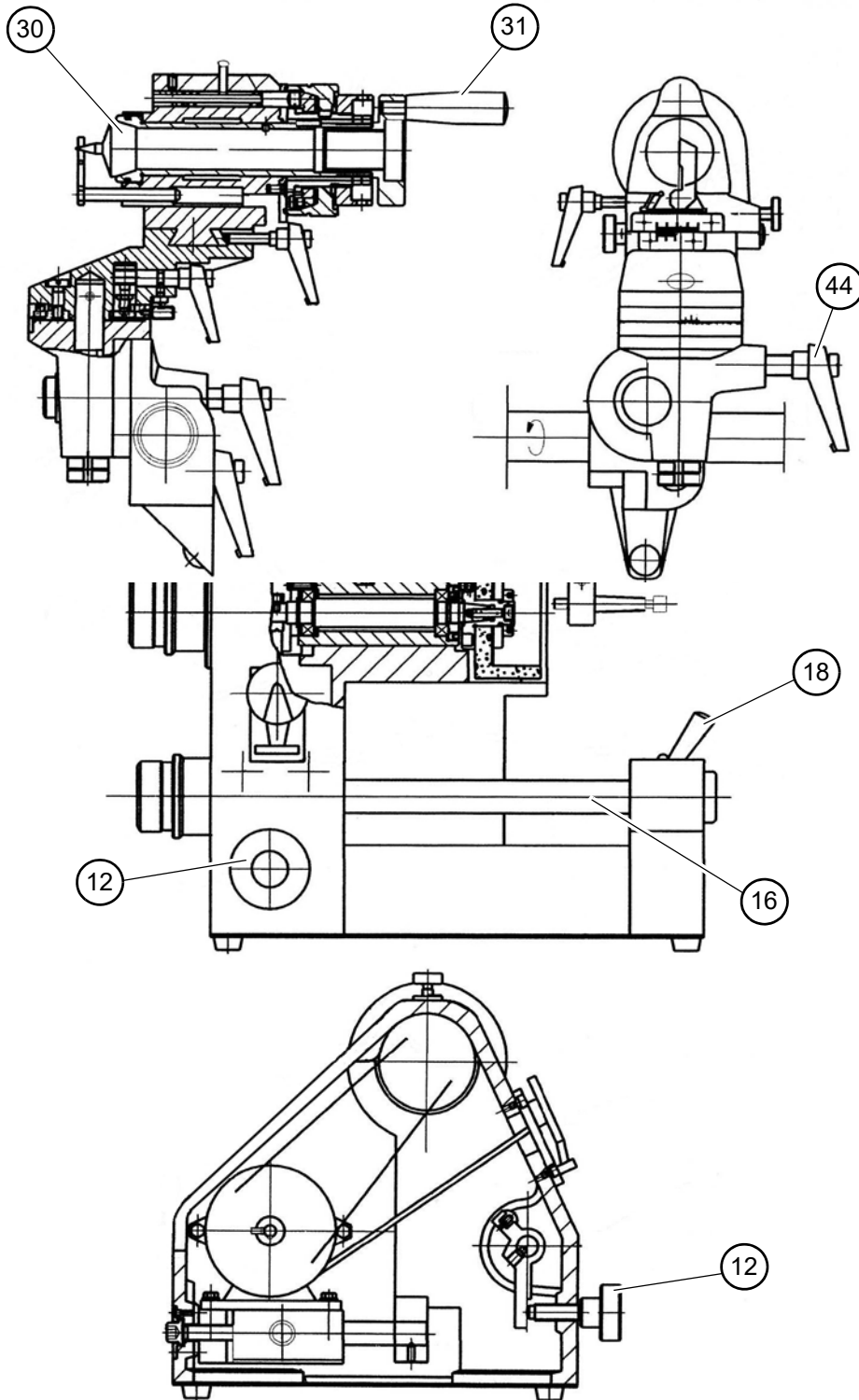



4.5 Grinding angles

Set the upper part of the support by means of the scale (38) and the vernier (39). Both values must be set to 0.

Release the clamping lever (42) and then tilt the slewing arm (40) at an angle of 0 degree. Then, release the clamping lever (18) in order to be able to move the shaft.

Set the slewing arm (40) to the desired angle by releasing the lever (44). Turn the handwheel (12) in order to set the stop.

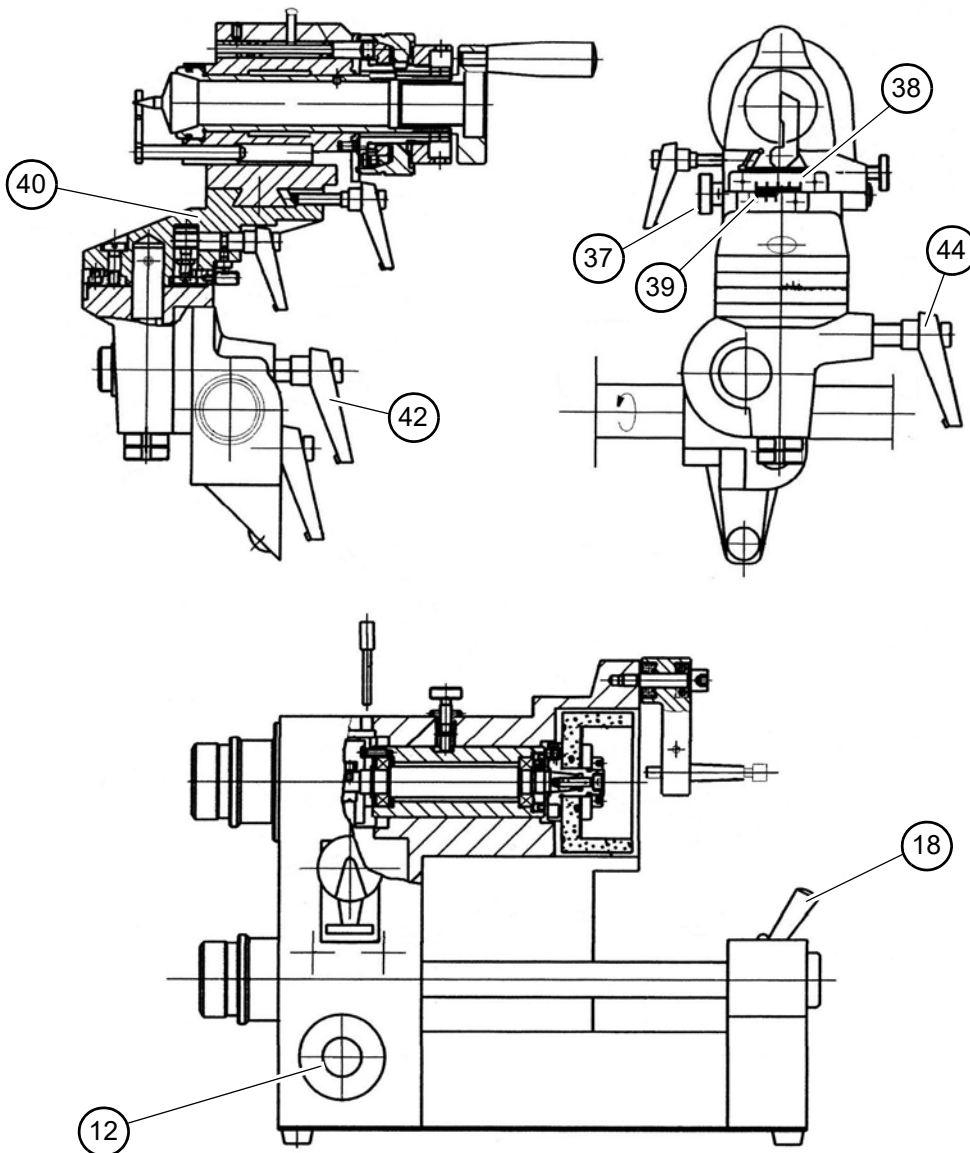



4.6 Assembling the devices

4.6.1 Grinding device for drill bit

On the grinding device for the drill bit it is not necessary to disassemble the already existing grinding device for the single edge milling cutter (burin).

Pull the stop (48) out of the bushing and introduce (49). (50) is fixed in the collect chuck (30).

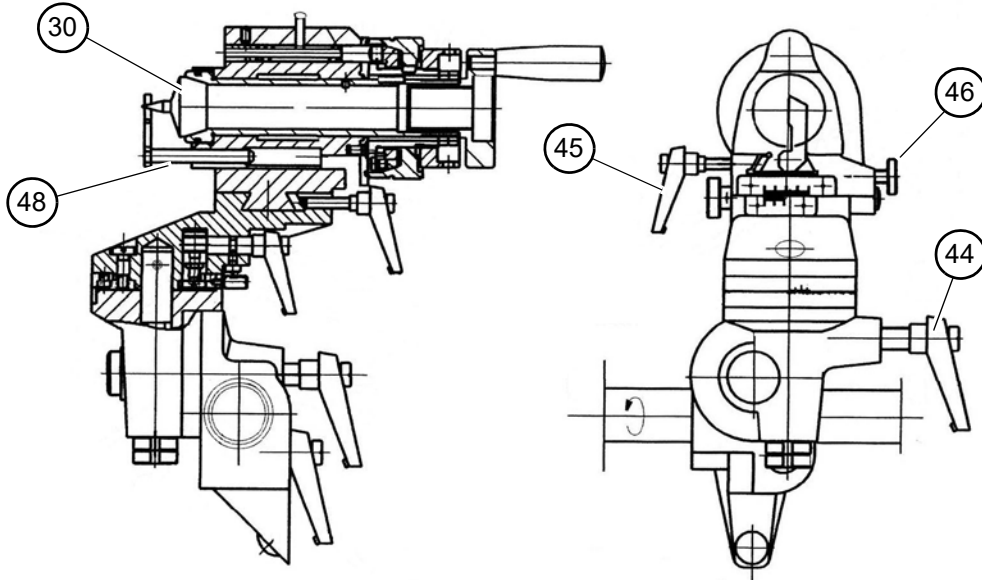

Img.4-4: Device single edge milling cutter

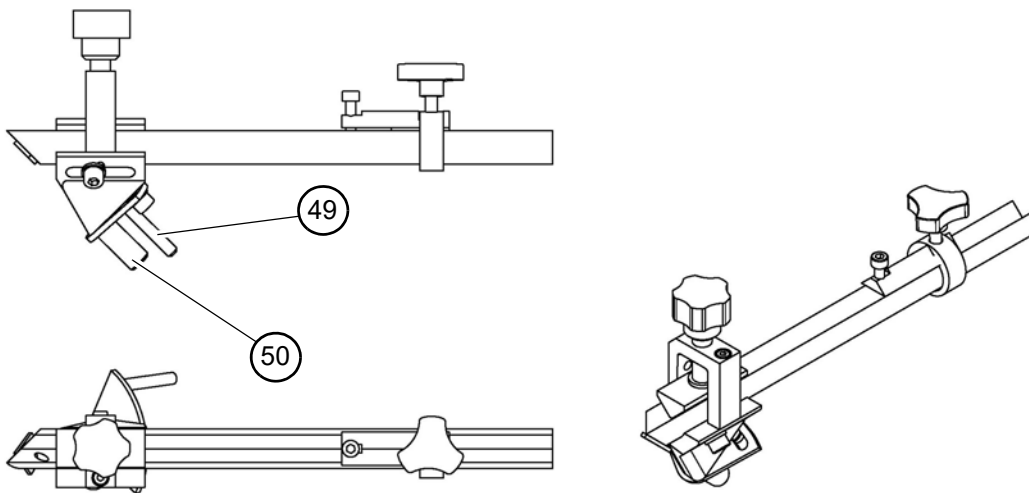

Img.4-5: Device twist drill



4.6.2 Grinding device turning tool

In order to assemble the grinding device for milling cutters and turning tools it is necessary to disassemble the grinding device for single edge milling cutters.

To remove the mounted grinding device for single edge milling cutters (burin):

- ➔ Release the clamping lever (45) and the knurled screw (46).
- ➔ Pull the grinding device over the dovetail guide.

Make sure that the V-ledge does not fall down. If required reset the V-ledge for the devices.

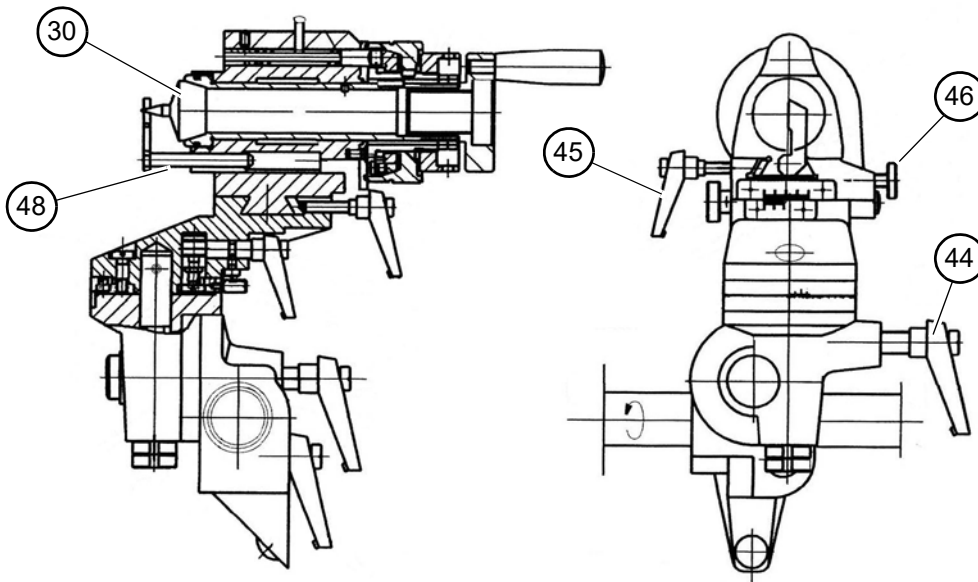

Img.4-6: Device single edge milling cutter

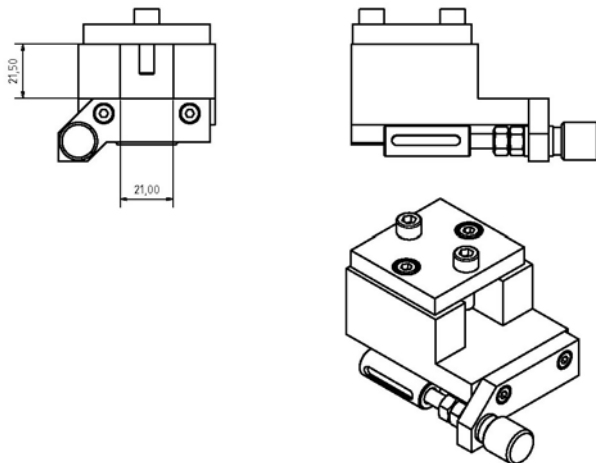

Img.4-7: Device HSS turning tool



4.6.3 Grinding device end mill

In order to assemble the grinding device for milling cutters and turning tools it is necessary to disassemble the grinding device for single edge milling cutters.

To remove the mounted grinding device for single edge milling cutters (burin):

- ➔ Release the clamping lever (45) and the knurled screw (46).
- ➔ Pull the grinding device over the dovetail guide.

Make sure that the V-ledge does not fall down. If required reset the V-ledge for the devices.

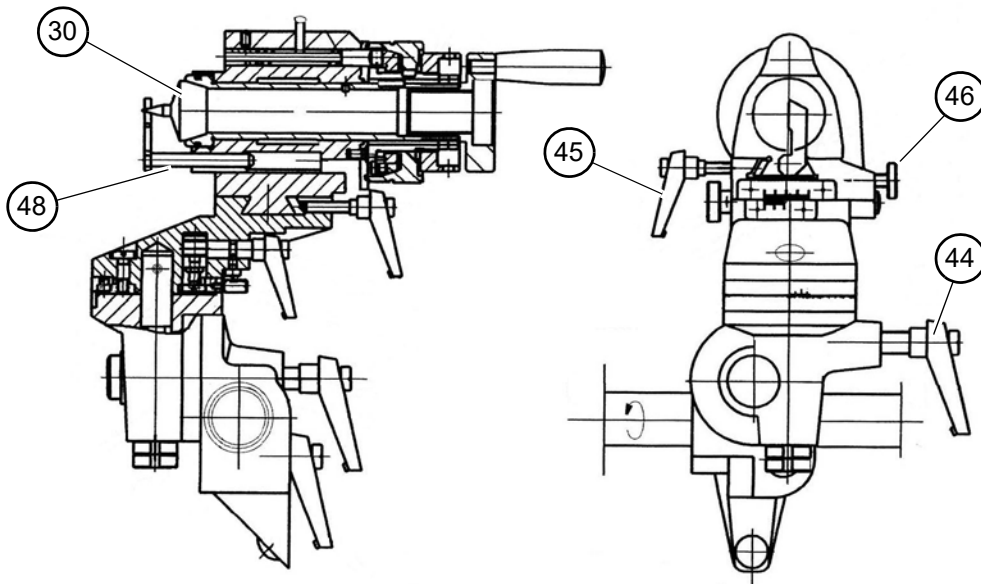

Img.4-8: Device single edge milling cutter

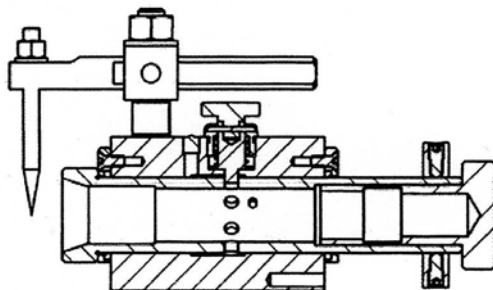

Img.4-9: Device end mill



5 Maintenance

In this chapter you will find important information about

- Inspection
- Maintenance
- Repair

of the grinding machine for burins and tools.

ATTENTION !

Properly performed regular maintenance is an essential prerequisite for

- operational safety,
- failure-free operation,
- long service life of the grinding machine for burins and
- the quality of the products to be manufactured.

Installations and equipment from other manufacturers must also be in good order and condition.



5.1 Safety

WARNING!

The consequences of incorrect maintenance and repair work may include:

- Heaviest injuries of the persons working on the grinding machine for burins and tools
- Damages to the grinding machine for burins

Only qualified staff should carry out maintenance and repair work on the grinding machine for burins and tools.



5.1.1 Preparation

WARNING!

Only carry out work on the grinding machine for burins and tools if it has been switched off using the mains plug.



5.1.2 Restarting

WARNING!

Before starting the grinding machine for burins, make sure that there exists

- no dangers generated for persons,
- no damage to the grinding machine for burins and tools.





5.2 Inspection and maintenance

The type and extent of wear depends to a large extent on individual usage and service conditions.

- Regularly clean the grinding machine for burins from grinding dust. Soiling by grinding dust in the slideways leads to relevant wear. If necessary - use compressed air to clean the grinding machine for burins from grinding dust.
- If you recognize much positive allowance of the slideways, fasten the adjustment screws accordingly.
- Lubricate the lubricating nipples in regular intervals.

5.2.1 Exchange of the abrasive wheel

WARNING!

Check if the cup wheels are damaged or have cracks before mounting them.

If a new cup wheel is damaged or shows cracks it must not be mounted in any way.

Disconnect the power cable from the power supply before removing the disc!

- Loosen the screw at the top of the machine with the Allen wrench and unscrew it.
- Insert a screwdriver into the hole, turn the washer to find the locking hole in the shaft so that the screwdriver snaps into place.
- Using the supplied wrench, loosen the disc clamping nut, remove the flange, rubber disc and grinding disc.
- There is little space between the disc and the shaft, do not use excessive force or tools to remove the disc.
- When installing, proceed in reverse order and do not forget to screw the screw into the hole so that no grinding dust gets to the shaft.





5.3 Repair

5.3.1 Customer service technician

For any repair work request the assistance of an authorised customer service technician. Contact your specialist dealer if you do not have customer service's information or contact Stürmer Maschinen GmbH in Germany who can provide you with a specialist dealer's contact information. Optionally, the

Stürmer Maschinen GmbH

Dr.-Robert-Pfleger-Str. 26

D- 96103 Hallstadt

can provide a customer service technician, however, the request for a customer service technician can only be made via your specialist dealer.

If the repairs are carried out by qualified technical personnel, they must follow the indications given in these operating instructions.

Optimum Maschinen Germany GmbH accepts no liability nor does it guarantee against damage and operating malfunctions resulting from failure to observe these operating instructions.

For repairs only use

- faultless and suitable tools,
- original parts or parts from series expressly authorised by Optimum Maschinen Germany GmbH.

6 Ersatzteile - Spare parts

6.1 Ersatzteilbestellung - Ordering spare parts

Bitte geben Sie folgendes an - Please indicate the following :

- Seriennummer - Serial No.
- Maschinenbezeichnung - Machines name
- Herstellungsdatum - Date of manufacture
- Artikelnummer - Article no.

Die Artikelnummer befindet sich in der Ersatzteilliste. *The article no. is located in the spare parts list.* Die Seriennummer befindet sich am Typschild. *The serial no. is on the rating plate.*

6.2 Hotline Ersatzteile - Spare parts Hotline



+49 (0) 951-96555 -118
ersatzteile@stuermer-maschinen.de



6.3 Service Hotline



+49 (0) 951-96555 -100
service@stuermer-maschinen.de



6.4 Ersatzteilzeichnungen - Spare part drawings

A GH20T

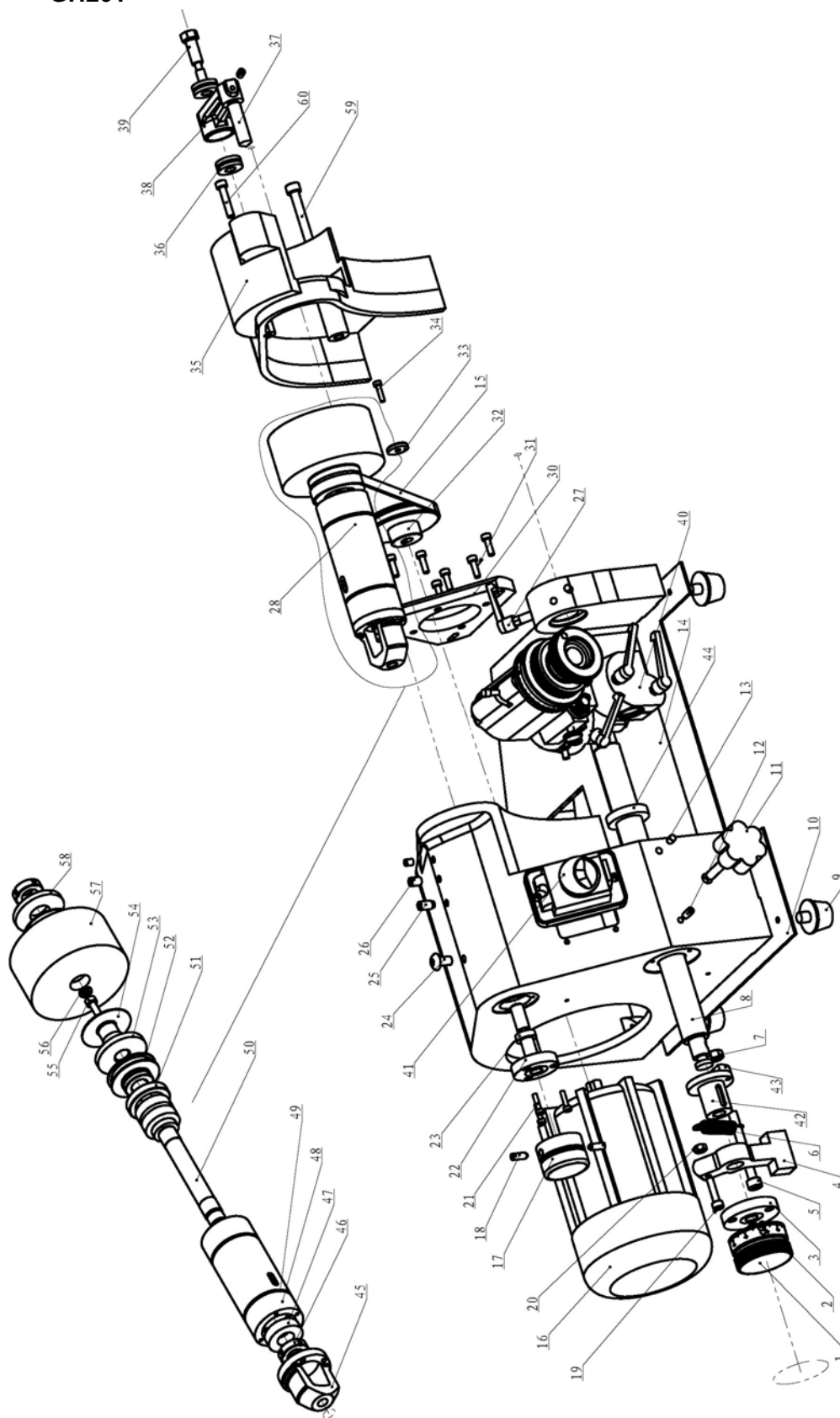

Img. 6-1: Ersatzteilzeichnung - Drawing spare parts GH20T

Pos.	Bezeichnung	Description	Menge Qty.	Grösse Size	Artikelnummer	
					Item no.	
					G20T	GH20TB
1	Handrad mit Skala	Hand scale wheel	1		0310012501	
2	Schraube	Screw	3	M6x12		
3	Skalenring	Lower indicatina dial	1		0310012103	
4	Halter	Holder	1		0310012104	
5	Schraube	Screw	2	M8X70		
6	Feder	Spring	1			
7	Sechskantmutter	Hexagon nut	1	M8		
8	Welle	Shaft	1		0310012108	
9	Maschinenfuß	Machine foot	4		0310012109	
10	Abdeckung	Cover	1			
11	Handrad	Handle	1	M12X55	0310012111	
12	Gewindestift	Grub screw	1			
13	Schmiernippel	Oil cup	4	6	0340105	
14	Unterbau	Base	1		0310012114	
15	Riemen	Belt	1		0310012503	
16	Motor	Motor	1		0310012516	0310012116
16K	Kondensator	Capacitor	1			0310012116K
17	Handrad mit Skala	Graduation hand wheel	1		0310012517	
18	Schraube	Screw	2	M6X16		
19	Schraube	Screw	2	M6X25		
20	Schraube	Screw	3	M6		
21	Schraube	Screw	4	M4		
22	Skalenring	Upper indicating dial	1		0310012122	
23	Ring	Ring	1			
24	Schraube	Screw	1	M8X15		
25	Gewindestift	Grub screw	1			
26	Schraube	Screw	1	M6X3		
27	Handhebel	Locking handle	1	M8X25	0310012127	
28	Antrieb	Grinding unit assembly	1		0310012128	0310012528
29	Arbeitsleuchte	Working lamp	1		0310012529	
29SB	LED Lampe	LED Lamp	1		0310012529SB	
30	Motorflansch	Motor flange	1		0310012130	
31	Schraube	Screw	7	M5X16		
32	Riemenscheibe	Subordinate driving wheel	1		0310012132	
33	Scheibe	Thick gasket	1			
34	Schraube	Screw	1	M4X14		
35	Abdeckung	Cover	1			
36	Axiallager	Thrust ball bearing	2	51100	04051100	
37	Stift	Pin	1		0310012537	
38	Halter	Holder	1		0310012138	
39	Klemmschraube	Finisher fixing screw	1			
40	Klemmvorrichtung	Universal clamp holder	1		0310012540	
41	Ein-Aus-Schalter	Electromagnetic switch	1		0310012541	031001210052
42	Abdeckung	Nut cover	1		0310012142	
43	Platte	Driving gasket	1		0310012143	
44	Dichtung	Grease seal	1			
45	Antriebskopf	Driving head	1		0310012145	
46	Klemmmutter	Locking round nut	2			
47	Kugellager	Bearing	3			
48	Abdeckung	Spindle cover	1		0310012148	
49	Ring	Sealing ring	1			
50	Welle	Shaft	2		0310012150	
51	Ring	Ring	1			
52	Ring	Ring	1			
53	Scheibe	Washer	1		0310012553	
54	Flansch	Flange	1		0310012154	
55	Dichtung	Asbestos gasket	2			
56	Schraube	Screw	1	M6X25		
57	Dichtung	Gasket	1	8		
58	Riemenscheibe	Grinding wheel	1		0310012558	
59	Flansch	Flange	1		0310012159	
60	Schraube	Screw	1			
61	Schraube	Screw	1	M8X60		
62	Schraube	Screw	1	M6X30		
CPL	Werkzeughalter A Drehmeißel	Tool holder A			03100125A	
CPL	Werkzeughalter B Fräser	Tool holder B			03100125B	
CPL	Werkzeughalter C Spiralbohrer	Tool holder C			03100125C	
2-1	Diamant-Topfschleifscheibe Ø100 x 50 x Ø20	Corundum cup wheel Ø100 x 50 x Ø20			3100129	

GH20T_parts.fm

B Zubehör - Accessories GH20T

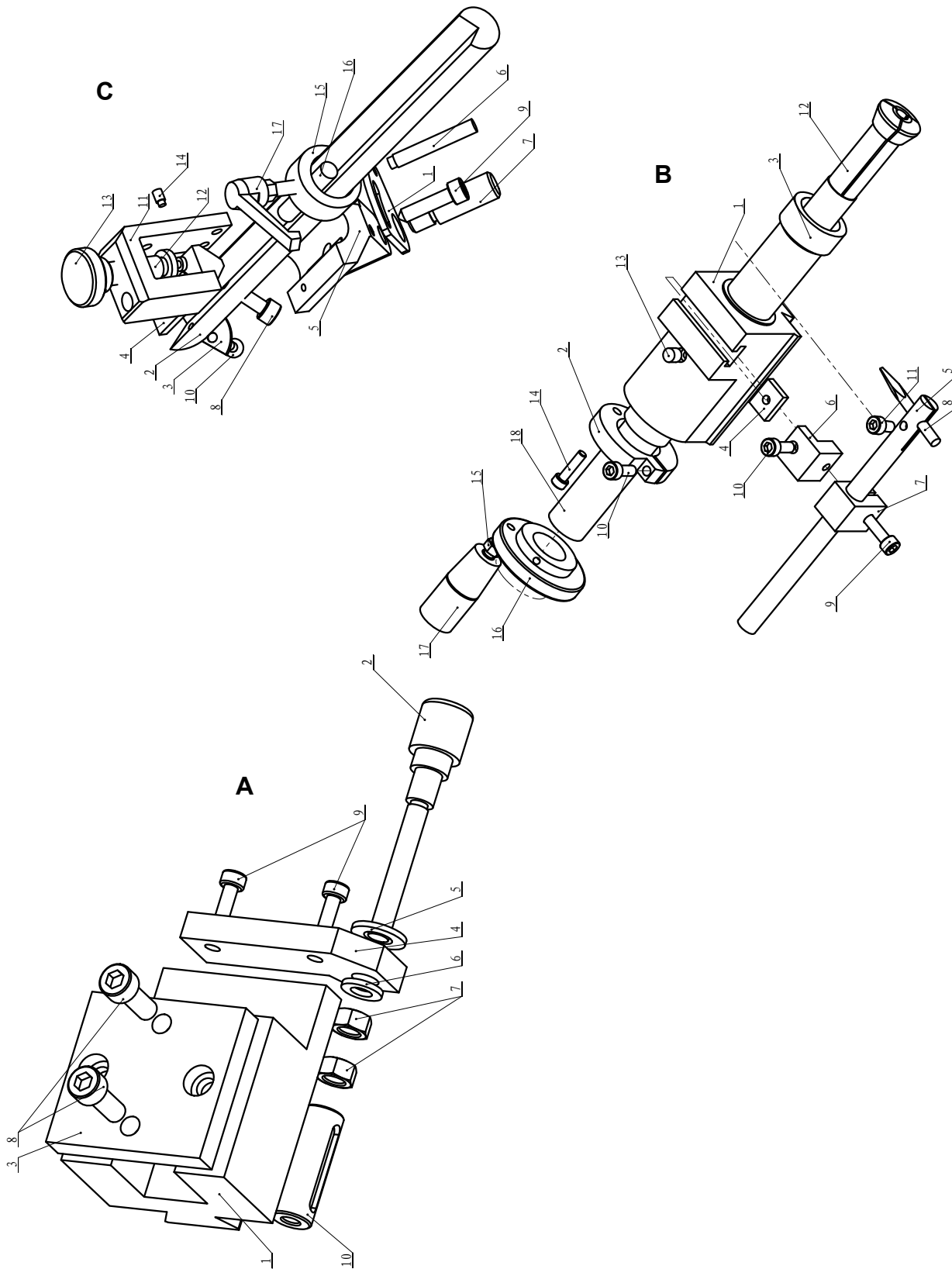

Img. 6-2: Zubehör - Accessories GH20T

Vorrichtung A - Fixture A						
Pos.	Bezeichnung	Description	Menge Qty.	Grösse Size	Artikelnummer	
					Item no.	
					G20T	GH20TB
1	Werkzeughalter	Tool holder	1		03100121101	03100125101
2	Einstellschraube	Screw Dole	1		03100121102	03100125102
3	Platte	Pressure plate	1		03100121103	03100125103
4	Lagerbock	Fixed plate	1		03100121104	03100125104
5	Scheibe	Flat washer	1		03100121105	03100125105
6	Scheibe	Flat washer	1		03100121106	03100125106
7	Sechskantmutter	Hexagon nut	2		03100121107	03100125107
8	Schraube	Screw	2	M6X16	03100121108	03100125108
9	Schraube	Screw	3	M4X10	03100121109	03100125109
10	Hülse	Guide sleeve	1		03100121110	03100125110

Vorrichtung B - Fixture B						
Pos.	Bezeichnung	Description	Menge Qty.	Grösse Size	Artikelnummer	
					Item no.	
					G20T	GH20TB
1	Halter	Slide bracket	1		03100121201	03100125201
2	Halterung	Fastning set	1		03100121202	03100125202
3	Hülse	Telescopic cylinder	1		03100121203	03100125203
4	Platte	Stator	1		03100121204	03100125204
5	Stange	Locate strut	1		03100121205	03100125205
6	Block	Fixed block	1		03100121206	03100125206
7	Halter	Fastning block	1		03100121207	03100125207
8	Stift	Guide pole	1		03100121208	03100125208
9	Schraube	Screw	4	M6X25	03100121209	03100125209
10	Schraube	Screw	4	M6X16	03100121210	03100125210
11	Schraube	Screw	4	M6X10	03100121211	03100125211
12	Spannzange	Knife grinder chuck	1		03100121212	03100125212
13	Ölnippel	Oil cup	1		03100121213	03100125213
14	Schraube	Screw	1	M5X20	03100121214	03100125214
15	Sechskantmutter	Hexagonal nun	1	M5	03100121215	03100125215
16	Handrad	Handle	1		03100121216	03100125216
17	Griff	Grip	1		03100121217	03100125217
18	Welle	Shaft	1		03100121218	03100125218

Vorrichtung C - Fixture C						
Pos.	Bezeichnung	Description	Menge Qty.	Grösse Size	Artikelnummer	
					Item no.	
					G20T	GH20TB
1	Führung	Guide plate	1		03100121301	03100125301
2	Stange	Clamping rod	1		03100121302	03100125302
3	Block	Knife block	1		03100121303	03100125303
4	Klemmplatte	Clamping block	1		03100121304	03100125304
5	Halter	Locate block	1		03100121305	03100125305
6	Welle	Fixed shaft	1		03100121306	03100125306
7	Welle	Shaft	1		03100121307	03100125307
8	Schraube	Screw	1	M6X14	03100121308	03100125308
9	Schraube	Screw	1	M6X12	03100121309	03100125309
10	Schraube	Screw	1	M4X8	03100121310	03100125310
11	Halter	Fixed block	1		03100121311	03100125311
12	Klemmschraube	Lock screw	1		03100121312	03100125312
13	Handrad	Lock hander	1		03100121313	03100125313
14	Schraube	Limit-stop screw	1		03100121314	03100125314
15	Klemmring	Lock set	1		03100121315	03100125315
16	Stift	Locate strut	1		03100121316	03100125316
17	Klemmhebel	Klemmhebel	1	M6	03100121317	03100125317

6.5 Schaltplan - Wiring diagram

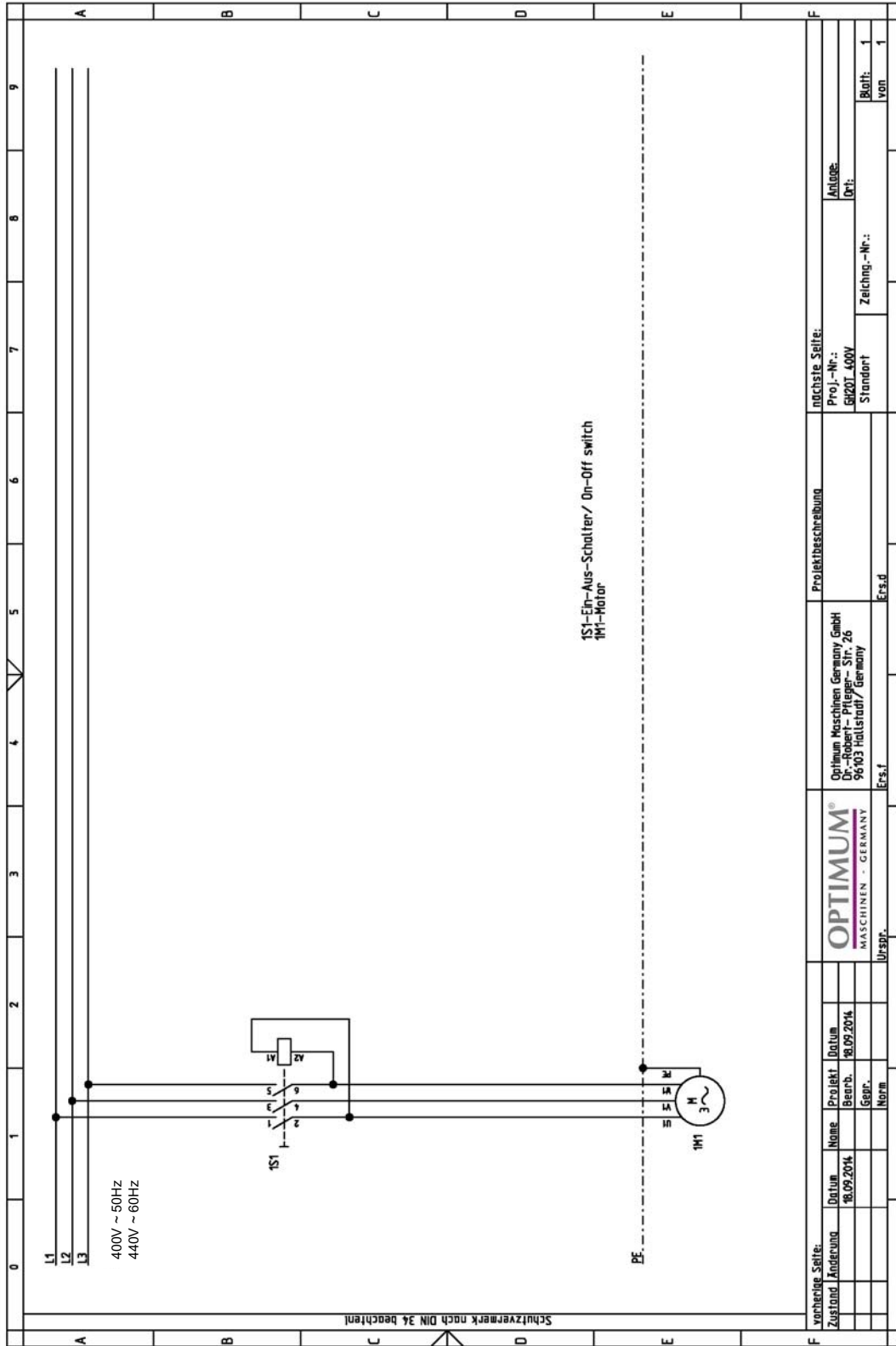



7 Annex

7.1 Copyright

This document is copyright. All derived rights are also reserved, especially those of translation, re-printing, use of figures, broadcast, reproduction by photo-mechanical or similar means and recording in data processing systems, neither partial nor total.

Subject to technical changes without notice.

7.2 Terminology/Glossary

Term	Explanation
Protective hood	Cover of the grinding disc and of the drive shaft.
Protective cover	Protective hood
Spark protection	Cover to protect against sparks when grinding.
Point angle	Angle of the complete tip of the drill bit
Clearance angle	Relief grinding on the drill bit
Relief angle	Clearance angle on the drill bit
Dead centre	Tip of the drill bit
Prism	Tool holder
Cutting edge	Cutting line of the drill bit

7.3 Change information manual

Chapter	Short note	new version no.
2	Type of collet from 5C to 355E S20X2 d=20	1.0.1
all	Manual expanded with 230V machine type	1.0.1
all	Manual expanded with machine type GH 20TB	1.0.2
3.1	Note, delivery GH 20T without machine lighting, circuit diagram 400V updated	1.0.3
7	Spare parts	1.0.4
2 + 6 + CE	Machine type GH20 TB removed from manual Update of CE declaration	1.0.5
2	Update for ~ 60Hz connection	1.0.6
5	Changing the grinding wheel	1.0.7
CE ; 3.1	update of CE declaration ; Scope of delivery	1.0.8
1.9.1 ; CE	Emergency stop removed ; CE updated	1.0.9



7.4 Product follow-up

We have a follow-up service for our products which extends even after shipment. We would be grateful if you could send us the following information:

- Modified settings. Experiences with the grinding machine for burins and tools which could be important to other users. Recurring failures.

Optimum Maschinen Germany GmbH

Dr.-Robert-Pfleger-Str. 26

D-96103 Hallstadt

Telefax +49 (0) 951 - 96 555 - 888 | email: info@optimum-maschinen.de

7.5 Liability claims for defects / warranty

Beside the legal liability claims for defects of the customer towards the seller the manufacturer of the product, OPTIMUM GmbH, Robert-Pfleger-Straße 26, D-96103 Hallstadt, does not grant any further warranties unless they are listed below or had been promised in the frame of a individual contractual agreement.

- The processing of the liability claims or of the warranty is performed as chosen by OPTIMUM GmbH either directly or through one of its dealers.
Any defective products or components of such products will either be repaired or replaced by components which are free from defects. The property of replaced products or components passes on to OPTIMUM GmbH.
- The automatically generated original proof of purchase which shows the date of purchase, the type of machine and the serial number, if applicable, is the precondition in order to assert liability or warranty claims. If the original proof of purchase is not presented, we are not able to perform any services.
- Defects resulting from the following circumstances are excluded from liability and warranty claims:
 - Using the product beyond the technical options and proper use, in particular due to overstraining of the machine
 - Any defects arising by one's own fault due to faulty operations or if the operating manual is disregarded
 - Inattentive or incorrect handling and use of improper equipment
 - Non-authorized modifications and repairs
 - Insufficient installation and safeguarding of the machine
 - Disregarding the installation requirements and conditions of use
 - Atmospheric discharges, overvoltage and lightning strokes as well as chemical influences
- The following items are as well not subject to the liability or warranty claims:
 - Wearing parts and components which are subject to a standard wear as intended such as e.g. V-belts, ball bearings, illuminants, filters, sealings, etc.
 - Non reproducible software errors
- Any services which OPTIMUM GmbH or one of its servants performs in order to fulfil in the frame of an additional guarantee are neither an acceptance of the defects nor an acceptance of its obligation to compensate. Such services do neither delay nor interrupt the warranty period.
- Place of jurisdiction among traders is Bamberg.
- If one of the above mentioned agreements is totally or partially inefficient and/or null, it is considered as agreed what is closest to the will of the warrantor and which remains in the framework of the limits of liability and warranty which are predefined by this contract.

7.6 Advice for disposal / Options of re-use

Please dispose of your machine in an environmentally friendly way, not by disposing of the waste not in the environment, but by acting in a professional way.



Please do not throw away the packaging and the used machine later on, but dispose of your material according to the guidelines established by your municipality or by the responsible waste management company.

7.6.1 Decommissioning

CAUTION!

Used devices need to be decommissioned in a professional way in order to avoid later misuses and endangerment of the environment or persons



- **Disconnect the machine from the mains.**
- **Cut the connecting cable into two.**
- **Remove all operating materials from the used device which are harmful to the environment.**
- **If required, remove the batteries and accumulators.**
- **If required, disassemble the machine into easy-to-handle and usable components and parts.**
- **Supply the machine components and operating materials to the provided disposal routes.**

7.6.2 Disposal of the packaging of the new machine

All used packaging materials and packaging aids of the machine are recyclable and generally need to be transported to the material recycling.

The packaging wood can be supplied to the disposal or reuse.

It is possible to crush any packaging material made of cardboard and supply it to the waste paper collection.

The films are made of polyethylene (PE) and the upholstery parts are made of polystyrene (PS). It is possible to reuse these materials after reconditioning, if you supply them to the collection station or to the responsible waste management company.

Supply the packaging material only correctly sorted, so that it is possible to directly supply it to the reuse.

7.6.3 Disposal of the used machine

INFORMATION

Please take care in your interest and in the interest of the environment that all component parts of the machine are only disposed of in the intended and admitted way.

Please note that electrical devices include a number of reusable materials as well as components which are harmful to the environment. Please help that these components are disposed of separately and professionally. In case of doubt, please contact your municipal waste management company. If necessary contact a specialised waste disposal centre to get help for the disposal.



7.6.4 Disposal of electrical and electronic components

Please make sure that the electrical components are disposed of professionally and according to the legal regulations.

The machine is composed of electrical and electronic components and must not be disposed of as household waste. According to the European directive 2002/96/EC regarding electrical and electronic used devices and the implementation of national legislation used power tools and electrical machines need to be collected separately and supplied to an environmentally friendly recycling centre.

Being the machine operator, you should gather information regarding the authorised collection or disposal system which applies for your company.



Please make sure that batteries and/or accumulators are disposed of in a professional way and according to the legal regulations. Please throw empty accumulators only into the collection boxes of retail markets or municipal waste disposal companies.

7.7 Disposal via municipal collecting points

Disposal of used electrical and electronic components

Disposal of used electric and electronic devices (Applicable in the countries of the European Union and other European countries with a separate collecting system for such devices).

The sign on the product or on its packing indicates that the product must not be handled as common household waste, but that it needs to be delivered to a central collection point for recycling. Your contribution to the correct disposal of this product will protect the environment and the health of your fellow men. The environment and the health are endangered by incorrect disposal. Recycling of material will help to reduce the consumption of raw materials. Your District Office, the municipal waste collection station or the shop where you have bought the product will inform you about the recycling of this product.





EC - Declaration of Conformity

**The manufacturer/
distributor:** Optimum Maschinen Germany GmbH
Dr.-Robert-Pfleger-Str. 26
D - 96103 Hallstadt

hereby declares that the following product

Product designation: GH 20T

Type designation: Grinding machine for burins and tools

Grinding machine for burins and tools for craft and industrial plants which meets all the relevant provisions of the above mentioned Directive 2006/42/EC as well as the other directives applied (below) including their amendments in force at the time of declaration.

The following other EU Directives have been applied:

EMC Directive 2014/30/EC ; Restriction of the use of certain hazardous substances in electrical and electronic equipment 2015/863/EU

The safety objective meet the requirement of EC Directive 2006/42/EC.

The following harmonized standards were applied:

EN 62841-3-4 Electric motor-operated hand-held tools, transportable tools and lawn and garden machinery - Safety - Particular requirements for transportable bench grinders

EN 12413 Safety requirements for bonded abrasive products

EN 60204-12006/AC 2010 Safety of machinery - Electrical equipment of machines - Part 1: General requirements

EN ISO 13849 - Safety of machinery - Safety-related parts of control systems

EN 1037 Safety of machinery - Prevention of unexpected start-up

EN ISO 12100 Safety of machinery - General principles for design - Risk assessment and risk reduction

Responsible for documentation: Kilian Stürmer, phone: +49 (0) 951 - 96 555 - 800

Address: Dr.-Robert-Pfleger-Str. 26
D - 96103 Hallstadt

Kilian Stürmer
(CEO, General Manager)

Hallstadt, 2022-02-16

