

# DBS-22 Instruction

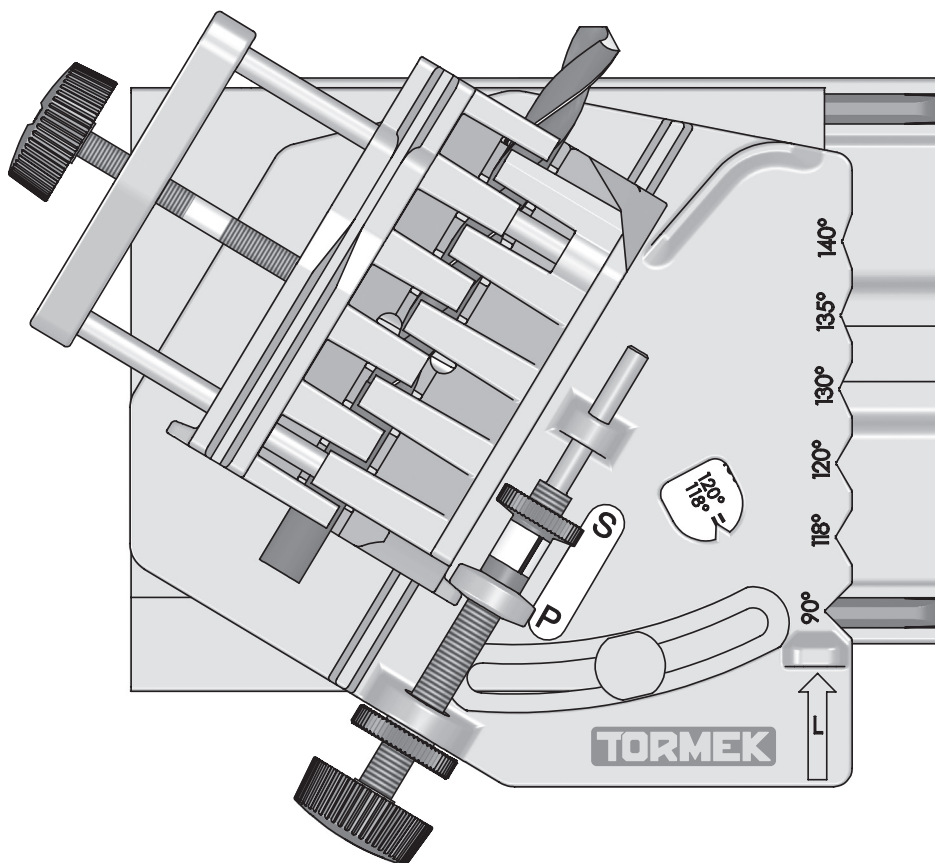

## PATENT

To see all patents visit  
[tormek.com/patents](http://tormek.com/patents)

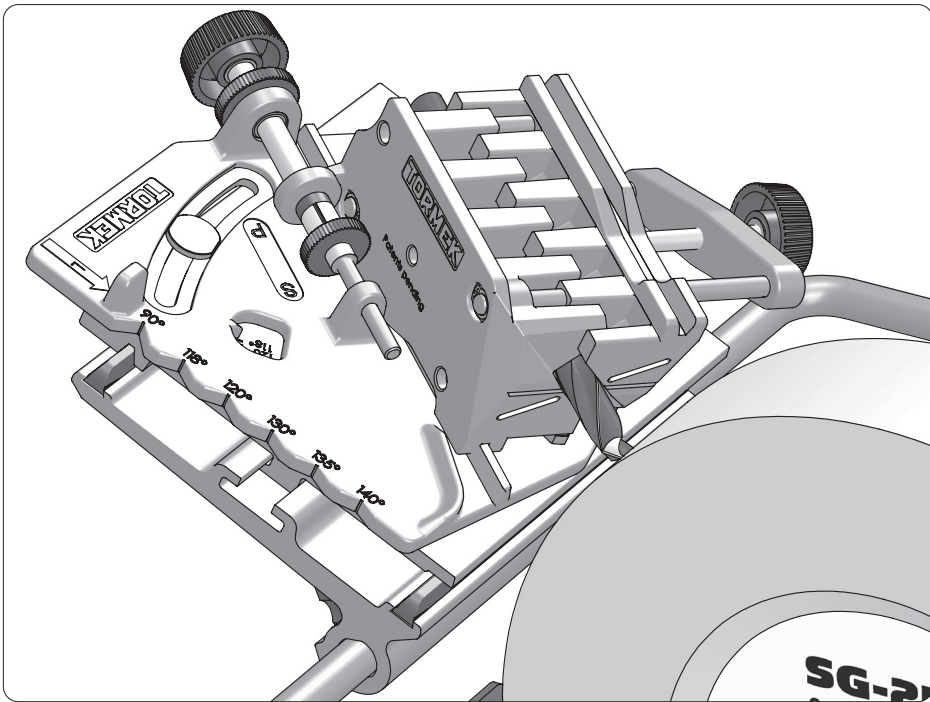

## Parts

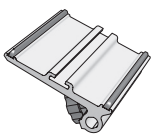

Base Plate

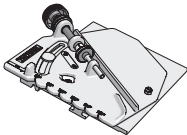

Guide

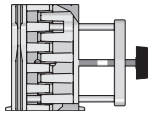

Drill Holder



Setting  
Template



Magnifier



Instruction

## Drill Bit Sharpening Attachment

With the patented Tormek Drill Bit Sharpening Attachment DBS-22, you can sharpen your drill bits with the highest accuracy. It copes with drills from 3 mm ( $\frac{1}{8}$ " ) to 22 mm ( $\frac{7}{8}$ " ) and with point angles from 90° to 150°. The optimal clearance angle can be set to 7°, 9°, 11° or 14° according to the drill size and type of material to be drilled. Water cooling eliminates overheating and micro cracks and at the low RPM you have full control over the grinding operation. No dust or sparks are produced.

The drill is ground with a *4-facet point*, which gives very good cutting performance. The chisel edge gets a point instead of being almost flat as on many drills. A 4-facet point will not walk and the thrust force required is considerably reduced compared to a conventional cone point drill. It generates less heat and the life of the drill is therefore prolonged. The 4-facet geometry causes the drill to bore a straighter and rounder hole with closer tolerances.

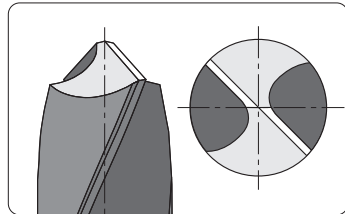

All the components are made with high precision which ensures that the lengths of the two cutting edges will be equal within close tolerances. This is an essential requirement so that the two edges will work in the same way and so that the drill will bore a round, straight hole, which is not larger than the drill diameter.

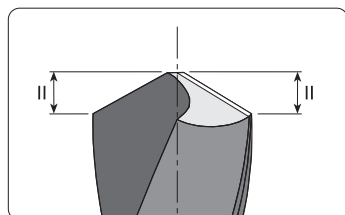

## Grinding, Shaping and Sharpening

The word *sharpening* is usually used for the final finishing of edge tools. Like all edge tools, a drill bit needs to have the right *shape* before you can start to sharpen it. Creating the initial shape often means that quite a lot of steel needs to be removed when for example, you change the point angle of a drill or you shape a broken or heavily worn drill. Once the geometry of the point is established, you maintain the sharpness by sharpening. With the Tormek system you can exactly replicate an existing shape and therefore you just need to touch up the edges.

The word *grinding* usually stands for both *shaping* and *sharpening*. In some operations, these slide into each other. With the Tormek System you can both shape and sharpen your drill bits. Throughout this manual we use the word grinding, which can mean both shaping and sharpening depending upon how much steel needs to be removed.

## Drill Point Geometry

Drill bits usually have a point angle of 118° or 130°. There are also 120°, 135°, 140° and 150° point angles. Hard steel and stainless steel require larger point angles. Also long-chipping material, such as copper and aluminium is best drilled with a larger point angle. When drilling plexiglass, the risk of cracks when the drill goes through the material is reduced with a smaller point angle, about 90°. Centering drills usually have a 90° point angle.

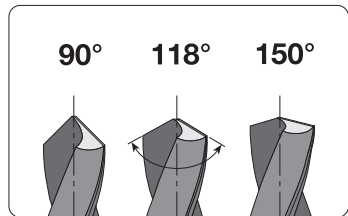

A drill bit needs to have the right lip clearance angle to cut the material. The clearance angle varies from 7° to 14°. A drill with a larger clearance angle cuts more easily, but if the angle is too large, vibrations will occur and the drill will cut irregularly and quickly become dull. If the clearance angle is too small, the drill will not cut at all, but will become hot and rapidly destroyed.

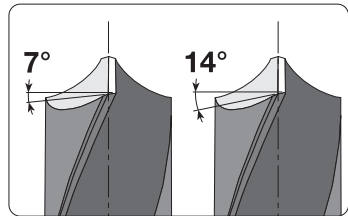

The optimal clearance angle for the job depends on the material – a harder material requires a drill with a smaller clearance angle while a softer material can have a larger angle. The size of the drill is also a determinant for the selection of the optimal clearance angle. A larger drill should have a smaller clearance angle while a smaller should have a larger one.

Many new drill bits are ground with a basic cone point. The two cutting lips meet in the centre and form a chisel edge, **C**. This point geometry is not ideal, since the chisel edge needs to be pressed into the material without cutting. The friction of the chisel edge creates much heat, which decreases the life of the drill bit. Since the chisel edge has no tip, the drill walks when drilling a new hole, which is not pre-drilled.

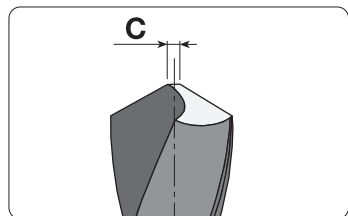

More expensive drill bits are ground with special points of various types. These drills must be re-sharpened in their original production machines or in special machines, which are available only at a few specialist sharpening shops. They can also be re-shaped to a 4-facet point with the Tormek attachment.

## This is How the Attachment Works

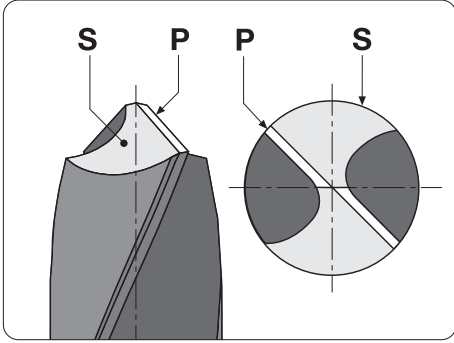

The drill is ground to a 4-facet point. **The Primary facets, P** and the **Secondary facets, S** meet in the centre and form a point.

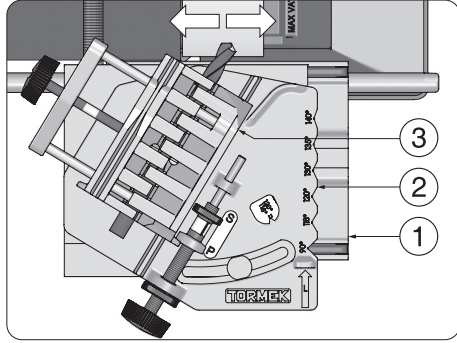

The drill is mounted in a Drill Holder (3) on a Guide (2), which in turn runs on a Base (1). You move the drill across the grindstone – the grinding automatically takes place on the highest spot of the stone.

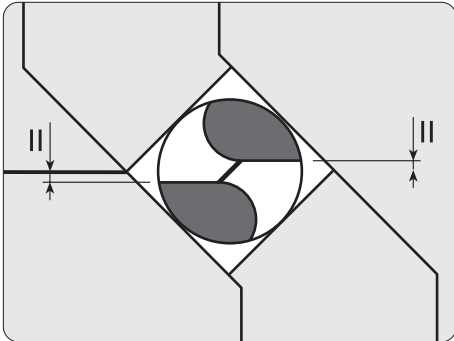

The high precision drill holder consists of two identical parts. The drill will be exactly centered and both of the cutting edges will be sharpened exactly to the same shape.

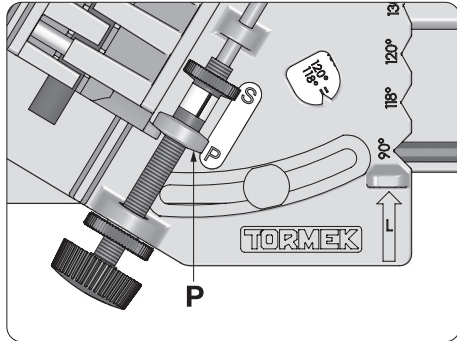

The grinding depth for the first two facets is determined by adjusting a setting screw which has a stop, **P**. These initial facets are called primary facets.

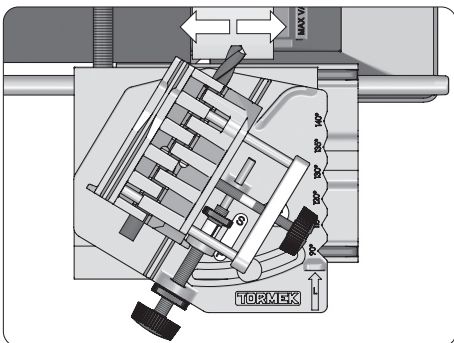

After grinding one facet, the drill holder is turned 180° and the other facet is ground to an identical shape. Now both of the two primary facets are ground.

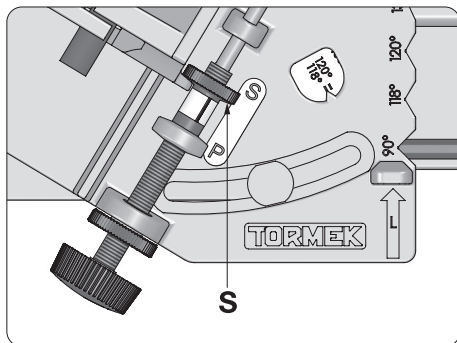

After grinding the primary facets, the drill holder is moved forward to a second stop **S** for grinding the secondary facets, which gives the drill a 4-facet point.

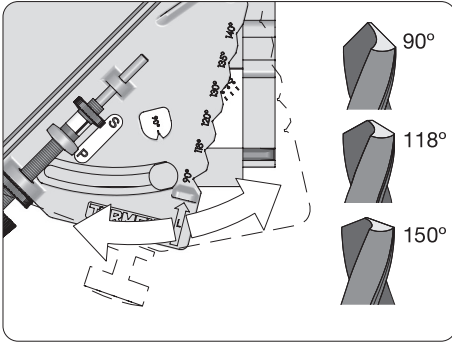

The point angle can be set at any angle by turning the guide. The jig copes with all point angles from 90° to 150°.

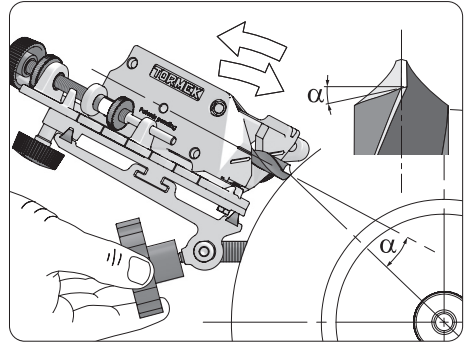

The clearance angle ( $\alpha$ ) is set by tilting the base. It can be set at 7°, 9°, 11° or 14°.

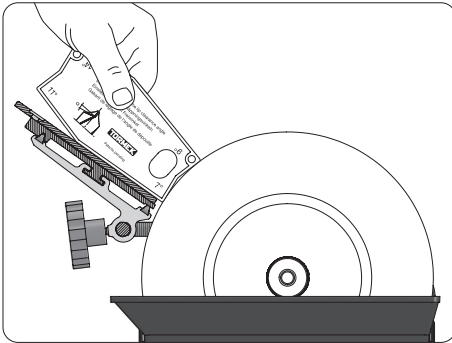

With the Setting Template you set the selected lip clearance angle. The picture shows 7°. The Setting Template works on any grindstone diameter.

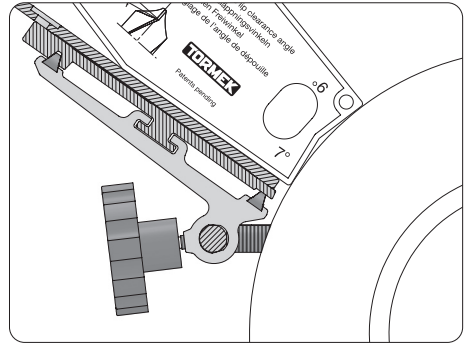

## Mount the Grinding Attachment

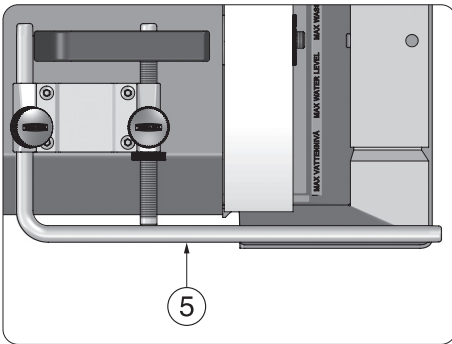

Mount the Universal Support horizontally (5).

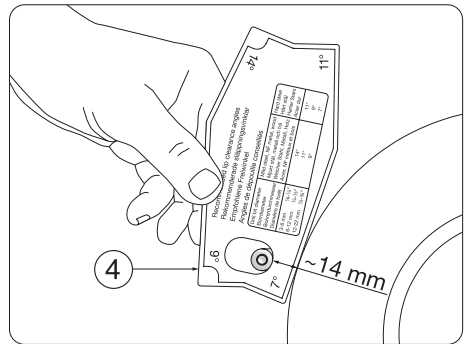

Lock it on a distance of approx. 14 mm ( $\frac{9}{16}$ " ) from the stone. The template gives you the right distance.

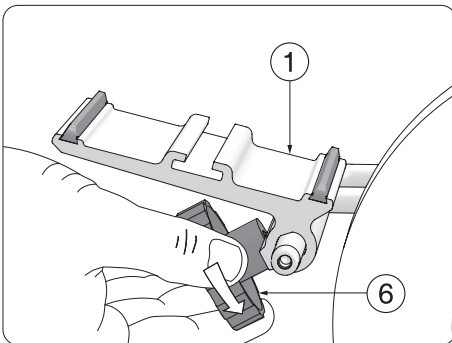

Slide the Base Plate (1) onto the Universal Support and lock it temporarily with the wheel (6).

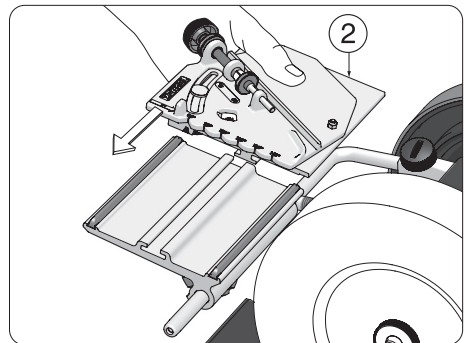

Slide the Guiding Plate (2) into the base plate.

## Mount the Drill Bit

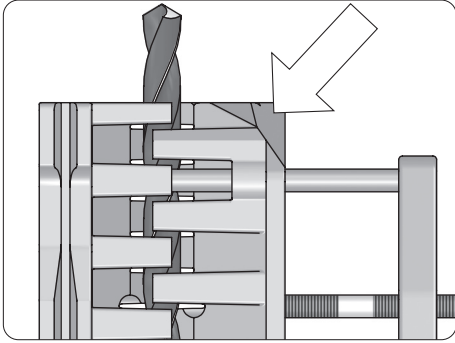

Turn the drill holder so the bevelled side points towards the machine.

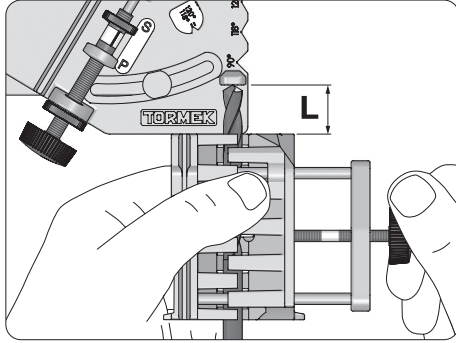

Mount the drill with the protrusion **L** indicated by the stop on the Guide. Lock the drill temporarily.

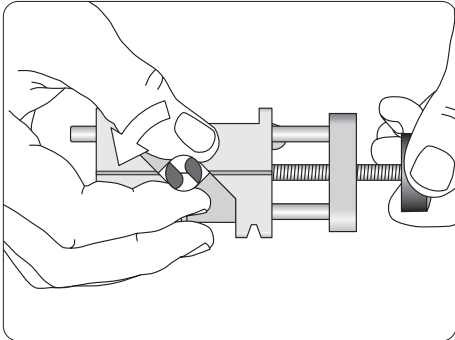

Loosen the wheel and rotate the drill so that the cutting edges are aligned parallel to the horizontal lines on the Drill Holder. Tighten the wheel. The protrusion **L** does not need to remain exact.

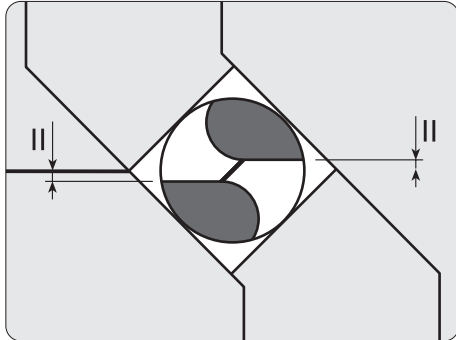

**Note!** Here it is shown how to mount and grind a slightly blunt drill. Heavily worn and broken drills need a different setting in the Drill Holder. This is because the direction of the cutting edges changes gradually during the grinding. See page 13.

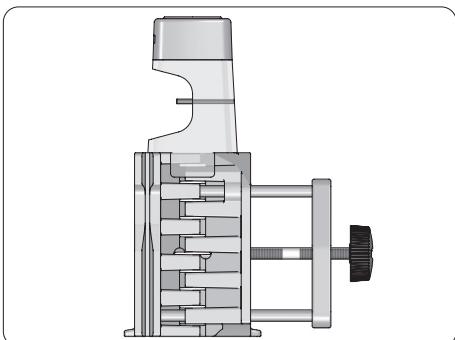

For small drills, up to approx. 8 mm ( $\frac{5}{16}$ " ) you can use the special Tormek Magnifier.

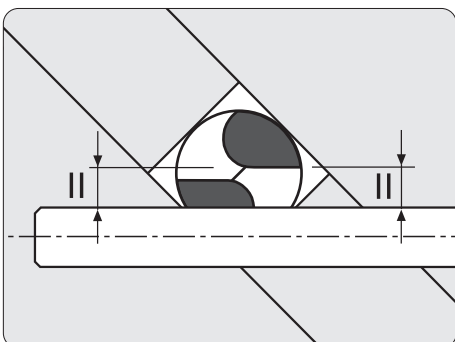
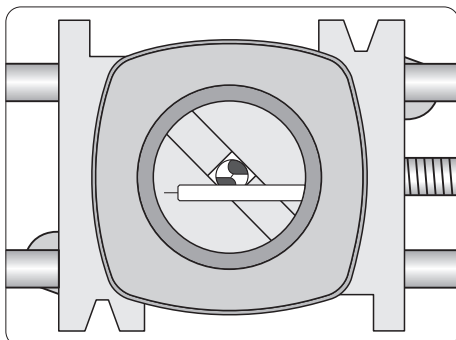

The cutting edges should be parallel to the pin in the Magnifier.

# Set the Clearance Angle and the Point Angle

## A. Standard Drills

Standard drills have a clearance angle of 11° and a 118° point angle. These work well for most drilling work.

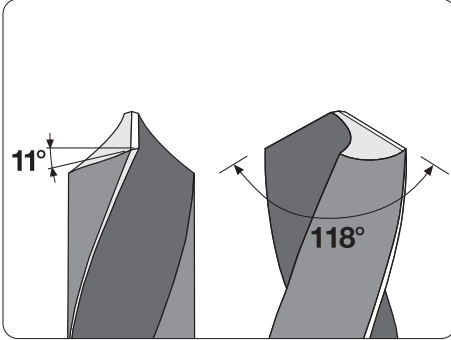

Clearance angle 11°. Point angle 118°.

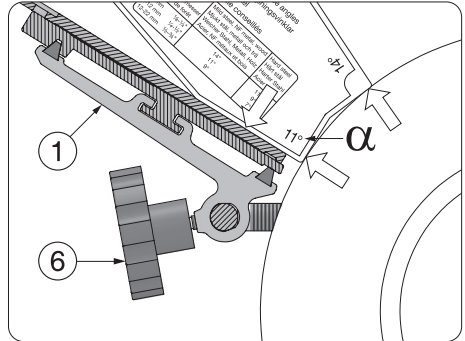

**The clearance angle.** Place the Setting Template according to the image and tilt the base (1) so that the corners of the Setting Template touch the grindstone. Lock it securely with the wheel (6).

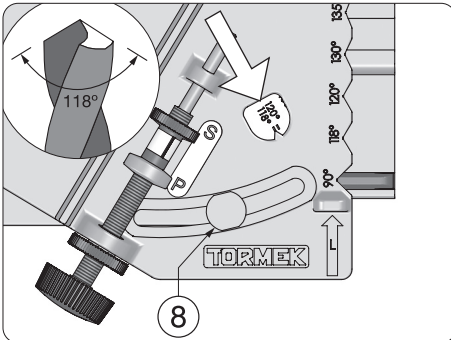

**The point angle.** Set the point angle at 118°. Lock securely with the wheel (8).

## B. Drills for Optimal Function

With the Tormek Drill Bit Attachment you can grind your drill so it works in the optimal way for each drilling task. This is especially beneficial for series production, where the selection of the point angle and clearance angle are determining factors for the life of the drill. The choice of clearance angle depends on the material to be drilled and the size of the drill.

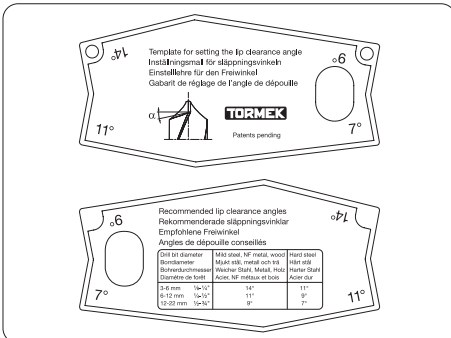

Recommended lip clearance angles  
Rekommenderade släppningsvinklar  
Empfohlene Freiwinkel  
Angles de dépouille conseillés

Drill bit diameter Borrdiameter Bohrer Diamètre de forêt	Mild steel, NF metal, wood Mjukt stål, metall och trä Weicher Stahl, Metall, Holz Acier, NF métaux et bois	Hard steel Hårt stål Harter Stahl Acier dur
3-6 mm 1/8-1/4"	14°	11°
6-12 mm 1/4-1/2"	11°	9°
12-22 mm 1/2-3/4"	9°	7°

**Clearance angle.** With the Tormek Setting Template you can set the clearance angle to 7°, 9°, 11° or 14°. The Template recommends a suitable angle based upon the drill size and the material to be drilled.

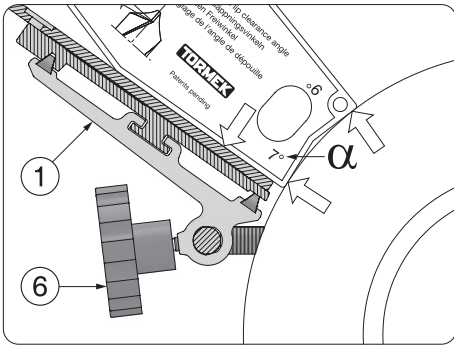

**The clearance angle,  $\alpha$ .** Here 7°. Tilt the Base (1) so that both corners of the Setting Template touch the grindstone. Lock it securely with the wheel (6).

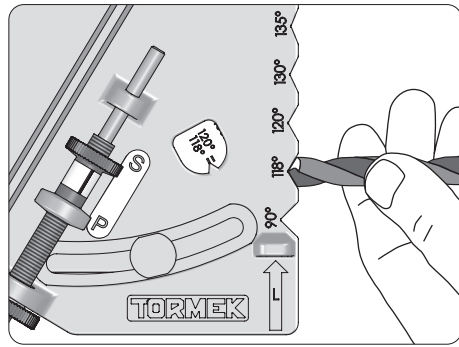

**The point angle.** Measure the existing point angle in the grooves on the Guide or select the angle which is most suitable for the job.

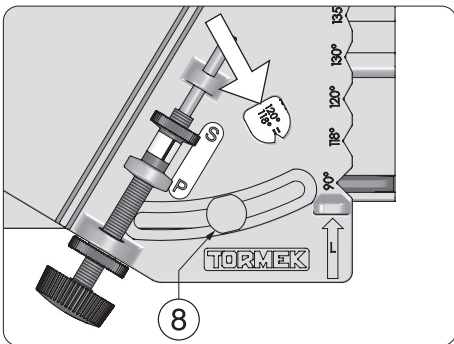

Set the guide on the selected point angle and lock with the wheel (8).

## Grind the Primary Facets

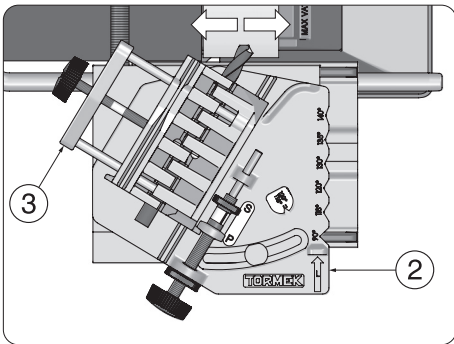

Place the Drill Holder (3) on the guide (2) so that the lug (11) touches the stop P.

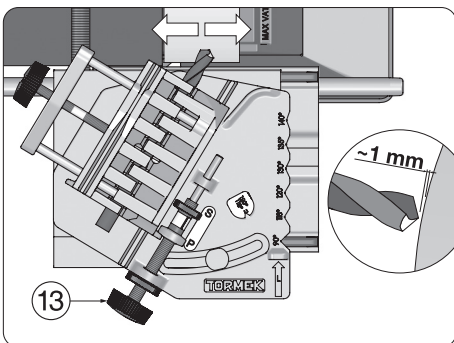
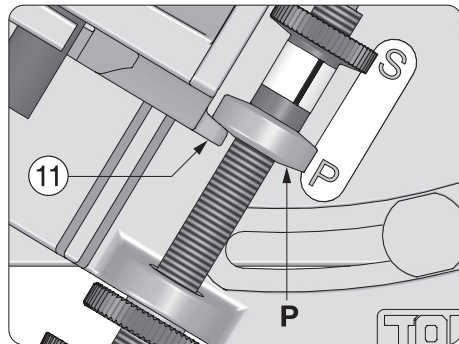

Adjust the setting screw (13) so that the drill is approx. 1 mm (0.04") from the grindstone. Start the machine.

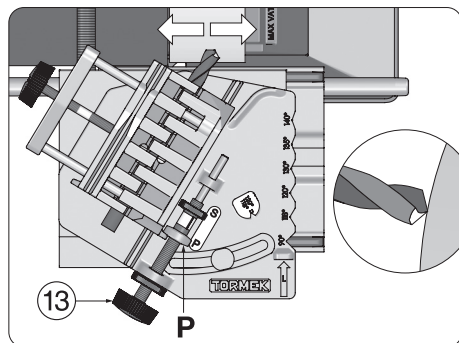

Set the cutting depth to zero by adjusting the stop P towards the grindstone until you hear the drill lightly touching the grindstone. Stop the machine.



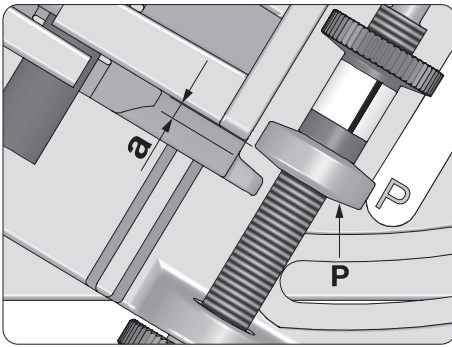

Screw the stop **P** further downwards (**a**) by as much as the tip should be ground. One turn is equal to 0.5 mm (0.02") cutting depth.

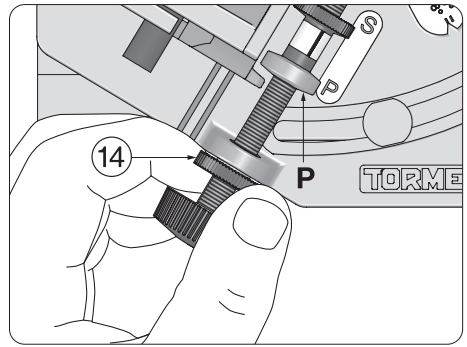

Lock the stop **P** with the locking nut (14). Start the machine.

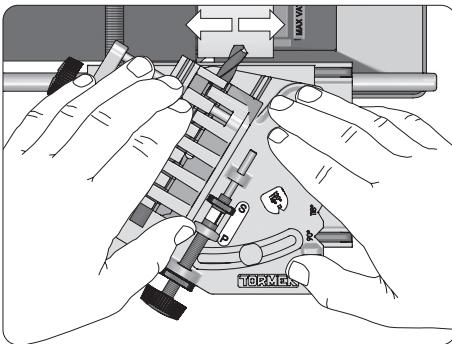

Press the drill holder towards the grindstone and grind one of the primary facets. Move the guide back and forth across the grindstone.

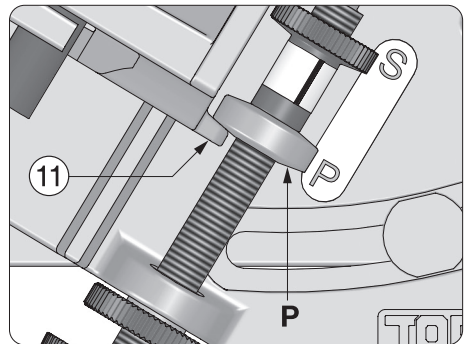

Grind until the lug (11) touches the stop **P**.

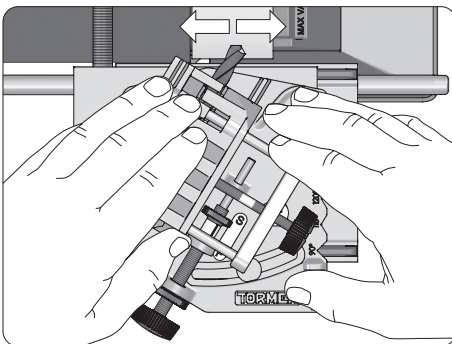

Lift and turn the drill holder 180° and grind the other primary facet in the same way.

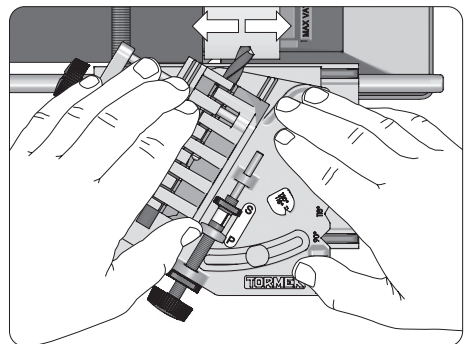

Grind alternately both the primary facets until they reach over the centre of the drill.

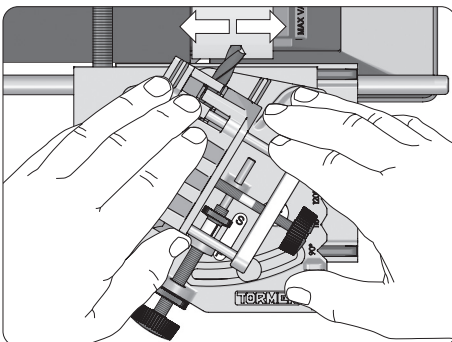

You can tell by the decreasing sound when the primary facets **P** are ground equally. How far they are ground over the centre does not matter. It is important that they are ground symmetrically. The primary facets should meet and form a flat chisel edge, **C**.

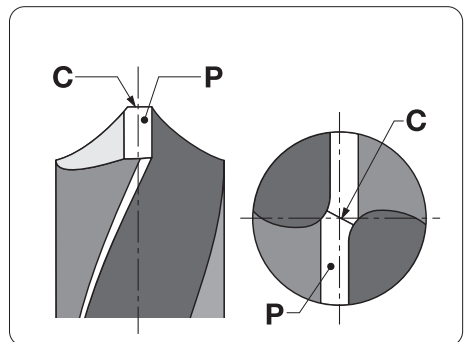

## Grind the Secondary Facets and Create a 4-Facet Point

The two primary facets meet and form a horizontal and flat chisel edge without a tip. This chisel edge is not the best since the drill will walk when you start drilling. The chisel edge will also take a great deal of the axial force without actually cutting and therefore creates much heat.

By grinding two secondary facets, the drill gets a 4-facet shape and a tip, which is beneficial for the function. The thrust force required is reduced as well as the heat development which is most detrimental to the life of the drill bit. Furthermore a 4-facet point drills a straighter hole and will not walk.

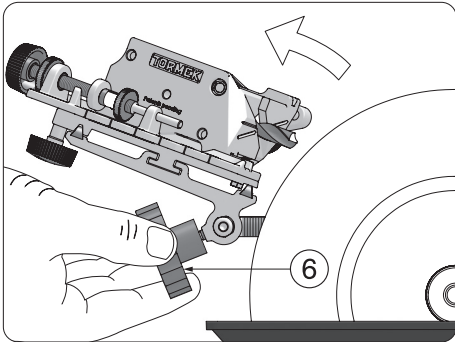

Loosen the wheel (6) and tilt the base to an approx. horizontal position.

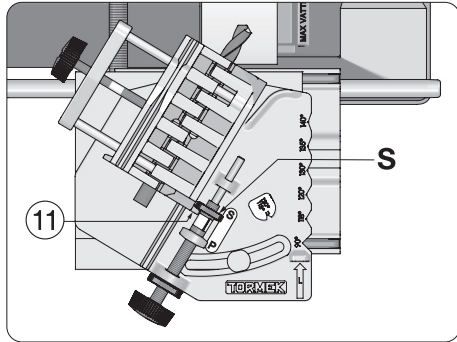

Lift and move the drill holder forwards so that the lug (11) rests on the stop nut S.

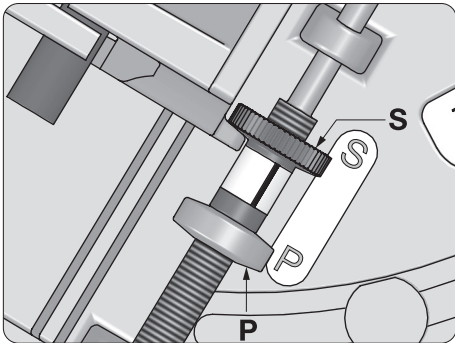

The stop nut S must be screwed to touch the stop P.

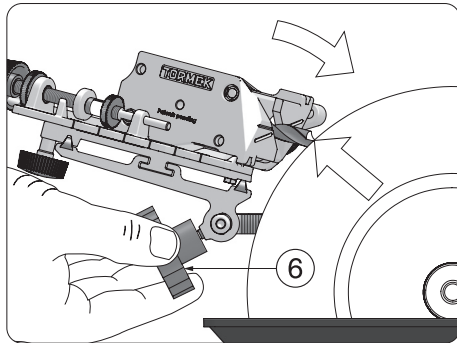

Tilt the base until the heel of the drill touches the grindstone and lock it with the wheel (6).

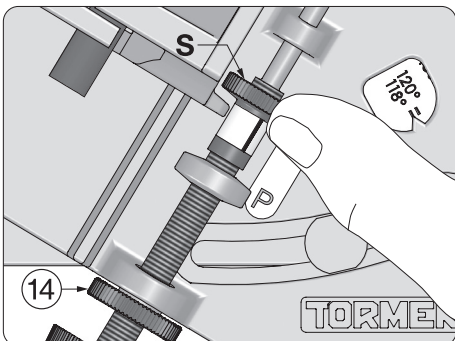

Screw the stop nut S forwards. Start with 1½ turn for a 6 mm (¼") drill. The setting screw should still be locked with the locking nut (14).

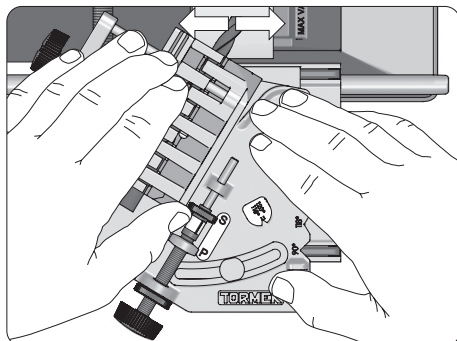

Start the machine. Press the drill holder towards the grindstone and start grinding the first secondary facet. Move the guide back and forth across the stone.

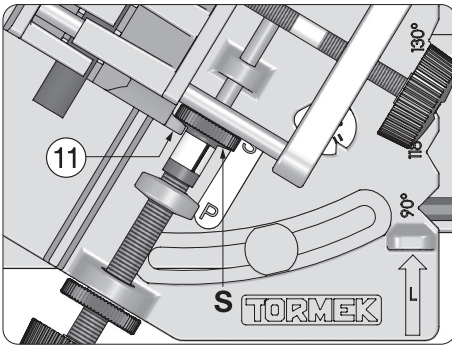

Continue grinding until the lug (11) touches the stop nut S.

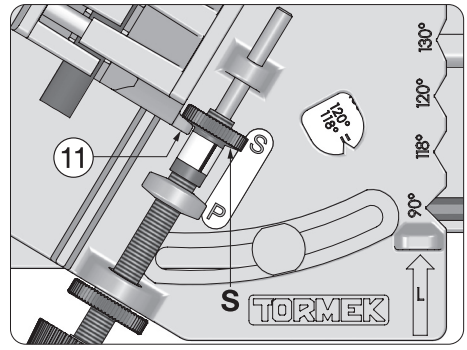

Turn the drill holder 180° and grind the other secondary facet in the same way.

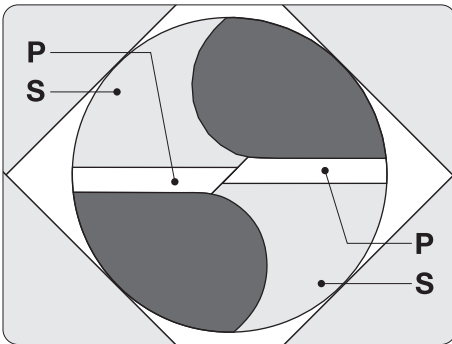

Now the 4-facet shape will start to develop, but the secondary facets S need to be ground further so that they meet in the centre and form a point.

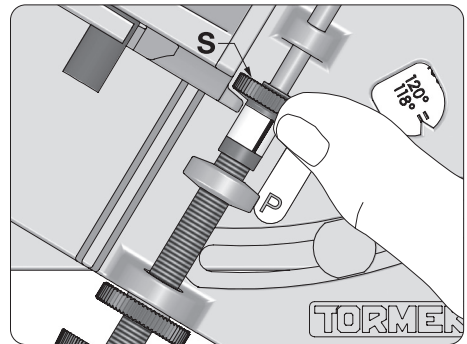

Feed the nut S a bit further. Try with 1/4 of a turn. One turn is equal to 0.5 mm (0.02").

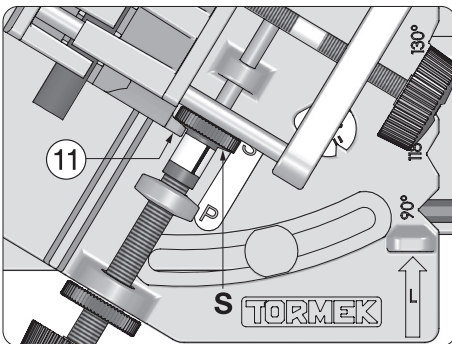

Grind the two secondary bevels alternately until the lug (11) touches the stop nut S on both sides. Make the final grindings carefully and check that the facets are symmetrical and form a point.

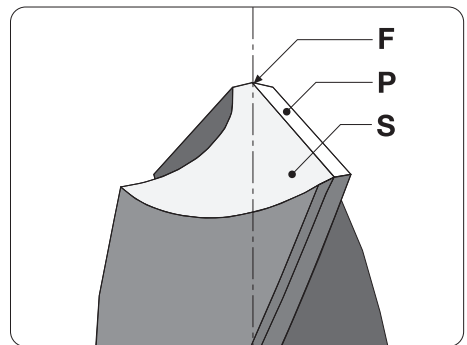
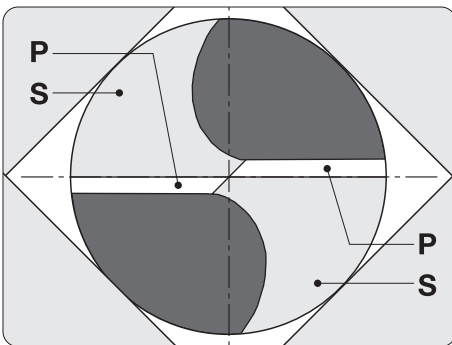
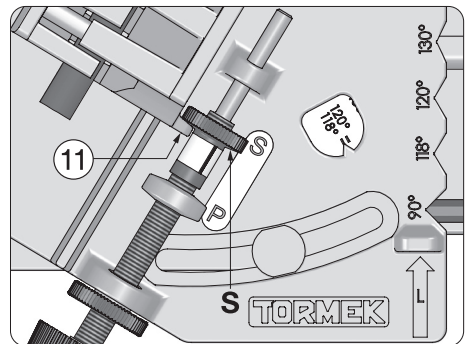

This is how a ground drill should look like. The secondary facets S meet the primary facets P in the centre. The flat chisel edge has been shaped to a point, F.

## Some Advice and Tips

### Heavily Worn Drills

If the drill is heavily worn, quite a lot of material needs to be ground away to obtain new cutting edges. In this case you need to mount the drill turned anticlockwise towards the slanting lines. How much depends upon the degree of wear. As the drill is ground the cutting edges change direction. When the grinding is completed, the edges should be parallel to the horizontal lines.

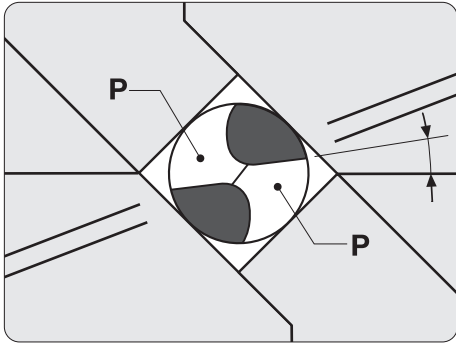

Mount a heavily worn drill turned anticlockwise.

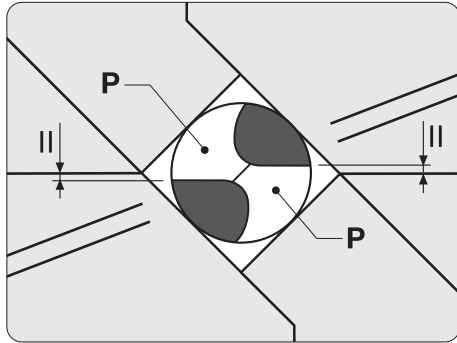

When the grinding is finished the primary facets **P** should be parallel to the horizontal lines.

### Broken Drills

When mounting these are turned anticlockwise so that the edges **E** are parallel to the slanting lines. The primary facets are developing during the grinding and when the grinding is finished they should be parallel to the horizontal lines.

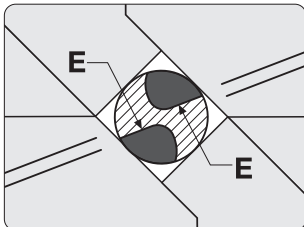

Mount the drill so that the edges **E** are parallel to the slanting lines.

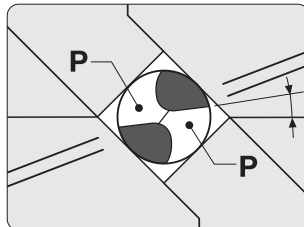

After a few minutes the primary facets **P** are ground. It takes approx. 4 minutes for a 10 mm ( $\frac{3}{8}$ " drill).

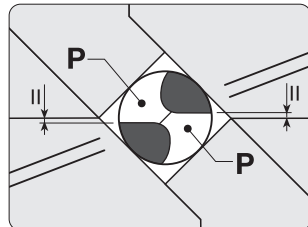

Continue grinding until the primary facets **P** are parallel to the horizontal lines.

### Thicker Drills

When grinding thicker drills (over approx. 10 mm or  $\frac{3}{8}$ " for the first time, quite a lot of material needs to be ground away to achieve the right secondary bevels. If you start by grinding away the heel on a bench grinder, you can save time. The heel has no influence on the function of the drill.

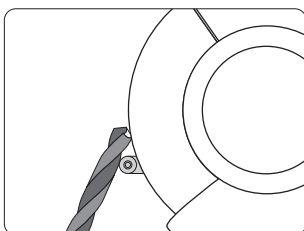

Grind away the heel on a bench grinder.

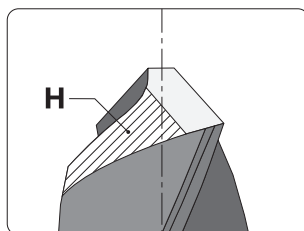

The heel **H**, is ground away.

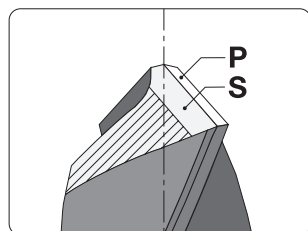

Finished ground drill on the Tormek machine.

## Deviations from the Ideal Point Geometry

The drill bit does not necessarily need to be mounted with the edges exactly parallel to the horizontal lines. These two examples show the result if the drill is a bit misaligned. The drill still works, but you should strive to get the edges parallel to maximize the life of the drill. It is preferable if the primary facets are wider towards the periphery than thinner.

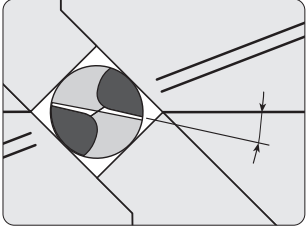

*Drill mounted clockwise. Thinner primary facets at the periphery.*

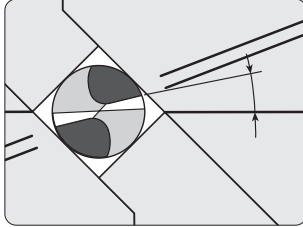

*Drill mounted anticlockwise. Wider primary facets at the periphery.*

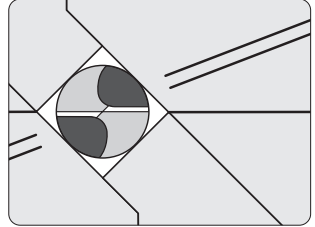

*Drill mounted correctly. The width of the primary facets are even.*

## Replication of the Primary Facets

If you have ground the secondary facets too much, then go back and grind carefully on the primary facets again.

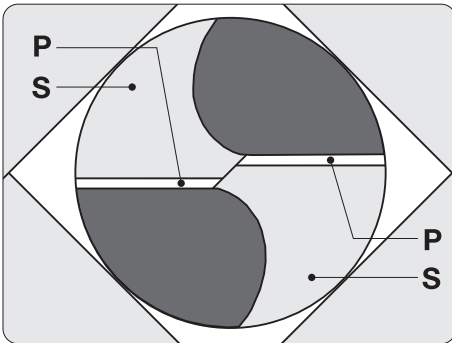

*The secondary facets **S** have been ground too much leaving primary facets too small.*

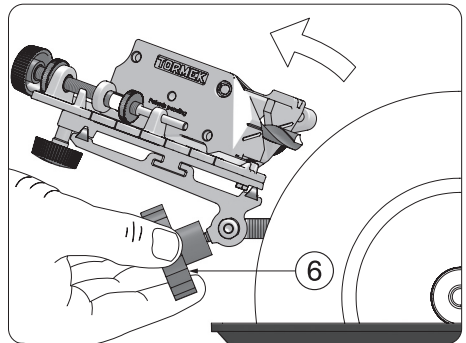

*Loosen the wheel (6) and tilt the base to an approx. horizontal position.*

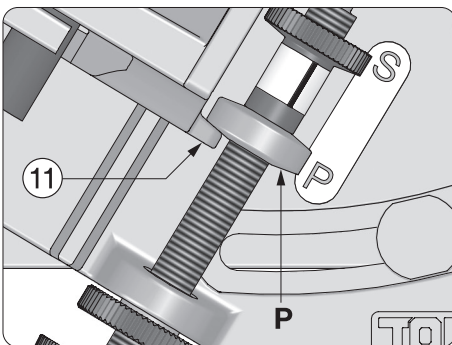

*Lift and move the drill holder so the lug (11) touches the stop **P**.*

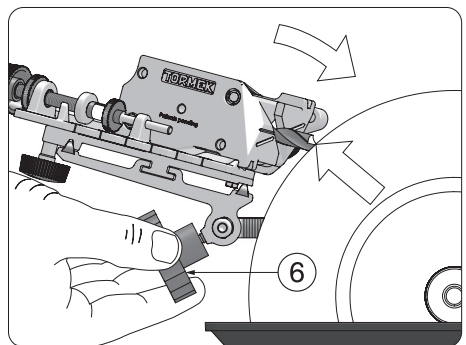

*Tilt the base until the primary facet touches the grindstone. Lock it securely.*

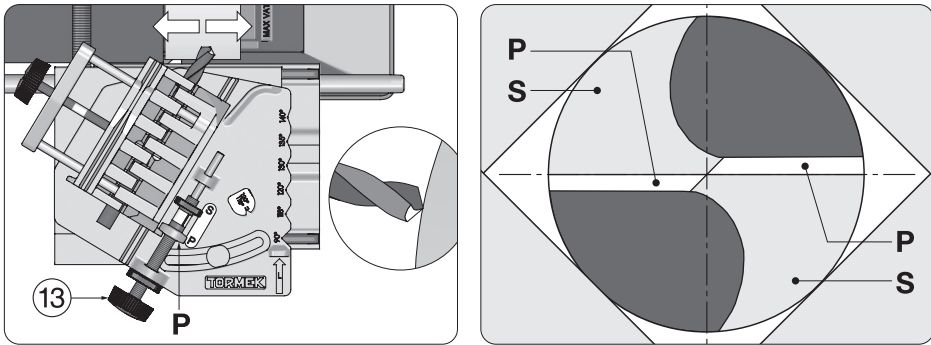

Turn the setting screw (13) lightly towards the grindstone and grind carefully until the 4-facet point is established again.

## Reaming an Existing Hole

If you need to make an existing hole larger, you do not need to grind the secondary facets. However the existing hole  $\varnothing D$  must be larger than the chisel edge, **C**.

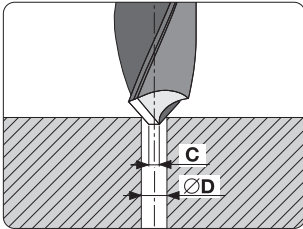

## Re-Sharpen Before the Drill Stops Working

Do not allow the drill to be worn so much that it starts to perform badly. Instead, grind as soon as you notice that it does not work as it should, otherwise you need to re-shape the point instead of just touching it up.

## Keeping the Grindstone Active

If the efficiency of the grindstone decreases during sharpening, you can easily re-active it by using the coarse side of the Tormek Stone Grader SP-650. It brings new grinding grains into operation and increases the efficiency of the stone. The Stone Grader can be especially useful when grinding thicker drills which have a large grinding area.

## Finer Surface

The Original Tormek Grindstone is 220 grit and gives a smooth cutting edge, finer than from conventional high speed grinding. After you have ground the drill bit to the right shape, you can use the fine side of the Tormek Stone Grader SP-650 to grade the stone so that it corresponds to 1000 grit. Then you can further refine the primary facets. The finer the surface of the edge – the better it will cut and the longer it lasts.

When grinding smaller drills (up to approx. 6 mm or ¼") it is recommended that you refine the grindstone from the beginning, since the stone otherwise can cut too aggressively on a small drill.

## Honing on the Leather Honing Wheels

You can further improve the cutting performance by using the Leather Honing Wheels. By honing away the burr which has developed during grinding, you also polish the edges and increase the durability of the drill bit.

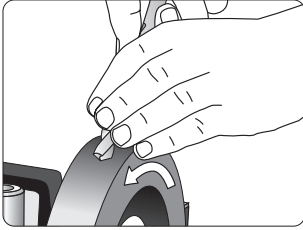

*The facets are honed on the standard flat honing wheel.*

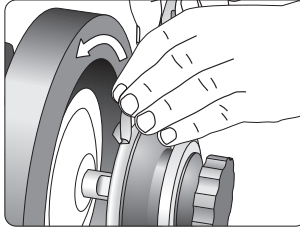

*The flute is honed on one of the profiled leather honing wheels. Select the wheel according to the size of drill.*

